



 **kwvb**[®]
WE LOVE PERFECTION.

POWER TOOL ACCESSORIES

GENERAL CATALOGUE

The new kwb Power Tool Accessories catalogue

Dear customers,
Welcome to our new kwb Power Tool Accessories catalogue.

For more than 80 years, kwb tools GmbH has been the system provider for power tool accessories and hand tools.

A good, strong brand is characterised by experience, high inventory availability, reliable quality and innovative thinking! This is what kwb tools GmbH stands for. It is our goal to purchase kwb items at the highest quality level from all over the world. kwb tools GmbH proves this day in day out, with passion and dedication to you, our partners.

We have modernised the layout of the new kwb Power Tool Accessories catalogue and designed it to provide more detailed and transparent information.

Let us inspire you with our new kwb Power Tool Accessory catalogue, and discover the variety of the updated kwb range of accessories.

This new kwb Power Tool Accessory catalogue includes many new products to round off the range of power tool accessories.

True to our slogan “...always the right accessories for your machine!”, kwb offers its clients, and the end customer plenty of accessories that he requires for his power tool.



kwb tools Managing Director Gerrit Brand, Alexander Uhl

Product	Item	Page
Drills	COBALT HSS CO twist drills	10 - 13
	Titanium HSS twist drills	14 - 15
	Silver Star HSS twist drills	16 - 21
	HSS twist drills	22 - 27
	Drill grinding attachment	27
	Hammer drill bits SDS Max, SDS Plus	32, 35 - 38
	Chisels for rotary hammers SDS Max, SDS Plus	32 - 34, 39 - 40
	CROSS TIP hammer drill bits	41
	Concrete drills BOSCH UNEO	42
	Concrete and masonry drill bits ROCKER® / SUPER ROCKER®	42 - 45
	Masonry drills, extra long masonry drills	45 - 48
	EASY CUT multi-material hammer drills SDS Plus, EASY CUT multi-material drill bits	52 - 53
	Hard tile drill bits, glass drills, various TCT tools	54 - 56
	Hardwood drill bits	60
	Wood drill bits, beam drills, framework drills, auger bits hinge sinker bits, Forstner bits, flat wood bits, expanding wood bit	61 - 66 67 - 69
Screwdriver bits	Bit holders, Impaktor bits, Bits, Handy Bit Box, Screwdriving tools	74 - 98
Drill accessories	Chucks	102 - 103
	Chuck key	104
	Rasps, countersinks, conecut drills, rotary files	105 - 113
	Attachments, drill stands, flexible shafts	114
	Mounted grinding points	115 - 117
	Pumps	118 - 119
	Mixing paddles	120 - 121
Holesaws	Hollow core drills, holesaws	128 - 140
Brushes	Wire brushes, nylon brushes	144 - 150
Sanding	Abrasive rolls, sanding sheets	156 - 159
	Standard paper sanding discs, QUICK-STICK paper sanding discs	162 - 167
	Standard backing pads, QUICK-STICK backing pads	162, 163 + 167
	QUICK-STICK detail sander discs, scouring pads	170 - 174
	QUICK-STICK backing pads	174
	Standard orbital sander sheets, QUICK-STICK orbital sander sheets	180 - 182, 182 - 184
	Mesh sanding sheets	185
	Sanding belts	189 - 192
	Sanding sponges, steel wool	193 - 194, 195
	Hand sanders	196 - 197
	Flap discs	198
	Polishing bonnets, polishing wheels	199 - 201
Router cutters	Router cutters	206 - 210
Tungsten carbide planer blades	Tungsten carbide planer blades	211
Line Master	LINE MASTER, Power tool rail system	213 - 220
Jigsaw blades	Jigsaw blades	224 - 232
Reciprocating saw blades	Reciprocating saw blades	233 - 238
	MULTITOOL accessories	239 - 245
Circular saw blades	Circular saw blades	247 - 278
Chainsaw chains	Chainsaw chains	279 - 306
Nylons strimmer lines	Nylons strimmer lines	309
Tackers	Electronic tackers TACKERTRONIX®, hammer tackers	314
Hot melt glue guns	Hand tackers, fastenings	315 - 325
	Hot melt glue guns	326 - 327
Fixings	Dowels, dowel accessories, dowel drilling guide	332 - 335
Cutting discs Wire brushes	Cutting- and grinding discs, flap discs	340 - 342
	Polycarbide cleaning discs, fibre-backed discs, angle grinder backing pads	342 - 344
	Diamond cutting discs, face grinding discs, ceramic grinding wheels	345 - 347
	Wire brushes	348 - 349
	Pin spanners, angle grinder cut-off stand	350 - 351

Catalogue summary



Tight corner end brush, HSS steel wire



Tight corner end brush, HSS steel wire, crimped, for derusting, cleaning, removing surface coatings, paint and rubber residue, descaling, deburring, roughing up and matt finishing, for metal and stone, ideal for working in inaccessible areas and inner surfaces, eg wrought iron gates, grilles and gratings etc.



Art.-Nr.	Ø mm	T mm	Draht Ø mm				EAN
----------	------	------	------------	--	--	--	-----

SB-Karte 9							
-------------------	--	--	--	--	--	--	--

608030	25	6	0,30	grob		6	4 009316 080306
--------	----	---	------	------	--	---	-----------------

lose Depotkarton							
------------------	--	--	--	--	--	--	--

608033	25	6	0,30	grob		Z24	4 009316 080337
--------	----	---	------	------	--	-----	-----------------

1 Product heading

2 Quality information

see description on page 5

3 Illustration

Packaging/ options/ applications

4 Detailed product information

5 kwb part number

is also the stock number for the product

6 Technical date and user advice

7 Symbol = item display packed

Eg carded, walleted or in display box with or without hanger

Actual example for the symbol above:

Symbol present eg. with 608030 = carded

Symbol not present eg. with 608033 = article sold loose

8 Symbol = box quantity

9 Type of packaging

kwb qualities

kwb stands for quality.

With the triple-graded quality system from kwb, you can always find the right tool for your particular needs and levels of use.



PROFESSIONAL



The best kwb quality, also suitable for long-term professional use. 5 year guarantee.



HIGH QUALITY



The high grade kwb quality, suitable for professional DIYers.



QUALITY



The everyday good quality from kwb, for DIY use.

... always the appropriate accessories for your machine!





DRILL BITS FOR METAL

COBALT HSS-CO Drills

Titanium HSS Drills

SILVER STAR HSS Drills

HSS Twist Drills

Drill bits for metal



The benefits of ground flute drill bits COBALT HSS-CO, Titanium HSS and SILVER STAR HSS

- long working life due to accurately ground spirals
- exact hole diameters to very close tolerances
- cross-ground drill bits facilitate centering without punching or pilot drilling
- high quality surface hardening gives long working life even under extreme conditions

Programme overview HSS High speed steel twist drills for metal



COBALT HSS-CO Drills, DIN 338

★★★★★

5% cobalt alloyed steel construction gives high heat resistance and hard-wearing performance even in the hardest materials such as stainless steel.



Page 10 - 13



Titanium HSS Drills, DIN 338

★★★★★

High quality surface hardening gives long working life even under extreme conditions.

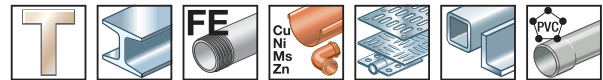

Page 14 - 15



SILVER STAR HSS Drills, DIN 338

★★★★★

Up to 40% quicker or 50% less pressure required.

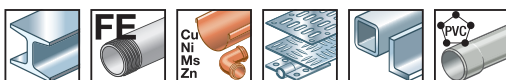

Page 16 - 21



HSS Twist Drills, long series, DIN 340

★★★★★

Up to 40% quicker or 50% less pressure required. The long series HSS twist drills are especially suitable for use deepening holes, or in grooves, recesses, channels, hollow sections, profiles etc.



Page 23

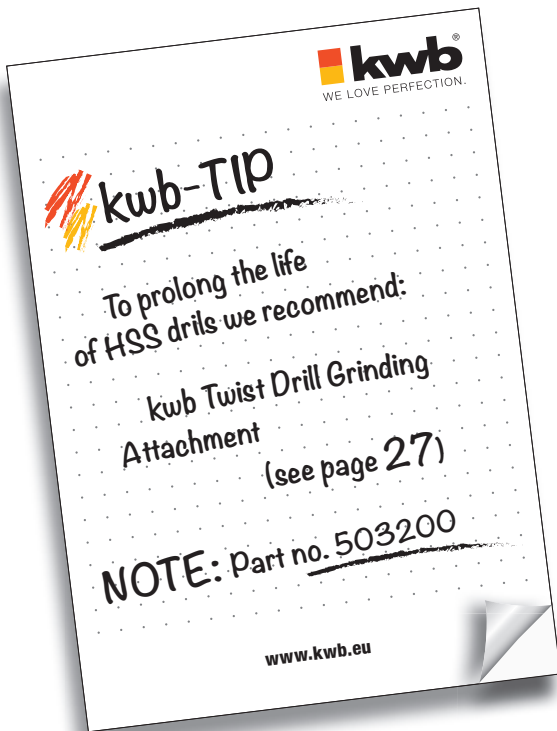

kwb-Info

Colour-coding system for the metal drill bit packaging

On the drill bit packaging, KWB sets out well-targeted end user information. The packaging attracts attention with a clear colour-coding system to indicate the correct drill for the relevant material with informative action photos.

- COBALT
- TITANIUM
- SILVER STAR
- HSS Twist Drills



HSS Twist Drills roll forged, DIN 338 ★★★

Roll forged, a competitively priced HSS drill for all applications in steel, cast iron, non-ferrous metals and plastics.



Page 23 - 26



HSS Twist Drills, reduced shank, DIN 338 ★★★

The reduced shank makes it easy to use large diameters in all commonly used electric drills. Suitable for chucks with 10 and 13mm capacity.

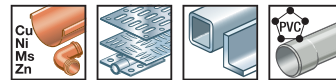

Page 27

Recommended drilling speeds for HSS drills

Revolutions per minute	Titanium	Stainless steel	Steel	Iron	Non-ferrous metals	Sheet steel	Profiles	Plastics
≤ Ø 2 mm	1590	1590	3980	4780	7170	3980	12740	3980
Ø 2,1 - 4 mm	800	800	1990	2390	3580	1990	6370	1990
Ø 4,1 - 6 mm	530	530	1330	1590	2390	1330	4250	1330
Ø 6,1 - 8 mm	400	400	1000	1190	1790	1000	3180	1000
Ø 8,1 - 10 mm	320	320	800	960	1430	800	2550	800
Ø 10,1 - 12 mm	270	270	660	800	1190	660	2120	660
Ø 12,1 - 13 mm	230	230	570	680	1020	570	1820	570

... always the appropriate accessories for your machine!

COBALT HSS CO twist drills, DIN 338, carded



Right hand cut, type N, 5% Cobalt alloyed, precision ground, bronze colour. Tip angle 135 deg., cross-ground to DIN 1412 C, self centering, cylindrical, industrial quality, extreme heat resistance for difficult-to-work materials e.g. Steel and alloyed steel, stainless steel grades A2/ A4, cast iron and cast steel, bronze, plastics.

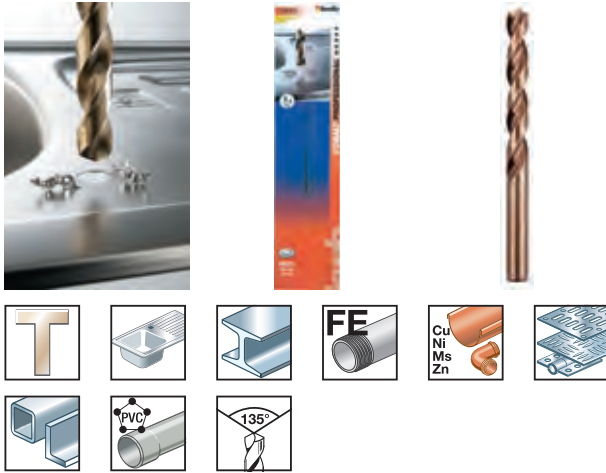































Art.-No.	Ø mm	Tapping hole for thread size			Barcode
carded					
248610	1			10	4 0093 12 486 102
248615	1,5			10	4 0093 12 486 157
248620	2			10	4 0093 12 486 201
248625	2,5	M 3		10	4 0093 12 486 256
248630	3			10	4 0093 12 486 300
248633	3,3	M 4		10	4 0093 12 486 331
248635	3,5			10	4 0093 12 486 355
248640	4			5	4 0093 12 486 409
248642	4,2	M 5		5	4 0093 12 486 423
248645	4,5			5	4 0093 12 486 454
248650	5	M 6		5	4 0093 12 486 508
248655	5,5			5	4 0093 12 486 553
248660	6	M 7		5	4 0093 12 486 607
248665	6,5			5	4 0093 12 486 652
248668	6,8	M 8		5	4 0093 12 486 683
248670	7			3	4 0093 12 486 706
248675	7,5			3	4 0093 12 486 751
248680	8			3	4 0093 12 486 805
248685	8,5	M10		3	4 0093 12 486 850
248690	9			3	4 0093 12 486 904
248695	9,5	M 11		3	4 0093 12 486 959
248700	10			3	4 0093 12 487 000
248710	11			2	4 0093 12 487 109
248720	12			2	4 0093 12 487 208
248730	13			2	4 0093 12 487 307

Drill bits for metal

COBALT HSS CO twist drills, DIN 388, bulk



Art.-No.	Ø mm	Tapping hole for thread size			Barcode
Bulk, in tube					
248010	1			Z10	
248015	1,5			Z10	
248020	2			Z10	
248025	2,5	M 3		Z10	
248030	3			Z10	
248033	3,3	M 4		Z10	
248035	3,5			Z10	
248040	4			Z5	
248042	4,2	M 5		Z5	
248045	4,5			Z5	
248050	5	M 6		Z5	
248055	5,5			Z5	
248060	6	M 7		Z5	
248065	6,5			Z5	
248068	6,8	M 8		Z5	
248070	7			Z3	
248075	7,5			Z3	
248080	8			Z3	
248085	8,5	M10		Z3	
248090	9			Z3	
248095	9,5	M 11		Z3	
248100	10			Z3	
248102	10,2	M 12		Z3	
248105	10,5			Z3	
248110	11			Z2	
248115	11,5			Z2	
248120	12	M 14		Z2	
248125	12,5			Z2	
248130	13			Z2	

Right hand cut, type N, 5% Cobalt alloyed, precision ground, bronze colour. Tip angle 135 deg., cross-ground to DIN 1412 C, self centering, cylindrical, industrial quality, extreme heat resistance for difficult-to-work materials e.g. Steel and alloyed steel, stainless steel grades A2/ A4, cast iron and cast steel, bronze, plastics.





... always the appropriate accessories for your machine!

COBALT HSS CO twist drill set, DIN 338, 19-piece



Right hand cut, type N, 5% Cobalt alloyed, precision ground, bronze colour. Tip angle 135 deg., cross-ground to DIN 1412 C, self centering, cylindrical, industrial quality, extreme heat resistance for difficult-to-work materials e.g. Steel and alloyed steel, stainless steel grades A2/ A4, cast iron and cast steel, bronze, plastics.

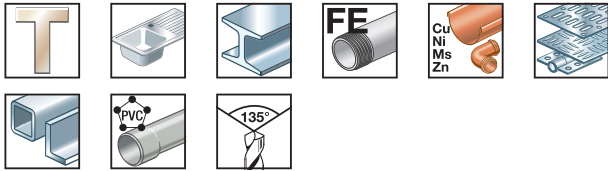

Art.-No.	Ø mm	By steps			Barcode
248920	1 - 10	0,5		1	 4 0093 12 489202



COBALT HSS CO twist drill set, DIN 338, 13-piece



Right hand cut, type N, 5% Cobalt alloyed, precision ground, bronze colour. Tip angle 135 deg., cross-ground to DIN 1412 C, self centering, cylindrical, industrial quality, extreme heat resistance for difficult-to-work materials e.g. Steel and alloyed steel, stainless steel grades A2/ A4, cast iron and cast steel, bronze, plastics.

Art.-No.	Ø mm	By steps			Barcode
421600	1,5 - 6,5 plus 3,3 and 4,2	0,5		6	 4 0093 14 216004

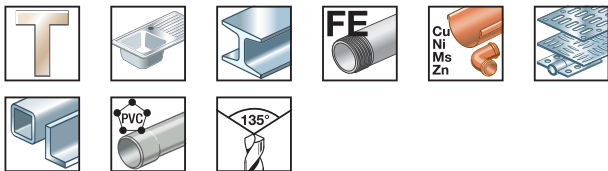

Drill bits for metal

COBALT HSS CO twist drill set, DIN 338, 6-piece



Art.-No.	Ø mm			Barcode
428040	2, 3, 4, 5, 6, 8		6	

Right hand cut, type N, 5% Cobalt alloyed, precision ground, bronze colour. Tip angle 135 deg., cross-ground to DIN 1412 C, self centering, cylindrical, industrial quality, extreme heat resistance for difficult-to-work materials e.g. Steel and alloyed steel, stainless steel grades A2/ A4, cast iron and cast steel, bronze, plastics.

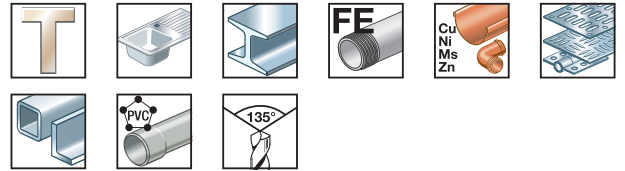

kwb-Info

A safer job.



Our eyes, as one of the most important sensory organs, must always be protected while working. That's why kwb has put together for all common situations when drilling, shaping, grinding or welding indoors or outdoors, a high quality protective eyewear range also suitable for spectacle-wearers.



You can find all the relevant information in our **Personal Protection catalogue**, or on the Internet at www.kwb.eu.



TITANIUM HSS twist drills, DIN 338, carded



Right hand cut, Type N, Titanium nitrided, precision ground, gold colour, tip angle 135 degrees, cross-ground to DIN 1412 C, self centring, cylindrical, industrial quality, high quality surface treatment for low friction and long working life even in extreme load conditions such as eg alloyed and unalloyed steel, cast steel, die castings, sintered steel, nickel silver, copper, bronze, hard plastics.

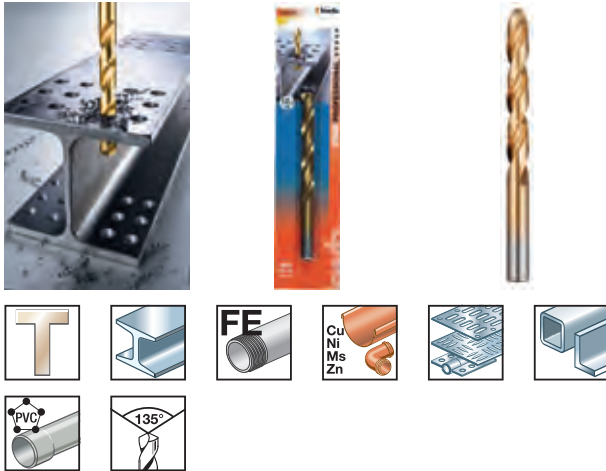

Art.-No.	Ø mm	Contents each pack	Tapping hole for thread size			Barcode
carded						
238610	1	1			5	4 0093 12 386 105
238615	1,5	1			5	4 0093 12 386 150
238620	2	1			5	4 0093 12 386 204
238625	2,5	1	M 3		5	4 0093 12 386 259
238630	3	1			5	4 0093 12 386 303
238633	3,3	1	M 4		5	4 0093 12 386 334
238635	3,5	1			5	4 0093 12 386 358
238640	4	1			3	4 0093 12 386 402
238642	4,2	1	M 5		3	4 0093 12 386 426
238645	4,5	1			3	4 0093 12 386 457
238650	5	1	M 6		3	4 0093 12 386 501
238655	5,5	1			3	4 0093 12 386 556
238660	6	1	M 7		3	4 0093 12 386 600
238665	6,5	1			3	4 0093 12 386 655
238670	7	1			2	4 0093 12 386 709
238680	8	1			2	4 0093 12 386 808
238690	9	1			2	4 0093 12 386 907
238700	10	1			2	4 0093 12 387 003
238720	12	1	M 14		1	4 0093 12 387 201
238730	13	1			1	4 0093 12 387 300

TITANIUM HSS twist drill set, DIN 338, 19-piece



Right hand cut, Type N, Titanium nitrided, precision ground, gold colour, tip angle 135 degrees, cross-ground to DIN 1412 C, self centring, cylindrical, industrial quality, high quality surface treatment for low friction and long working life even in extreme load conditions such as eg alloyed and unalloyed steel, cast steel, die castings, sintered steel, nickel silver, copper, bronze, hard plastics.

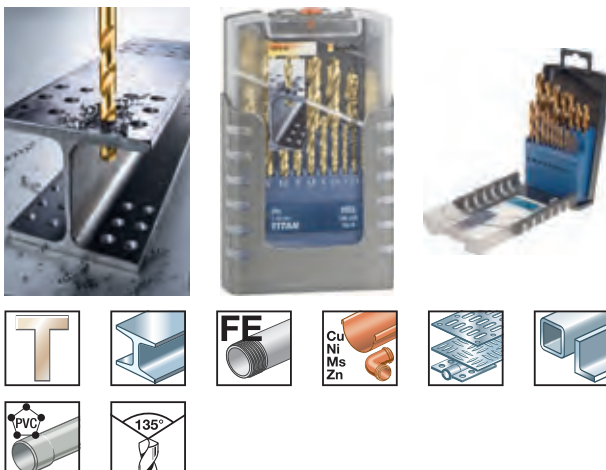

Art.-No.	Ø mm	By steps			Barcode
421820	1 - 10	0,5		1	4 0093 14 218 206

Drill bits for metal

TITANIUM HSS twist drill set, DIN 338, 13-piece



Art.-No.	Ø mm	By steps			Barcode
427140	1,5 - 6,5 plus 3,3 and 4,2	0,5		1	

Right hand cut, Type N, Titanium nitrided, precision ground, gold colour, tip angle 135 degrees, cross-ground to DIN 1412 C, self centring, cylindrical, industrial quality, high quality surface treatment for low friction and long working life even in extreme load conditions such as eg alloyed and unalloyed steel, cast steel, die castings, sintered steel, nickel silver, copper, bronze, hard plastics.

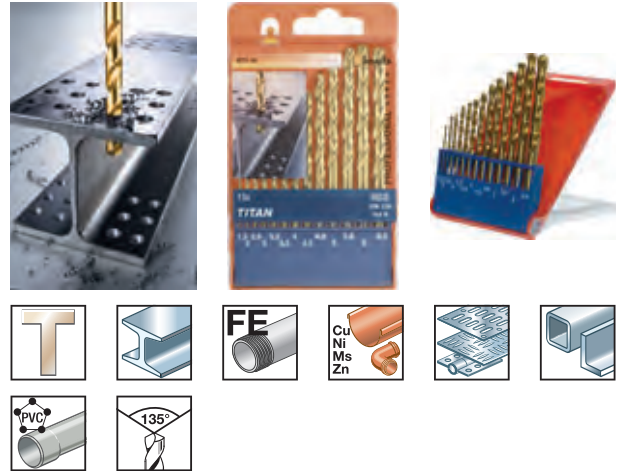

TITANIUM HSS twist drill set, DIN 338, 6-piece



Art.-No.	Ø mm			Barcode
427040	2, 3, 4, 5, 6, 8		1	

Right hand cut, Type N, Titanium nitrided, precision ground, gold colour, tip angle 135 degrees, cross-ground to DIN 1412 C, self centring, cylindrical, industrial quality, high quality surface treatment for low friction and long working life even in extreme load conditions such as eg alloyed and unalloyed steel, cast steel, die castings, sintered steel, nickel silver, copper, bronze, hard plastics.

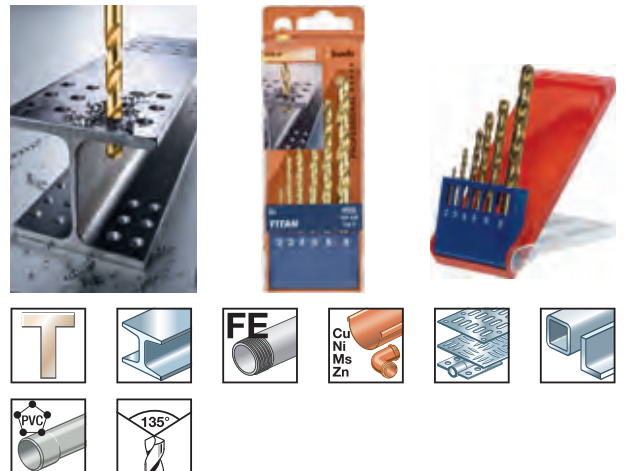

... always the appropriate accessories for your machine!

SILVER STAR HSS twist drills, DIN 338, carded



Right hand cut, type N, precision ground, self colour. Tip angle 135 deg., cross-ground to DIN 1412 C, self centering, cylindrical, industrial quality, for eg. steel and alloyed steel, cast steel, die castings, sintered steel, non-ferrous metals and hard plastics.







































Art.-No.	Ø mm	Contents each pack	Tapping hole for thread size			Barcode
carded						
206510	1	2			10	4 0093 12 065109
206515	1,5	2			10	4 0093 12 065154
206520	2	2			10	4 0093 12 065208
206525	2,5	2	M 3		10	4 0093 12 065253
206530	3	2	M 3,5		10	4 0093 12 065307
206532	3,2	1			10	4 0093 12 065321
206533	3,3	1	M 4		10	4 0093 12 065338
206535	3,5	1			10	4 0093 12 065352
206540	4	1			10	4 0093 12 065406
206542	4,2	1	M 5		10	4 0093 12 065420
206545	4,5	1			10	4 0093 12 065451
206548	4,8	1			10	4 0093 12 065482
206550	5	1	M 6		10	4 0093 12 065505
206555	5,5	1			10	4 0093 12 065550
206560	6	1	M 7		10	4 0093 12 065604
206565	6,5	1			10	4 0093 12 065659
206568	6,8	1	M 8		10	4 0093 12 065680
206570	7	1			10	4 0093 12 065703
206575	7,5	1			10	4 0093 12 065758
206580	8	1			10	4 0093 12 065802
206585	8,5	1	M10		10	4 0093 12 065857
206590	9	1			10	4 0093 12 065901
206595	9,5	1	M 11		10	4 0093 12 065956
206600	10	1			10	4 0093 12 066007
206602	10,2	1	M 12		5	4 0093 12 066021
206610	11	1			5	4 0093 12 066106
206620	12	1	M 14		5	4 0093 12 066205
206630	13	1			5	4 0093 12 066304

Drill bits for metal

Silver Star HSS twist drills, DIN 338, bulk

































Art.-No.	Ø mm	Tapping hole for thread size			Barcode
Bulk, in tube					
205003	0,3			Z10	
205004	0,4			Z10	
205005	0,5			Z10	
205006	0,6			Z10	
205007	0,7			Z10	
205008	0,8			Z10	
205009	0,9			Z10	
205010	1			Z10	
205011	1,1	M 1,4		Z10	
205012	1,2			Z10	
205013	1,3			Z10	
205014	1,4			Z10	
205015	1,5			Z10	
205016	1,6	M 2		Z10	
205017	1,7			Z10	
205018	1,8			Z10	
205019	1,9			Z10	
205020	2			Z10	
205021	2,1			Z10	
205022	2,2			Z10	
205023	2,3			Z10	
205024	2,4			Z10	
205025	2,5	M 3		Z10	
205026	2,6			Z10	
205027	2,7			Z10	
205028	2,8			Z10	
205029	2,9			Z10	
205030	3	M 3,5		Z10	
205031	3,1			Z10	
205032	3,1			Z10	
205033	3,3	M 4		Z10	
205034	3,4			Z10	
205035	3,5			Z10	
205036	3,6			Z10	
205037	3,7	M 4,5		Z10	
205038	3,8			Z10	

Right hand cut, type N, precision ground, self colour. Tip angle 135 deg., cross-ground to DIN 1412 C, self centering, cylindrical, industrial quality, for eg. steel and alloyed steel, cast steel, die castings, sintered steel, non-ferrous metals and hard plastics.





Silver Star HSS twist drills, DIN 338, bulk



Art.-No.	Ø mm	Tapping hole for thread size			Barcode
205039	3,9			Z10	
205040	4			Z10	
205041	4,1			Z10	
205042	4,2	M 5		Z10	
205043	4,3			Z10	
205044	4,4			Z10	
205045	4,5			Z10	
205046	4,6			Z10	
205047	4,7			Z10	
205048	4,8			Z10	
205049	4,9			Z10	
205050	5	M 6		Z10	
205051	5,1			Z10	
205052	5,2			Z10	
205053	5,3			Z10	
205054	5,4			Z10	
205055	5,5			Z10	
205056	5,6			Z10	
205057	5,7			Z10	
205058	5,8			Z10	
205059	5,9			Z10	
205060	6	M 7		Z10	
205061	6,1			Z10	
205062	6,2			Z10	
205063	6,3			Z10	
205064	6,4			Z10	
205065	6,5			Z10	
205066	6,6			Z10	
205067	6,7			Z10	
205068	6,8	M 8		Z10	
205069	6,9			Z10	
205070	7			Z10	
205071	7,1			Z10	
205072	7,2			Z10	
205073	7,3			Z10	
205074	7,4			Z10	
205075	7,5			Z10	

Silver Star HSS twist drills, DIN 338, bulk



Art.-No.	Ø mm	Tapping hole for thread size			Barcode
205076	7,6			Z10	4 009312 050761
205077	7,7			Z10	4 009312 050778
205078	7,8	M 9		Z10	4 009312 050785
205079	7,9			Z10	4 009312 050792
205080	8			Z10	4 009312 050808
205081	8,1			Z10	4 009312 050815
205082	8,2			Z10	4 009312 050822
205083	8,3			Z10	4 009312 050839
205084	8,4			Z10	4 009312 050846
205085	8,5	M 10 x 1,5		Z10	4 009312 050853
205086	8,6			Z10	4 009312 050860
205087	8,7			Z10	4 009312 050877
205088	8,8			Z10	4 009312 050884
205089	8,9			Z10	4 009312 050891
205090	9			Z10	4 009312 050907
205091	9,1			Z10	4 009312 050914
205092	9,2			Z10	4 009312 050921
205093	9,3			Z10	4 009312 050938
205094	9,4			Z10	4 009312 050945
205095	9,5	M 10 x 0,5		Z10	4 009312 050952
205096	9,6	M 11 x 1,5		Z10	4 009312 050969
205097	9,7			Z10	4 009312 050976
205098	9,8			Z10	4 009312 050983
205099	9,9			Z10	4 009312 050990
205100	10			Z10	4 009312 051003
205105	10,5	M 12 x 1,5		Z10	4 009312 051058
205110	11			Z5	4 009312 051102
205115	11,5			Z5	4 009312 051157
205120	12	M 14		Z5	4 009312 051201
205125	12,5			Z5	4 009312 051256
205130	13			Z5	4 009312 051300



... always the appropriate accessories for your machine!

SILVER STAR HSS twist drill set, DIN 338, 25-piece



Right hand cut, type N, precision ground, self colour. Tip angle 135 deg., cross-ground to DIN 1412 C, self centering, cylindrical, industrial quality, for eg. steel and alloyed steel, cast steel, die castings, sintered steel, non-ferrous metals and hard plastics.

Art.-No.	Ø mm	By steps			Barcode
205720	1 - 13	0,5		1	4 009312 05720

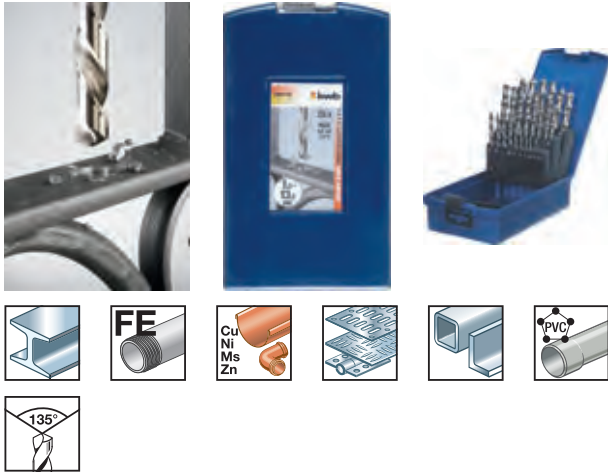

SILVER STAR HSS twist drill set, DIN 338, 19-piece



Right hand cut, type N, precision ground, self colour. Tip angle 135 deg., cross-ground to DIN 1412 C, self centering, cylindrical, industrial quality, for eg. steel and alloyed steel, cast steel, die castings, sintered steel, non-ferrous metals and hard plastics.

Art.-No.	Ø mm	By steps			Barcode
205920	1 - 10	0,5		4	4 009312 059207

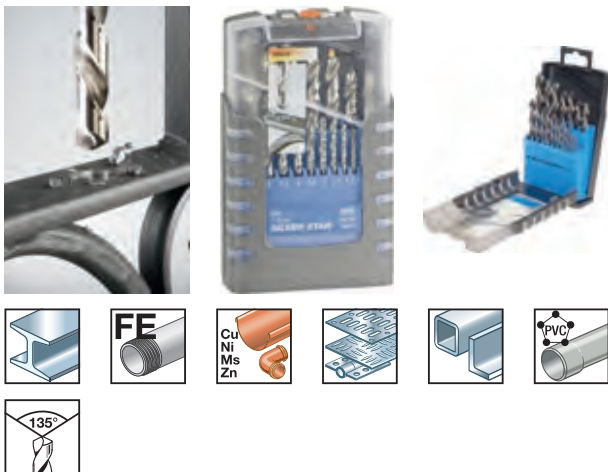

kwb-Info

Increase the life of your drill bits!

To get more use out of HSS drill bits and keep their performance up to scratch, we recommend the Drill Grinding Attachment from kwb. Fixes simply to an electric drill and sharpens twist drills with diameters between 3.5 and 10 mm

You can find this product on catalogue page 27.



Drill bits for metal

SILVER STAR HSS twist drill set, DIN 338, 13-piece



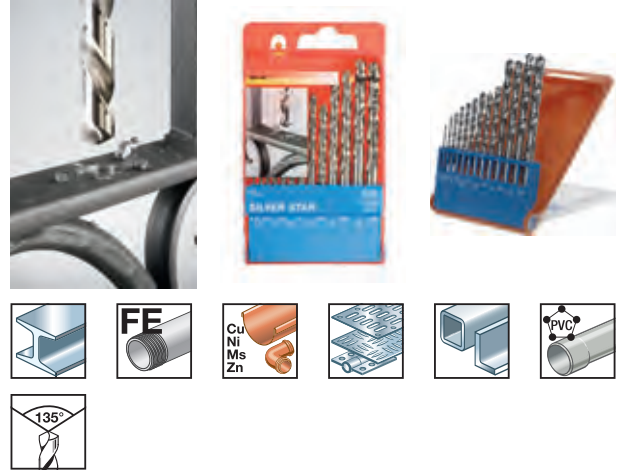

Art.-No.	Ø mm	By steps			Barcode
205840	1,5 - 6,5 plus 3,3 and 4,2	0,5		6	

Right hand cut, type N, precision ground, self colour. Tip angle 135 deg., cross-ground to DIN 1412 C, self centering, cylindrical, industrial quality, for eg. steel and alloyed steel, cast steel, die castings, sintered steel, non-ferrous metals and hard plastics.



SILVER STAR HSS twist drill set, DIN 338, 6-piece



Art.-No.	Ø mm			Barcode
205540	2, 3, 4, 5, 6, 8		6	

Right hand cut, type N, precision ground, self colour. Tip angle 135 deg., cross-ground to DIN 1412 C, self centering, cylindrical, industrial quality, for eg. steel and alloyed steel, cast steel, die castings, sintered steel, non-ferrous metals and hard plastics.

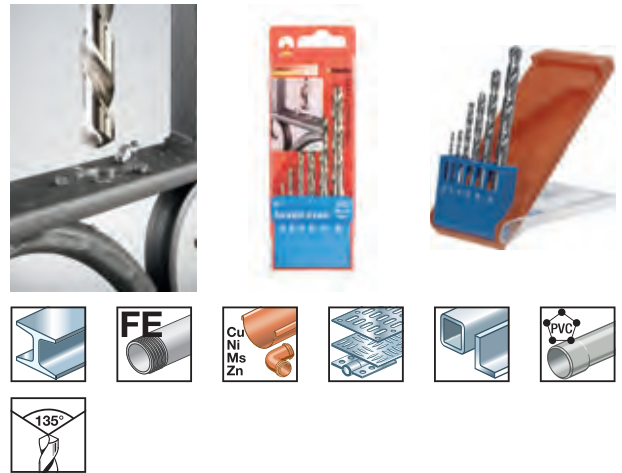







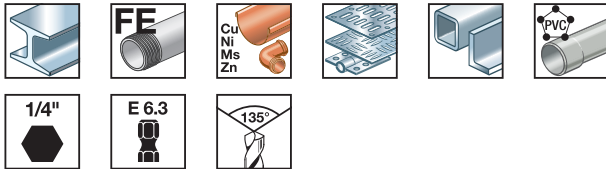





HSS twist drills with 1/4" hexagon shank, E6.3



HSS twist drills with 1/4" hexagon shank to ISO 1173, E 6.3, right hand cut type N, precision ground, for all cordless drivers and drills, and bit holders with 1/4" hexagon drive to ISO 1173, self colour, tip angle 135 deg., for alloyed and mild steel, cast steel, cast iron, sintered steel, non-ferrous metals and hard plastics.

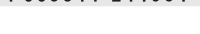

Art.-No.			Ø mm			Barcode
421102	15	21	2		10	
421103	15	21	3		10	
421104	20	28	4		10	
421105	25	34	5		10	
421106	27	34	6		10	

HSS twist drill set, 5-piece, with 1/4" hexagon shank, E6.3



HSS twist drills with 1/4" hexagon shank to ISO 1173, E 6.3, right hand cut type N, precision ground, for all cordless drivers and drills, and bit holders with 1/4" hexagon drive to ISO 1173, self colour, tip angle 135 deg., for alloyed and mild steel, cast steel, die castings, sintered steel, non-ferrous metals, hard plastics.

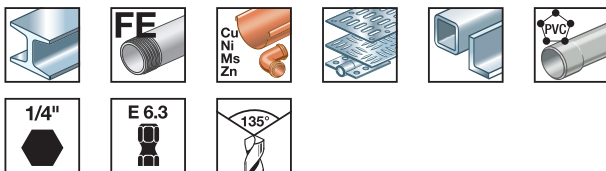





























Art.-No.	Ø mm			Barcode
421140	2, 3, 4, 5, 6		6	

Drill bits for metal

HSS twist drills, long series, DIN340, wallet with inlay card













































Art.-No.			Ø mm	Contents each pack			Barcode
Wallet with inlay card							
217030	65	100	3	1		10	
217035	75	112	3,5	1		10	
217040	78	119	4	1		10	
217045	80	126	4,5	1		10	
217050	85	132	5	1		10	
217055	90	139	5,5	1		10	
217060	90	139	6	1		10	
217065	95	149	6,5	1		10	
217070	100	156	7	1		10	
217080	110	165	8	1		10	
217090	115	175	9	1		10	
217100	120	194	10	1		10	

right hand cut, type N, precision ground, self colour. Tip angle 135 deg., cross-ground to DIN 1412 C, cylindrical, extra long, industrial quality, for eg. steel and alloyed steel, cast steel, die castings, sintered steel, non-ferrous metals and hard plastics.



HSS twist drills, DIN 338, carded











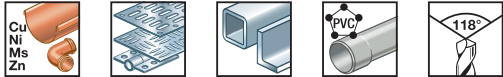











Art.-No.	Ø mm	Contents each pack	Tapping hole for thread size			Barcode
carded						
209610	1	2			10	
209615	1,5	2			10	
209620	2	2			10	
209625	2,5	2	M 3		10	
209630	3	2	M 3,5		10	
209632	3,2	1			10	
209633	3,3	1	M 4		10	
209635	3,5	1			10	
209640	4	1			10	
209642	4,2	1	M 5		10	
209645	4,5	1			10	
209648	4,8	1			10	
209650	5	1	M 6		10	
209655	5,5	1			10	
209660	6	1	M 7		10	
209665	6,5	1			10	
209668	6,8	1	M 8		10	
209670	7	1			10	
209675	7,5	1			10	
209678	7,8	1	M 9		10	

right hand cut, type N, roll forged, blue-black colour, steam hardened, tip angle 118 deg, for eg alloyed and mild steel, castings, non-ferrous metals, hard plastics.



HSS twist drills, DIN 338, carded











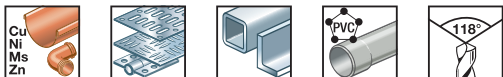















Art.-No.	Ø mm	Contents each pack	Tapping hole for thread size			Barcode
209680	8	1			10	
209685	8,5	1	M10		10	
209690	9	1			10	
209695	9,5	1	M 11		10	
209700	10	1			10	
209705	10,5	1			5	
209710	11	1			5	
209720	12	1	M 14		5	
209730	13	1			5	

HSS twist drills, DIN 338, bulk



right hand cut, type N, roll forged, blue-black colour, steam hardened, tip angle 118 deg, for eg alloyed and mild steel, castings, non-ferrous metals, hard plastics.







Art.-No.	Ø mm	Tapping hole for thread size			Barcode
Bulk, in tube					
204010	1			Z10	
204015	1,5			Z10	
204020	2			Z10	
204025	2,5	M 3		Z10	
204030	3	M 3,5		Z10	
204032	3,2			Z10	
204033	3,3	M 4		Z10	
204035	3,5			Z10	
204040	4			Z10	
204042	4,2	M 5		Z10	
204045	4,5			Z10	
204050	5	M 6		Z10	
204055	5,5			Z10	
204060	6	M 7		Z10	
204065	6,5			Z10	
204070	7			Z10	
204075	7,5			Z10	
204080	8			Z10	
204085	8,5	M10		Z10	
204090	9			Z10	
204100	10			Z10	
204105	10,5			Z10	

Drill bits for metal

HSS twist drills, DIN 338, bulk

★★★

Art.-No.	∅ mm	Tapping hole for thread size			Barcode
204110	11			Z5	
204120	12	M 14		Z5	
204130	13			Z5	

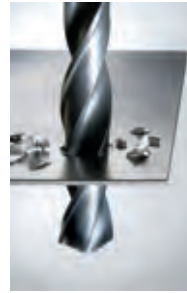

HSS twist drill set, DIN 338, 19-piece

★★★

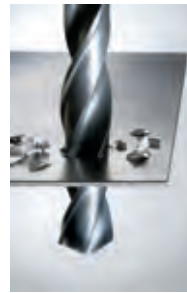

Art.-No.	∅ mm	By steps			Barcode
421920	1 - 10	0,5		4	

right hand cut, type N, roll forged, blue-black colour, steam hardened, tip angle 118 deg, for eg alloyed and mild steel, castings, non-ferrous metals, hard plastics.



HSS twist drill set, DIN 338, 13-piece

★★★

Art.-No.	∅ mm			Barcode
424140	2 - 8		6	

right hand cut, type N, roll forged, blue-black colour, steam hardened, tip angle 118 deg, for eg alloyed and mild steel, castings, non-ferrous metals, hard plastics.

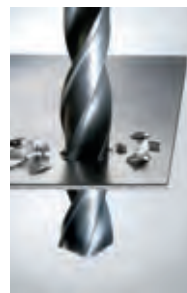

... always the appropriate accessories for your machine!

HSS twist drill set, DIN 338, 10-piece



right hand cut, type N, roll forged, blue-black colour, steam hardened, tip angle 118 deg, for eg alloyed and mild steel, castings, non-ferrous metals, hard plastics.

Art.-No.	Ø mm	By steps			Barcode
421340	1 - 10	1		6	4 009314 213409

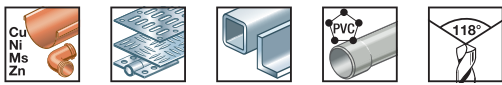
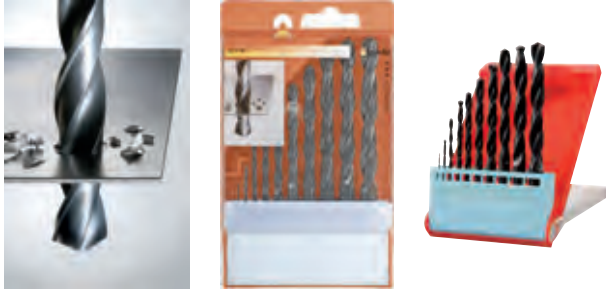

HSS twist drill set, DIN 338, 6-piece



right hand cut, type N, roll forged, blue-black colour, steam hardened, tip angle 118 deg, for eg alloyed and mild steel, castings, non-ferrous metals, hard plastics.

Art.-No.	Ø mm	By steps			Barcode
423140	2, 3, 4, 5, 6, 8			6	4 009314 231403

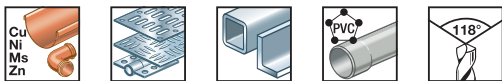

HSS twist drill set, DIN 338, 13-piece



right hand cut, type N, roll forged, blue-black colour, steam hardened, tip angle 118 deg, for eg alloyed and mild steel, castings, non-ferrous metals, hard plastics.



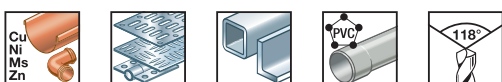





Art.-No.	Ø mm	By steps			Barcode
429040	1,5 - 6,5 plus 3,3 and 4,2	0,5		6	4 009314 290400



Drill bits for metal

Mixed drill set, 9-piece







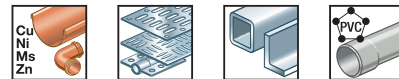







Art.-No.	Ø mm			Barcode
420200	HSS 3, 4, 5, 6, 8 and TCT 4, 5, 6, 8		6	
420300	HSS 3, 4, 5 and TCT 5, 6, 8 and wood 5, 6, 8		6	
420400	HSS 4, 6, 8 and TCT 4, 6, 8 and wood 4, 6, 8		6	

HSS and TCT masonry drills, wood drill bits.



HSS twist drills, with reduced shank, wallet

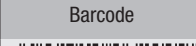

Art.-No.	Ø mm	Contents each pack			Barcode
Wallet with inlay card					
159105	10,5	1	10	5	
159110	11	1	10	5	
159120	12	1	10	5	
159130	13	1	10	5	
159140	14	1	10	5	
159150	15	1	10	5	
159160	16	1	10	5	
159170	17	1	13	1	
159180	18	1	13	1	
159190	19	1	13	1	
159200	20	1	13	1	

to DIN 338, right hand cut, type N, roll forged, blue-black colour, steam hardened, tip angle 118 deg., reduced shank, for drilling large diameters with standard electric drills, for eg alloyed and mild steel, castings, non-ferrous metals, hard plastics. Diameter 10.5 - 16mm for use in drills with 10mm capacity chucks and diameter 17 - 20mm for use in drills with 13mm capacity chucks.

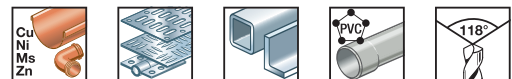

Drill Grinding Attachment, for twist drills



Art.-No.	Ø mm			Barcode
503200	3,5 - 10		2	

Drill grinding attachment, for HSS drills between diameters 3.5- 10mm, metal construction, 118 degree tip angle produced, for drills with 43mm Euro-collar.



... always the appropriate accessories for your machine!



CONCRETE AND MASONRY DRILL BITS

SDS Max hammer drill bits

SDS Max chisels

SDS Plus hammer drill bits

SDS Plus chisels

Concrete drill bits

Concrete and masonry drill bits

Extra long masonry drill bits

Concrete and masonry drill bits

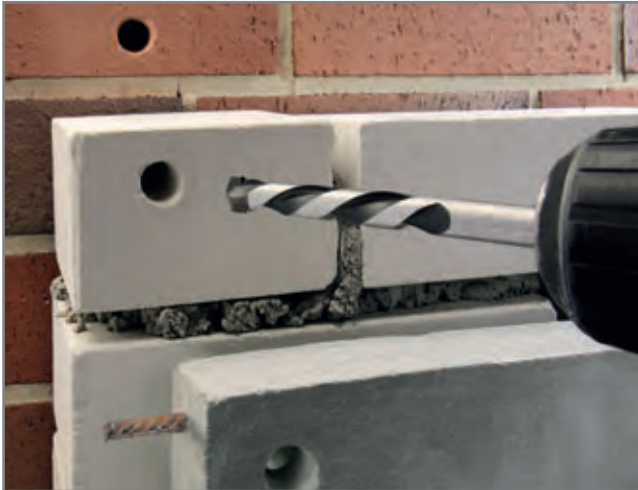

The advantages of concrete and masonry drill bits

- drill bits with cylindrical shank for use in impact and rotary drills
- drill bits with SDS Plus shank for use in hammer drills
- chisels with SDS Plus shank for use in hammer drills and chasing machines

Programme overview concrete and masonry drill bits



SDS Max hammer drill bits

★★★★★

Certificated hammer drill bits with fast-cutting tips, rebar resistant. High volume dust spirals for friction-free removal of drilling waste.



Page 32



SDS Max chisels for hammer drill bits

★★★★★

For renovation, reconstruction, breaking out, demolition. For heavy duty use, optimal weight distribution for efficient working.



Page 32 - 34



HB 44 SDS plus hammer drill bits

★★★★★

Certificated hammer drill bits with multiple spirals for optimal removal of drilling waste with minimal vibration.

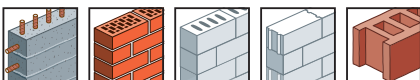

Page 35 - 38



HB 44 SDS plus chisels

★★★★★

For renovation and reconstruction. For heavy duty use, optimal weight distribution for efficient working.

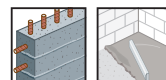

Page 39 - 40

Concrete and masonry drill bits

Our tip: CROSS TIP



CROSS TIP for SDS Plus hammer drills

★★★★★

4-part spiral for safe working in reinforced concrete without snagging, or breaking the carbide tip.

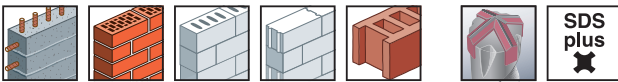

for

SDS
plus

Page 41

kwb-Info

The colour-coding system for concrete and masonry drill bit packaging

On the drill bit packaging, KWB sets out well-targeted end user information. The packaging attracts attention with a clear colour-coding system to indicate the correct drill for the relevant material with informative action photos.

- SDS MAX / SDS PLUS
- SUPER ROCKER[®]
- ROCKER[®]
- CONCRETE AND MASONRY DRILL BITS



BOSCH UNEO drill bits

★★★★★

Concrete and masonry drill bits, with patented SDS QUICK shank, Bosch licence.

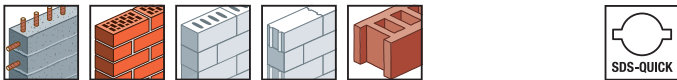

Page 42



SUPER ROCKER[®]

★★★★★

Asymmetrical spiral for optimal drilling waste removal. Hammer action-resistant high performance concrete and masonry drill bits, or all impact drills



Page 44 - 45

Shank:



Masonry drill bits

★★★★★

Smoothly formed semicircular spiral for good drilling waste removal, for all cordless and electric drills.

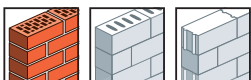

Page 45 - 47

Aufnahme:



Extra long masonry drill bits

★★★★★

Smoothly formed semicircular spiral for good drilling waste removal, for all rotary and impact drills.

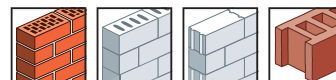

Page 47 - 48

Shank:











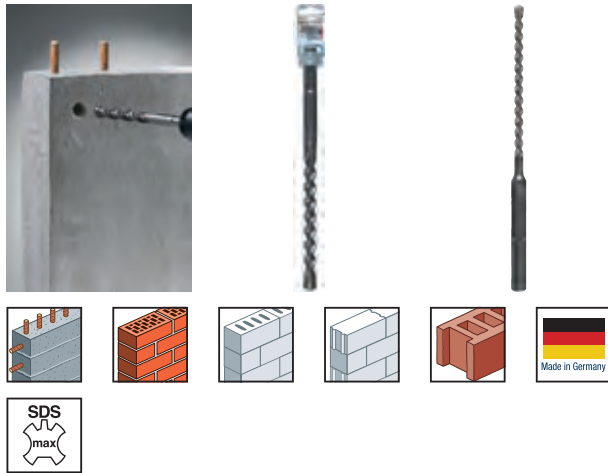



















... always the appropriate accessories for your machine!

SDS Max hammer drill bits, hanging clip



Hammer drill bits, SDS Max shank, multi cut rebar proof tip, short tip, self-centring drill point, high volume dust channels for friction-free waste removal and minimal heat build-up, reduced vibration, certified by the German Masonry Drill Testing Association (PGM), to the standards of the German Institute of Building Technology.









Art.-No.	 mm	 mm	Ø mm			Barcode
Hanging clip						
193412	200	340	12		1	
193414	200	340	14		1	
193415	200	340	15		1	
193416	200	340	16		1	
193418	200	340	18		1	
193730	250	370	30		1	
193732	250	370	32		1	
193740	250	370	40		1	
195220	400	520	20		1	
195222	400	520	22		1	
195224	400	520	24		1	
195225	400	520	25		1	
196912	550	690	12		1	

SDS Max chisel, point chisel



Chisel, SDS Max shank, high quality special steel, wear-reducing shot-blasted surfaces, optimal weight distribution for efficient power transmission. Vibration reduced.



Art.-No.	Length			Barcode
Point chisel, hanging clip				
190140	400		1	
190160	600		1	

kwb-Info

Vibration-optimised: what does it mean?









A special reflexive component in the shank directs the working forces of the kwb chisel. Rebound energy is

converted into impact force and thus minimises the working vibration experienced.



SDS Max chisel, flat chisel











Art.-No.		Length			Barcode
Flat chisel, hanging clip					
190228	25	280		1	
190240	25	400		1	
190260	25	600		1	

Chisel, SDS Max shank, high quality special steel, wear-reducing shot-blasted surfaces, optimal weight distribution for efficient power transmission. Vibration reduced.



SDS Max chisel, spade chisel







Art.-No.		Length			Barcode
Spade chisel, hanging clip					
190340	50	400		1	
190430	80	300		1	
190530	115	350		1	

Chisel, SDS Max shank, high quality special steel, wear-reducing shot-blasted surfaces, optimal weight distribution for efficient power transmission. Vibration reduced.



SDS Max chisel, grooving chisel



Art.-No.		Length			Barcode
Grooving chisel, hanging clip					
190630	26	300		1	

Chisel, SDS Max shank, high quality special steel, wear-reducing shot-blasted surfaces, optimal weight distribution for efficient power transmission. Vibration reduced.



SDS Max Chisel, channelling chisel



Chisel, SDS Max shank, high quality special steel, wear-reducing shot-blasted surfaces, optimal weight distribution for efficient power transmission. Vibration reduced.



Art.-No.		Length			Barcode
Channelling chisel, hanging clip					
190730	32	300		1	4 009311 907301

kwb-Info

For dry walls when drilling

kwb building materials and wood damp meter
Part.-No. 012100























- Universally usable device for measuring damp in construction materials and wood
- Ideal applications include renovation work, assessing water damage and buying timber
- Large, easy to read LCD display
- Suitable for a wide variety of materials
- With LED to illuminate dark areas



HB 44 SDS Plus Hammer Drills, 110/50mm, hanging clip



























Art.-No.			Ø mm			Barcode
110/50mm, hanging clip						
241134	50	110	4		5	
241135	50	110	5		5	
241136	50	110	6		5	
241137	50	110	7		5	
241138	50	110	8		5	
241140	50	110	10		5	
241185	50	110	5,5		5	
241195	50	110	6,5		5	

Hammer drill bits, SDS Plus shank, self centring tip, high temperature brazed, multi-phase spiral for optimal waste removal, minimal friction and heat build-up, minimal vibration, certified by the German drill bit testing organisation (PGM), meeting the standards of the German Institute of Building Technology



HB 44 SDS Plus Hammer Drills, 160/100mm, hanging clip



Art.-No.			Ø mm			Barcode
160/100mm, hanging clip						
241635	100	160	5		5	
241685	100	160	5,5		5	
241636	100	160	6		5	
241695	100	160	6,5		5	
241637	100	160	7		5	
241638	100	160	8		5	
241640	100	160	10		5	
241642	100	160	12		1	
241644	100	160	14		1	
241645	100	160	15		1	

Hammer drill bits, SDS Plus shank, self centring tip, high temperature brazed, multi-phase spiral for optimal waste removal, minimal friction and heat build-up, minimal vibration, certified by the German drill bit testing organisation (PGM), meeting the standards of the German Institute of Building Technology









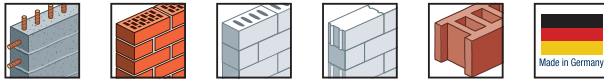













HB 44 SDS Plus Hammer Drill 210/150mm, hanging clip



Hammer drill bits, SDS Plus shank, self centring tip, high temperature brazed, multi-phase spiral for optimal waste removal, minimal friction and heat build-up, minimal vibration, certified by the German drill bit testing organisation (PGM), meeting the standards of the German Institute of Building Technology











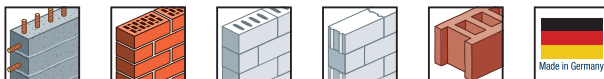











Art.-No.			Ø mm			Barcode
210/150mm, hanging clip						
242136	150	210	6		1	
242138	150	210	8		1	
242140	150	210	10		1	
242142	150	210	12		1	
242144	150	210	14		1	
242146	150	210	16		1	
242148	150	200	18		1	
242150	150	200	20		1	

HB 44 SDS Plus Hammer Drills, 260/200mm, hanging clip



















Hammer drill bits, SDS Plus shank, self centring tip, high temperature brazed, multi-phase spiral for optimal waste removal, minimal friction and heat build-up, minimal vibration, certified by the German drill bit testing organisation (PGM), meeting the standards of the German Institute of Building Technology



Art.-No.			Ø mm			Barcode
260/200mm, hanging clip						
242636	200	260	6		1	
242638	200	260	8		1	
242640	200	260	10		1	
242642	200	260	12		1	
242644	200	260	14		1	
242645	200	260	15		1	
242652	200	260	22		1	
242654	200	260	24		1	

HB 44 SDS Plus Hammer Drills 310/250mm, hanging clip







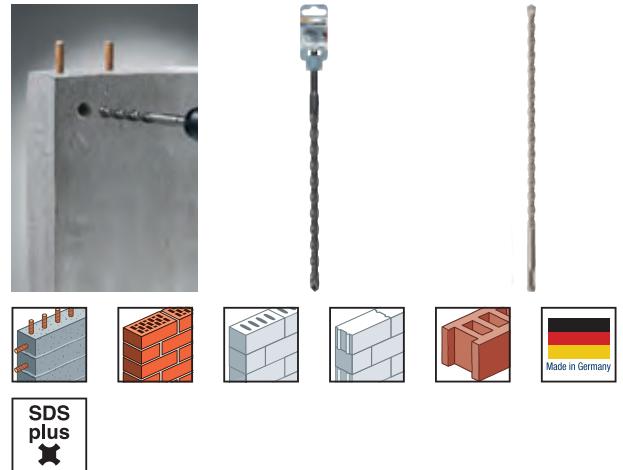



















Art.-No.			Ø mm			Barcode
310/250mm, hanging clip						
243136	250	310	6		1	
243138	250	310	8		1	
243140	250	310	10		1	
243144	250	310	14		1	
243146	250	310	16		1	
243148	250	310	18		1	
243150	250	310	20		1	

Hammer drill bits, SDS Plus shank, self centring tip, high temperature brazed, multi-phase spiral for optimal waste removal, minimal friction and heat build-up, minimal vibration, certified by the German drill bit testing organisation (PGM), meeting the standards of the German Institute of Building Technology



HB 44 SDS Plus Hammer Drills 460/400mm, hanging clip



Art.-No.			Ø mm			Barcode
460/400mm, hanging clip						
244638	400	460	8		1	
244640	400	460	10		1	
244642	400	460	12		1	
244644	400	460	14		1	
244646	400	460	16		1	
244648	400	450	18		1	
244650	400	450	20		1	
244652	400	450	22		1	
244654	400	450	24		1	
244655	400	450	25		1	



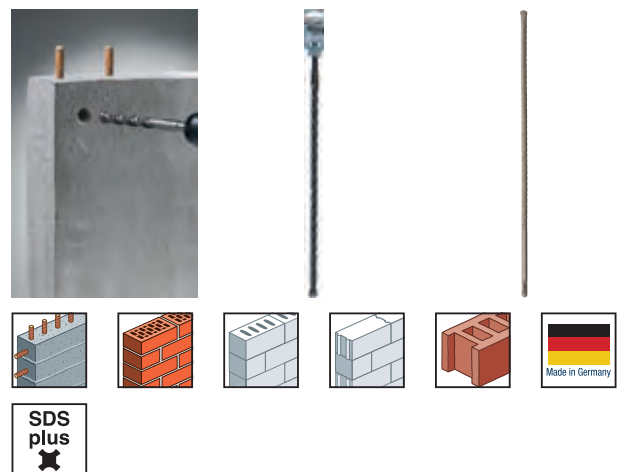



Hammer drill bits, SDS Plus shank, self centring tip, high temperature brazed, multi-phase spiral for optimal waste removal, minimal friction and heat build-up, minimal vibration, certified by the German drill bit testing organisation (PGM), meeting the standards of the German Institute of Building Technology



HB 44 SDS Plus Hammer Drill Set, 7-piece



Hammer drill bits, SDS Plus shank, self-centring drill point, high temperature brazed, multiple spirals for optimal waste removal, minimal friction and heat build-up, reduced vibration, certified by the German Masonry Drill Testing Association (PGM), to the standards of the German Institute of Building Technology.



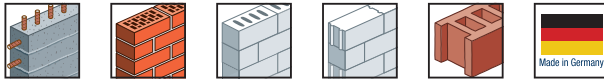







Art.-No.			Ø mm			Barcode
240700	50/100	110/160	5, 6, 8 + 6, 8, 10, 12		1	 4 0093 12 407008



HB 44 SDS Plus Hammer Drill Set, 4-piece





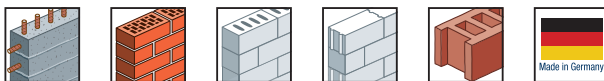

Hammer drill bits, SDS Plus shank, self-centring drill point, high temperature brazed, multiple spirals for optimal waste removal, minimal friction and heat build-up, reduced vibration, certified by the German Masonry Drill Testing Association (PGM), to the standards of the German Institute of Building Technology.

Art.-No.			Ø mm			Barcode
240400	50	110	5, 6, 8, 10		2	 4 0093 12 404007
240500	50/100	110/180	5, 6, 8, 10		1	 4 0093 12 405004
240800	100	160	5, 6, 8, 10		1	 4 0093 12 408005



SDS Plus chisel for hammer drills, point chisel







Art.-No.				Barcode
Point chisel, hanging clip				
247210	250		1	

Chisel, SDS Plus shank, high quality special steel, wear-reducing shot-blasted surfaces, optimal weight distribution for efficient power transmission. Vibration reduced.



SDS Plus chisel for hammer drills, flat chisel







Art.-No.				Barcode
Flat chisel, hanging clip				
247302	250		1	

Chisel, SDS Plus shank, high quality special steel, wear-reducing shot-blasted surfaces, optimal weight distribution for efficient power transmission. Vibration reduced.



SDS Plus chisel for hammer drills, spade chisel



Art.-No.				Barcode
Spade chisel, hanging clip				
247304	250		1	

Chisel, SDS Plus shank, high quality special steel, wear-reducing shot-blasted surfaces, optimal weight distribution for efficient power transmission. Vibration reduced.







SDS Plus chisel for hammer drills, grooving chisel



Chisel, SDS Plus shank, high quality special steel, wear-reducing shot-blasted surfaces, optimal weight distribution for efficient power transmission. Vibration reduced.







Art.-No.				Barcode
Channelling chisel, hanging clip				
247410	250		1	

SDS Plus chisel for hammer drills, tile lifting chisel



Chisel, SDS Plus shank, high quality special steel, wear-reducing shot-blasted surfaces, optimal weight distribution for efficient power transmission. Vibration reduced.



Art.-No.				Barcode
Tile lifting chisel, hanging clip				
247504	250		1	

kwb-Info

Always the right chisel from kwb!



**Point chisel/
Flat chisel**

- Breaking and demolition in masonry and concrete
- Alteration work in masonry and concrete
- Restoration of joints
- Breaking out around reinforcements



Spade chisel

- Mortar and debris removal
- Removal of excess concrete from shuttering
- Refurbishment of steel structures



Grooving chisel

- Chasing out for channel/conduit































































Tile lifting chisel

- For removing wall or floor tiles

CROSS-TIP Hammer drill bits, 4-way tip, hanging clip



Art.-No.		Ø mm			Barcode
Hanging clip					
260504	110	4		1	
260505	110	5		1	
260506	110	6		1	
260508	110	8		1	
260510	110	10		1	
260555	110	5,5		1	
261005	160	5		1	
261006	160	6		1	
261007	160	7		1	
261008	160	8		1	
261010	160	10		1	
261012	160	12		1	
261014	160	14		1	
261506	210	6		1	
261508	210	8		1	
261510	210	10		1	
261512	210	12		1	
261514	210	14		1	
262006	260	6		1	
262008	260	8		1	
262010	260	10		1	
262012	260	12		1	
262014	260	14		1	
264010	460	10		1	
264012	460	12		1	
264014	460	14		1	
264016	450	16		1	
264018	450	18		1	
264020	450	20		1	

Hammer drill bits, SDS Plus shank, CROSS-TIP 4-way cutting tip, ideal for use in reinforced concrete, no snagging, high temperature brazed, multi-phase spiral for optimal waste removal, easy drilling with high efficiency with low vibration and smooth running. Ideal for drilling wall plug and anchor fixing holes in concrete.

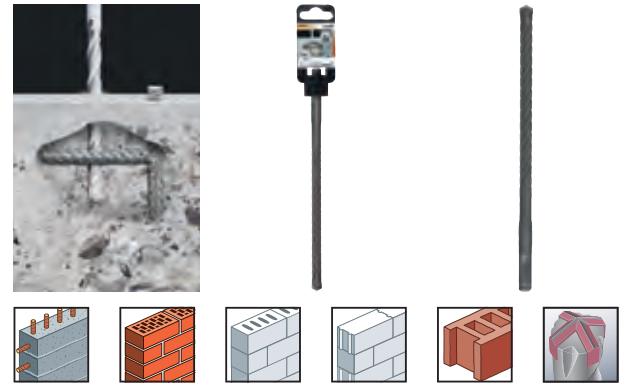

for









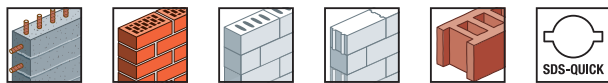



... always the appropriate accessories for your machine!

Concrete drills for Bosch UNEO, SDS Quick shank, carded



Concrete and masonry drill bits, SDS QUICK shank, tungsten carbide tipped, high temperature brazed, for BOSCH UNEO. Also can be used in standard rotary and impact drills and lightweight hammer drills.











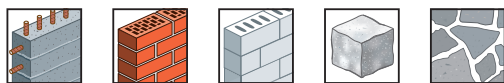















Art.-No.	Ø mm			Barcode
carded				
035640	4		5	
035650	5		5	
035660	6		5	
035680	8		5	
035700	10		5	

ROCKER® Concrete and masonry drill bits, ISO 5468, carded



Concrete and masonry drills, to ISO 5468, tungsten carbide tipped, high temperature brazed, laterally and vertically secured TC plates, chip removing, asymmetrical profile spiral for optimal waste removal, hammer resistant high performance drill bits for all electric drills, chemical black finish, ground spiral, for granite, concrete, masonry, natural and reconstituted stone, limestone



Art.-No.	Ø mm			Barcode
carded				
044630	3		10	
044640	4		10	
044650	5		10	
044655	5,5		10	
044660	6		10	
044670	7		10	
044680	8		10	
044700	10		10	
044720	12		5	
044740	14		5	
044760	16		5	

kwb-Info

A safer job.

Our eyes, as one of the most important sensory organs, must always be protected while working. That's why kwb has put together for all common situations when drilling, shaping, grinding or welding indoors or outdoors, a high quality protective eyewear range

also suitable for spectacle-wearers.

















Further information at: www.kwb.eu.

Concrete and masonry drill bits

ROCKER[®] Concrete and masonry drills, ISO 5468, long series, carded







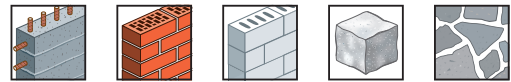

Art.-No.		Ø mm				Barcode
carded						
045050	150	5	cyl.		5	
045060	150	6	cyl.		5	
045080	250	8	cyl.		5	
045100	250	10	cyl.		5	
045120	250	12	10		5	

Concrete and masonry drills, to ISO 5468, tungsten carbide tipped, high temperature brazed, laterally and vertically secured TC plates, chip removing, asymmetrical profile spiral for optimal waste removal, hammer resistant high performance drill bits for all electric drills, chemical black finish, ground spiral, for granite, concrete, masonry, natural and reconstituted stone, limestone



ROCKER[®] Concrete and masonry drill sets, ISO 5468, 4- and 5-piece



Art.-No.	Ø mm			Barcode
044300	3, 4, 5, 6, 8		6	
044800	5, 6, 8, 10		6	

Concrete and masonry drills, to ISO 5468, tungsten carbide tipped, high temperature brazed, laterally and vertically secured TC plates, chip removing, asymmetrical profile spiral for optimal waste removal, hammer resistant high performance drill bits for all electric drills, chemical black finish, ground spiral, for granite, concrete, masonry, natural and reconstituted stone, limestone

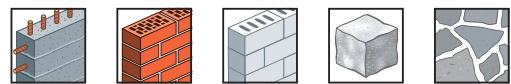

ROCKER® Concrete and masonry drill set, ISO 5468



Concrete and masonry drills, to ISO 5468, tungsten carbide tipped, high temperature brazed, laterally and vertically secured TC plates, chip removing, asymmetrical profile spiral for optimal waste removal, hammer resistant high performance drill bits for all electric drills, chemical black finish, ground spiral, for granite, concrete, masonry, natural and reconstituted stone, limestone



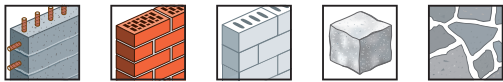



















Art.-No.	Ø mm			Barcode
044568	5, 6, 8		6	 4 009310 445682



SUPER ROCKER® hex shank concrete and masonry drills, ISO 5468, carded



Concrete and masonry drills, to ISO 5468, tungsten carbide tipped, high temperature brazed, laterally and vertically secured TC plates, hexagon shank, chip removing, asymmetrical profile spiral for optimal waste removal, hammer resistant high performance drill bits for all electric drills, chemical black finish, ground spiral, for granite, concrete, masonry, natural and reconstituted stone, limestone.



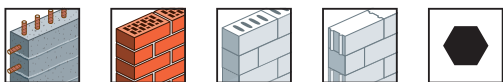

Art.-No.	Ø mm	 mm			Barcode
carded					
050640	4	3,1		10	 4 009310 506406
050650	5	3,9		10	 4 009310 506505
050655	5,5	3,9		10	 4 009310 506550
050660	6	4,7		10	 4 009310 506604
050670	7	5,6		10	 4 009310 506703
050680	8	6		10	 4 009310 506802
050700	10	7,7		10	 4 009310 507007
050720	12	8,4		5	 4 009310 507205
050740	14	9,3		5	 4 009310 507403
050760	16	9,3		5	 4 009310 507601



Concrete and masonry drill bits

SUPER ROCKER[®] hex shank concrete and masonry drill set, ISO 5468, 4-piece







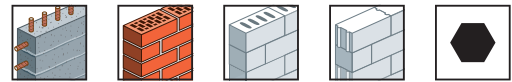





Art.-No.	Ø mm	Contents each pack			Barcode
050800	5, 6, 8, 10	4		1	

Concrete and masonry drills, to ISO 5468, tungsten carbide tipped, high temperature brazed, laterally and vertically secured TC plates, hexagon shank, chip removing, asymmetrical profile spiral for optimal waste removal, hammer resistant high performance drill bits for all electric drills, chemical black finish, ground spiral, for granite, concrete, masonry, natural and reconstituted stone, limestone.



Masonry drill bits with 1/4" hexagon shank, E6.3



Art.-No.			Ø mm			Barcode
421004	30	45	4		10	
421005	45	60	5		10	
421006	50	75	6		10	

Masonry drill bits, 1/4" hexagon shank to ISO 1173, E 6.3, tungsten carbide tipped, high temperature brazed, smoothly formed half-round spiral for good waste removal, for all cordless and mains drills and bitholders, phosphated surfaces, for masonry, natural and artificial stone, limestone.

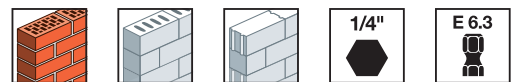

kwb-Info

A safer job.

Many jobs will generate dust and particles, or vapours and gases, or will involve working with potentially harmful substances.

Protect your lungs and airways against these hazards!

This is why kwb has put together a comprehensive range of protective masks, with and without breather valves.

For all common applications in the specified breathing protection categories.

Weitere Infos unter:
www.kwb.eu.





























Masonry drill bits, ISO 5468, carded



Masonry drill bits, to ISO 5468, tungsten carbide tipped, high temperature brazed, smoothly formed half-round spiral for good waste removal, impact resistant drill bits for all rotary and impact drills, shot-blasted grey-coloured surfaces, for masonry, natural and artificial stone, limestone.







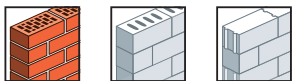

Art.-No.	Ø mm	T mm			Barcode
carded					
039630	3	cyl.		10	
039640	4	cyl.		10	
039650	5	cyl.		10	
039655	5,5	cyl.		10	
039660	6	cyl.		10	
039665	6,5	cyl.		10	
039670	7	cyl.		10	
039680	8	cyl.		10	
039700	10	cyl.		10	
039720	12	10		5	
039740	14	10		5	
039760	16	12		1	

Masonry drill sets, 5- and 8-piece, ISO 5468



Masonry drill bits, to ISO 5468, tungsten carbide tipped, high temperature brazed, smoothly formed half-round spiral for good waste removal, impact resistant drill bits for all rotary and impact drills, shot-blasted grey-coloured surfaces, for masonry, natural and artificial stone, limestone.









Art.-No.	Ø mm	Contents each pack			Barcode
039500	4, 5, 6, 8, 10	5		6	
039800	3, 4, 5, 6, 7, 8, 9, 10	8		6	

Concrete and masonry drill bits

Masonry drill set ISO 5468, TCT 5- and 8-piece







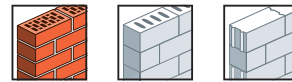

















Art.-No.	Ø mm	Contents each pack			Barcode
038500	4, 5, 6, 8, 10	5		6	
038900	3, 4, 5, 6, 7, 8, 9, 10	8		6	

Masonry drill set, to ISO 5468, tungsten carbide tipped, impact resistant drill bits for all rotary and impact drills.



PROFI extra long masonry drill, 200mm, wallet with inlay card



Art.-No.		Ø mm	max. RPM				Barcode
200mm, wallet with inlay card							
041055	200	5,5	1.600	cyl.		5	
041006	200	6	1.600	cyl.		5	
041065	200	6,5	1.600	cyl.		5	
041007	200	7	1.600	cyl.		5	
041008	200	8	1.600	cyl.		5	
041010	200	10	1.200	cyl.		5	
041012	200	12	1.200	cyl.		5	
041014	200	14	800	10		1	
041016	200	16	800	10		1	

Extra long wall drills, to ISO 5468, tungsten carbide tipped, high temperature brazed, smoothly formed spirals half-round for good waste removal, impact resistant drill bits for all rotary and impact drills, shot-blasted surfaces grey coloured, for masonry, natural and artificial stone, limestone.

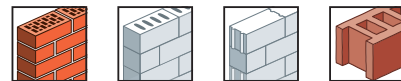

kwb-Info

A safer job.

During DIY, building work, or during sport and leisure, recommended safe noise limits are often exceeded. Without the right protection your hearing can be damaged.

This is why kwb has put together a hearing protection programme for all common situations,

from simple ear plugs to professional ear defenders.

Further information at:
www.kwb.eu.











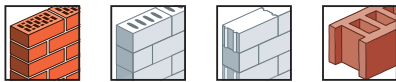

... always the appropriate accessories for your machine!

PROFI extra long masonry drill, 400mm, wallet with inlay card



Extra long wall drills, to ISO 5468, tungsten carbide tipped, high temperature brazed, smoothly formed spirals half-round for good waste removal, impact resistant drill bits for all rotary and impact drills, shot-blasted surfaces grey coloured, for masonry, natural and artificial stone, limestone.











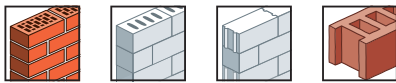







Art.-No.	 mm	Ø mm	max. Rpm	 mm			Barcode
400mm, wallet with inlay card							
041806	400	6	650	cyl.		1	
041808	400	8	650	cyl.		1	
041810	400	10	650	cyl.		1	
041812	400	12	500	cyl.		1	
041814	400	14	500	10		1	
041816	400	16	500	○10		1	
041818	400	18	300	○10		1	
041820	400	20	300	○11		1	

PROFI extra long masonry drill, 600mm, wallet with inlay card



Extra long wall drills, to ISO 5468, tungsten carbide tipped, high temperature brazed, smoothly formed spirals half-round for good waste removal, impact resistant drill bits for all rotary and impact drills, shot-blasted surfaces grey coloured, for masonry, natural and artificial stone, limestone.



Art.-No.	 mm	Ø mm	max. Rpm	 mm			Barcode
600mm, wallet with inlay card							
041610	600	10	650	cyl.		1	
041612	600	12	500	cyl.		1	
041614	600	14	500	10		1	
041616	600	16	500	○10		1	
041618	600	18	300	○10		1	
041620	600	20	300	○11		1	

Dust catcher



Dust catcher, for all masonry drills between 4-10mm in diameter, for dust-free collection of drilling waste while drilling in masonry and concrete in walls or ceilings.

Art.-No.	Ø mm			Barcode
045400	4 - 10		1	



SPECIALISED DRILL BITS

EASY CUT multi-material drill bits
Drill bits for porcelain and hard tiles
Glass and tile drills



Specialised drill bits



The benefits of specialised drill bits

- Multi-material drill bits for electric drills and also with SDS shank for use with hammer drills. For universal use in wood, metal, tiles, ceramics, masonry and plastics
- Glass and tile drills for use in glass and ceramic tiles
- Porcelain drill bits for especially hard tiles

Programme overview EASY CUT multi-material drill bits



EASY CUT multi-material drill bits SDS Plus ★★★★★

For all SDS hammer drills with hammer stop, with MS 5 spiral, extra hard Tungsten Titanium-carbide-tips, diamond-ground cutting edges.

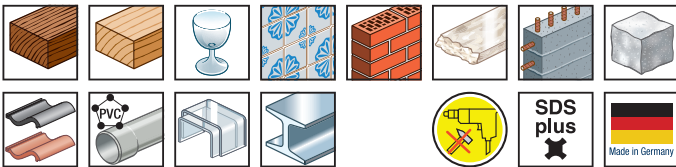

Page 52



EASY CUT multi-material drill bits ★★★★★



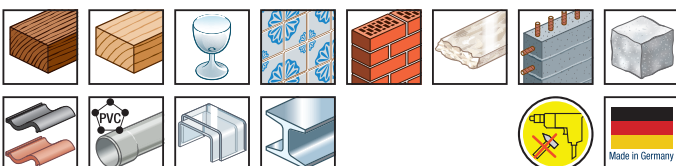



For all rotary and impact drills, extra hard Tungsten Titanium-carbide tips, diamond-ground cutting edges.



Page 52 - 53





Usage guide for EASY CUT multi-material drill bits

	Diameter in mm		Material
	4	16	
Revolutions per minute	2350	1500	 Softwoods
	1880	1030	 Ceramics
	1580	800	 Masonry, marble, reconstituted stone, concrete, granite, brick, plastics, acrylic
	1120	640	 Steel, cast steel
	1700	510	 Hardwoods
	850	410	 Glass, crystal

kwb-Info

The colour-coding system for specialised drill bit packaging

On the drill bit packaging, KWB sets out well-targeted end user information. The packaging attracts attention with a clear colour-coding system to indicate the correct drill for the relevant material with informative action photos.

-  EASY CUT MULTI-MATERIAL
-  PORCELAIN
-  GLASS

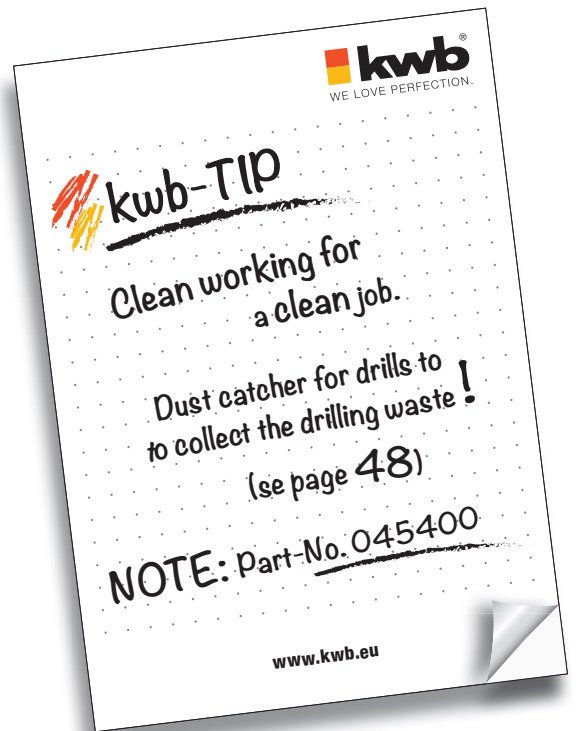

Programme overview Porcelain drill bits, glass drills



Porcelain drill bits

★★★★★

For all rotary and impact machines; water-cooling will increase drilling performance and the life of the drill bit.



Page 53 - 54



Glass drills

★★★★★

For all rotary and impact machines, coolants include water, turpentine or paraffin.



Page 55

kwb-Info

A safer Job



Our eyes, as one of the most important sensory organs, must always be protected while working. That's why kwb has put together for all common situations when drilling, shaping, grinding or welding indoors or outdoors, a high quality protective eyewear range also suitable for spectacle-wearers.

You can find all the relevant information in our **Personal Protection catalogue**, or on the Internet at www.kwb.eu.









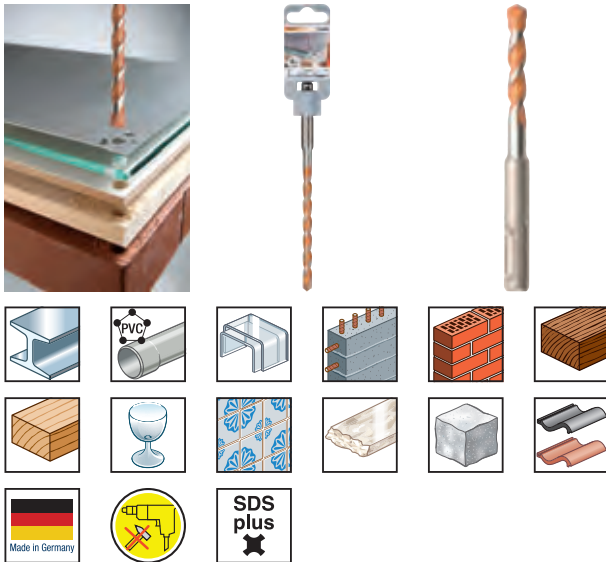





EASY CUT multi-material hammer drill bits with SDS-Plus shank, hanging clip



Multi-material drill bits, SDS Plus shank, tungsten carbide tipped, extra hard Tungsten-Titanium-Carbide tips, diamond ground cutting edges, high temperature brazed, chip removing, MS 5 spiral for optimal waste removal, for all SDS Plus hammer drills with hammer stop. Copper colour, ground surfaces, for masonry, marble, reconstituted stone, concrete, granite, brick, ceramics, hard- and softwoods, plastics and acrylic, alloyed and unalloyed steel, glass and crystal.











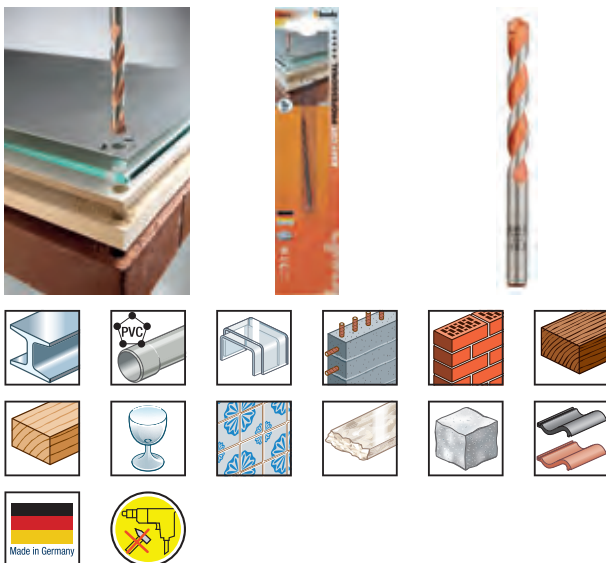









Art.-Nr.	Contents each pack			EAN
Hanging clip				
266105	5,5 x 50 x 110 mm		1	
266606	6,0 x 110 x 160 mm		1	
266608	8,0 x 110 x 160 mm		1	
266610	10,0 x 110 x 160 mm		1	
266612	12,0 x 110 x 160 mm		1	

EASY CUT multi-material drill bits, carded



Multi-material drill bits, tungsten carbide tipped, extra hard Tungsten-Titanium-Carbide tips, diamond ground cutting edges, high temperature brazed, chip removing, asymmetrical spiral for optimal waste removal, for all rotary and impact drills. Copper colour, ground surfaces, for masonry, marble, reconstituted stone, concrete, granite, brick, ceramics, hard- and softwoods, plastics and acrylic, alloyed and unalloyed steel, glass and crystal.

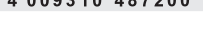

Art.-Nr.	Ø mm			EAN
carded				
048630	3		10	
048640	4		10	
048650	5		10	
048660	6		10	
048670	7		10	
048680	8		10	
048700	10		10	
048720	12		10	

Specialised drill bits

EASY CUT multi-material drill set, 5-piece



Art.-Nr.	Ø mm			EAN
048300	3, 4, 5, 6, 8		6	

Multi-material drill bits, tungsten carbide tipped, extra hard Tungsten-Titanium-Carbide tips, diamond ground cutting edges, high temperature brazed, chip removing, asymmetrical spiral for optimal waste removal, for all rotary and impact drills. Copper colour, ground surfaces, for masonry, marble, reconstituted stone, concrete, granite, brick, ceramics, hard- and softwoods, plastics and acrylic, alloyed and unalloyed steel, glass and crystal.



kwb-Info

Important advice on drilling different materials!

The EASY CUT multi-material drill bit is suitable for a wide range of materials. To achieve the best and most professional drilling results, the drill bit should be sharpened BEFORE changing to a different material.

kwb points you towards the Drill Grinding Attachment, which makes your drill bit ready for the next job in no time.

You can find this small gadget with the big effect in our catalogue on page 27.

... always the appropriate accessories for your machine!









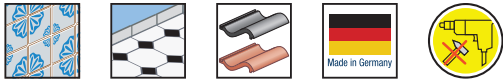
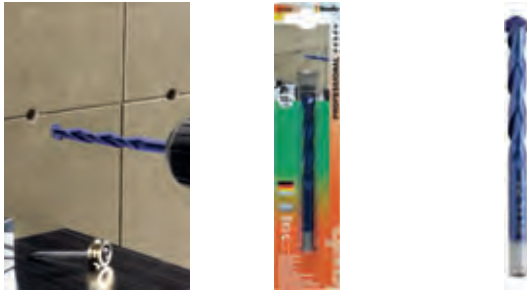





Drills for hard Ceramic Tiles, carded



Hard tile drill bit, tungsten carbide tipped, extra hard tungsten-Titanium-tungsten carbide tipped drilling tips, diamond-ground cutting edges, high temperature brazed, chip removing, asymmetrical spiral for optimal waste removal, for all rotary and impact drills, blue colour, for tiles and porcelain to hardness 9, ceramics, roof tiles.



Art.-No.	Ø mm			Barcode
carded				
051340	4		1	 4 009310 513404
051350	5		1	 4 009310 513503
051360	6		1	 4 009310 513602
051380	8		1	 4 009310 513800
051400	10		1	 4 009310 514005

Drill Set for hard Ceramic Tiles, 4-piece



Hard tile drill bit, tungsten carbide tipped, extra hard tungsten-Titanium-tungsten carbide tipped drilling tips, diamond-ground cutting edges, high temperature brazed, chip removing, asymmetrical spiral for optimal waste removal, for all rotary and impact drills, blue colour, for tiles and porcelain to hardness 9, ceramics, roof tiles.

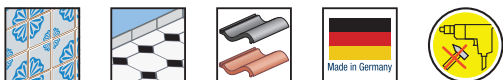

Art.-No.	Ø mm			Barcode
051300	4, 5, 6, 8		1	 4 009310 513008

kwb-Info

For larger holes in hard tiles.

Kwb has suitable diamond holesaws for porcelain and hard tiles for drilling wallplug holes, water and waste pipe holes, electrical boxes and sockets.

















You can find these products in our catalogue on page 132.



Specialised drill bits

Glass drills, carded



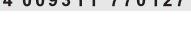

Art.-No.	Ø mm			Barcode
carded				
177003	3		6	
177004	4		6	
177005	5		6	
177006	6		6	
177007	7		6	
177008	8		6	
177010	10		1	
177012	12		1	

Glass drills, tungsten carbide tipped, plates specially and cross-ground, for all rotary and impact drills, chromated finish, for glass, porcelain, tiles to hardness 8, ceramics.



Glass drill set, 5-piece



Art.-No.	Ø mm			Barcode
177000	4, 5, 6, 8, 10		1	

Glass drills, tungsten carbide tipped, plates specially and cross-ground, for all rotary and impact drills, chromated finish, for glass, porcelain, tiles to hardness 8, ceramics.

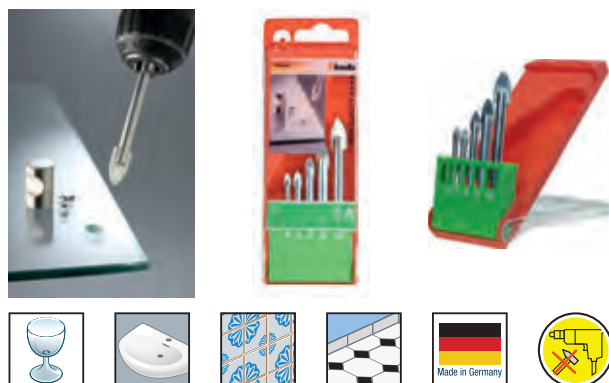

Circle Cutter, tungsten carbide tipped, continuously adjustable



Tungsten circle cutter, tungsten carbide tipped, cutting arm continuously adjustable from 20-90mm, shank diameter 9mm, for tiles, bricks, plaster, plastics.

Art.-No.	Ø mm			Barcode
178100	20 - 90		2	4 009311 781000



Circle Cutter, tungsten carbide tipped, with guard



Tungsten circle cutter, tungsten carbide tipped, cutting arm continuously adjustable from 20-90mm, shank diameter 9mm, for tiles, bricks, plaster, plastics.

Art.-No.	Ø mm			Barcode
178200	20 - 90 Safety model with plastic shield		1	4 009311 782007





WOOD DRILL BITS

Hardwood drill bits

Wood drill bits

Beam drill bits

Auger bits

Hinge sinker bits

Flat wood bits

Wood drill bits



The benefits of wood drill bits

- Wood drill bits for every type of wood and every job
- For drilling in softwoods and hardwoods
- For decking, interior woodwork, joinery or framework

Programme overview wood drill bits



FCE hardwood drill bits

★★★★★

With patented centre point for break-out free holes without burn marks and HSS-M2 spirals with TwinLand[®] flute design, for rapid chip removal and up to 6 times faster drilling in soft- and hardwoods, eg Banghirai etc..

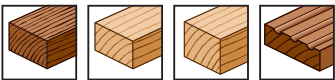

Page 60



HSS hardwood drill bits

★★★★★

HSS hardwood drill bits with adjustable countersink and counterbore, ideal for pre-drilling of hardwoods before laying decking and outdoor woodwork.

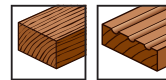

Page 60



2-Phase spiral lip-and-spur wood bits

★★★★★

With 2-phase spiral form for concentric running, giving precise drilling in soft- and hardwoods.

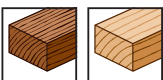

Page 61



Spiral beam wood drill bits, extra long

★★★★

In 250 mm and 400 mm lengths, especially for beams in construction work, for all rotary and impact drills with 13 mm chuck, for shuttering, hard- and softwoods, lightweight construction materials, plasterboard.

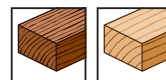

Page 64

Wood drill bits



Framework drills

★★★★★

In 400 mm and 600 mm lengths, for shuttering, interior woodwork, central heating installation, electrical work. In CrV and HSS material.



Page 64 - 65



Auger bits, 235 mm and 460 mm

★★★★★

Drill tip with pull-in point and cutting wings. Special point geometry for reduced frictional resistance, solid centre and low-friction spiral give accurate drilling with extra high chip removal.

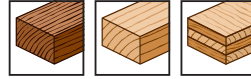

Page 66



Hinge sinker bits

★★★★★

For pre-drilling holes for concealed cupboard hinges in cabinet work.

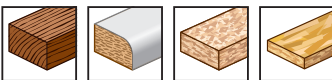

Page 67



Forstner bits

★★★★★

Precision drill bits for break-out free holes in hardwoods and softwoods. Also for large diameters.

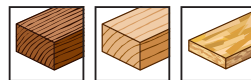

Page 68



Flat wood bits

★★★★★

With centre point and 2 cutting wings for precise drilling in soft- and hardwoods.



Page 69



Expansive wood bit

★★★★★

With centre point and two adjustable blades for precise drilling in soft- and hardwoods.

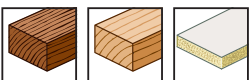







Page 70

kwb-Info

The colour-coding system for wood drill bit packaging

On the drill bit packaging, KWB sets out well-targeted end user information. The packaging attracts attention with a clear colour-coding system to indicate the correct drill for the relevant material with informative action photos.

-  **HARDWOOD DRILL BITS**
-  **SPIRAL LIP-AND-SPUR WOOD BITS**
-  **AUGER BITS**
-  **FLAT WOOD BITS**
-  **FRAMEWORK DRILLS**
-  **BEAM DRILL BITS**









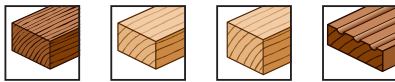











FCE hardwood drill with TwinLand® flute design, carded



FCE wood drill bits, HSS-M2, precision ground, with TwinLand® flute design, self colour, with patented centre point and two cutting wings, special grinding for break-out free hole edges without feathering, cylindrical shank, industrial quality, for Bangkirai, hardwood, softwood, up to 6 times faster drilling in hardwood.











Art.-No.		Ø mm			Barcode
carded					
511903	61	3		10	
511904	75	4		10	
511905	86	5		10	
511906	93	6		10	
511907	109	7		10	
511908	117	8		10	
511909	125	9		10	
511910	133	10		10	

HSS-M2 hardwood drills with adjustable counterbore and countersink, carded



Hardwood drill bit, HSS-M2, with adjustable counterbore and countersink, ball-bearing counterbore stops rotating when it grounds, preventing marking of the wood, 1/4" hexagon shank to ISO 1173, E 6.3, for Bangkirai, hardwood, softwood, ideal for pre-drilling of hardwoods when working on decking or garden furniture, with perfect bore and countersink depth on every fixing.



Art.-No.	Ø mm			Barcode
carded				
512004	4		1	
512005	5		1	
512006	6		1	

For dry wood when drilling

- Universally usable device for measuring damp in construction materials and wood
- Ideal applications include renovation work, assessing water damage and buying timber
- Large, easy to read LCD display
- Suitable for a wide variety of materials
- With LED to illuminate dark areas



kwb building materials and wood damp meter
Part.-No. 012100

Wood drill bits

Wood drill bits, carded



Art.-No.	∅ mm	Flute mm	Icon 1	Icon 2	Barcode
carded					
511463	3	cyl.	Icon 1	10	4 009315 114637
511464	4	cyl.	Icon 1	10	4 009315 114644
511465	5	cyl.	Icon 1	10	4 009315 114651
511466	6	cyl.	Icon 1	10	4 009315 114668
511467	7	cyl.	Icon 1	10	4 009315 114675
511468	8	cyl.	Icon 1	10	4 009315 114682
511470	10	cyl.	Icon 1	10	4 009315 114705
511472	12	8	Icon 1	5	4 009315 114729
511473	13	8	Icon 1	5	4 009315 114736
511474	14	10	Icon 1	5	4 009315 114743
511475	15	10	Icon 1	5	4 009315 114750
511476	16	10	Icon 1	5	4 009315 114767
511477	17	10	Icon 1	5	4 009315 114774

Wood drill bits, CrV steel, accurately formed, 2-phase spirals for concentric running, chemical black, ground spirals, with centre point and shoulder cutter, for accurate break-out free holes, round shank, industrial quality, for soft- and hardwoods.



Wood drill bit sets, CrV steel, 2-phase flutes, 5-, 7- and 8-piece



Art.-No.	∅ mm	Contents each pack	Icon 1	Icon 2	Barcode
514000	4, 5, 6, 8, 10	5	Icon 1	6	4 009315 140001
514100	3, 4, 5, 6, 7, 8, 9, 10	8	Icon 1	6	4 009315 141008
514200	3, 4, 5, 6, 8, 10, 1 countersink 90	7	Icon 1	6	4 009315 142005

Wood drill bits, CrV steel, accurately formed, 2-phase spirals for concentric running, chemical black, ground spirals, with centre point and shoulder cutter, for accurate break-out free holes, round shank, industrial quality, for soft- and hardwoods.









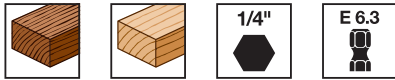





Wood drill bits with hexagon shaft 1/4", E6.3, carded



Wood drill bits, CrV steel, 1/4" hexagon shank to ISO 1173, E 6.3, accurately formed, chemical black, ground spirals, with centre point and 2 cutting wings, for accurate break-out free holes, for all cordless drivers and drills and bit holders with 1/4" hexagon drive to ISO 1173, for soft- and hardwoods.



Art.-No.			Ø mm			Barcode
carded						
513903	35	40	3		10	
513904	40	50	4		10	
513905	50	60	5		10	
513906	55	65	6		10	

Wood drill set, 5-piece



Wood drill bits, CrV steel, 1/4" hexagon shank to ISO 1173, E 6.3, accurately formed, chemical black, ground spirals, with centre point and 2 cutting wings, for accurate break-out free holes, for all cordless drivers and drills and bit holders with 1/4" hexagon drive to ISO 1173, for soft- and hardwoods.

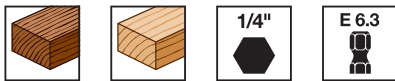

Art.-No.	Ø mm			Barcode
513900	3, 4, 5, 6, 8		6	

Wood drill bits

Wood drill with counterbore







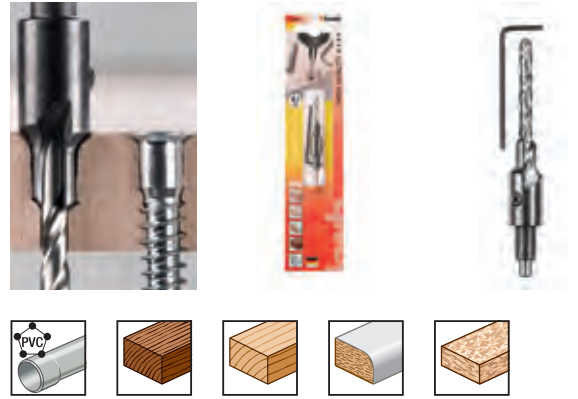





Art.-No.	Ø mm			Barcode
512604	4,5 + 7,0			

Wood drill bit, HSS-M2, spiral drill with carbon steel counterbore, for installing structural countersunk woodscrews, counterbores 4.5 and 7mm diameter, and countersinks 11mm, suitable for IKEA screws, for soft- and hardwoods, coated and uncoated boards, plastics.



Wood drill set with slip-on countersink and depth stop, 3-piece



Art.-No.	Ø mm			Barcode
513103	3		5	
513104	4		5	
513105	5		5	
513106	6		5	

Wood drill bit, CrV steel, with adjustable 5-flute carbon steel countersink and depth stop, cylindrical shank, for soft- and hardwoods.



kwb-Info

A safer job.

It's always a good idea to wear protective gloves when your hands could possibly be injured, for example in building work with sharp-edged objects etc.

For all types of work, a safe grip and wearer comfort are the prime requirements for the correct type of glove.

You can find all the relevant information in our **Personal Protection catalogue**, or on the Internet at **www.kwb.eu**.























Extra long wood drill for beams, 250 mm, wallet with inlay card



Wood drill bits, extra long, CrV steel, accurately formed, single spiral, chemical black, chamfer ground, with centre point and 2 cutting wings, for accurate break-out free holes in beams, industrial quality, for soft- and hardwoods.



















Art.-No.		Ø mm				Barcode
250mm, wallet with inlay card						
511806	250	6	cyl.		5	
511808	250	8	cyl.		5	
511810	250	10	cyl.		5	
511812	250	12	10		5	
511814	250	14	10		5	
511816	250	16	10		5	
511818	250	18	13		5	
511820	250	20	13		5	

Beam drill, wood drill, extra long, 400 mm, wallet with inlay card



Wood drill bits, extra long, CrV steel, accurately formed, single spiral, chemical black, chamfer ground, with centre point and 2 cutting wings, for accurate break-out free holes in beams, industrial quality, for soft- and hardwoods.























Art.-No.		Ø mm				Barcode
400mm, wallet with inlay card						
512810	400	10	cyl.		5	
512812	400	12	10		1	
512814	400	14	10		1	
512816	400	16	10		1	
512818	400	18	13		1	
512820	400	20	13		1	

Frame Work Drills, 400 mm wallet with inlay card



























Framework and installation drill bits, HSS steel, tip angle 118 deg. to DIN 7490, drill bit screwed and bonded to shaft, reducing the risk of breakage and giving better concentricity, no jamming in green wood, for all rotary and impact drills with 13mm chuck, for composite materials with steel or aluminium, profiles, shuttering, hard- and softwoods, lightweight boards and plasterboard.



Art.-No.		Ø mm				Barcode
400mm, wallet with inlay card						
043606	400	6	6		1	
043608	400	8	7		1	
043610	400	10	8		1	
043612	400	12	10		1	
043614	400	14	10		1	
043616	400	16	10		1	
043618	400	18	12		1	
043620	400	20	12		1	

Framework wood drill, 400 mm, wallet with inlay card







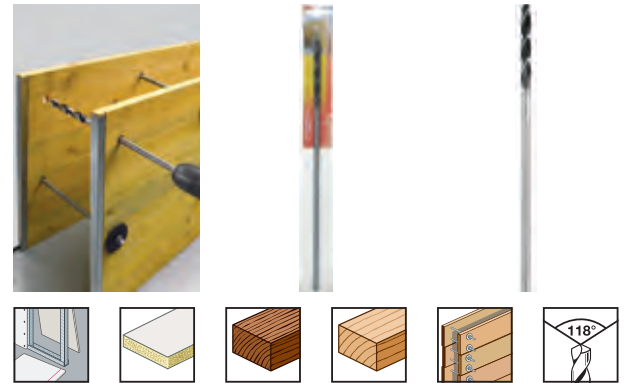

















Art.-No.		Ø mm				Barcode
400mm, wallet with inlay card						
043206	400	6	6		1	
043208	400	8	7		1	
043210	400	10	8		1	
043212	400	12	10		1	
043214	400	14	10		1	
043216	400	16	10		1	
043218	400	18	12		1	
043220	400	20	12		1	
043222	400	22	13		1	
043225	400	25	13		1	

Framework and installation drill bits, CrV steel, tip angle 118 deg., drill bit screwed and bonded to shaft, reducing the risk of breakage and giving better concentricity, no jamming in green wood, for all rotary and impact drills with 13mm chuck, for shuttering, hard- and softwoods, light-weight boards and plasterboard.



Framework wood drill, 600 mm, wallet with inlay card



Art.-No.		Ø mm				Barcode
600mm, wallet with inlay card						
043408	600	8	7		1	
043410	600	10	8		1	
043412	600	12	10		1	
043414	600	14	10		1	
043416	600	16	10		1	
043418	600	18	12		1	
043420	600	20	12		1	
043422	600	22	13		1	
043425	600	25	13		1	

Framework and installation drill bits, CrV steel, tip angle 118 deg., drill bit screwed and bonded to shaft, reducing the risk of breakage and giving better concentricity, no jamming in green wood, for all rotary and impact drills with 13mm chuck, for shuttering, hard- and softwoods, light-weight boards and plasterboard.

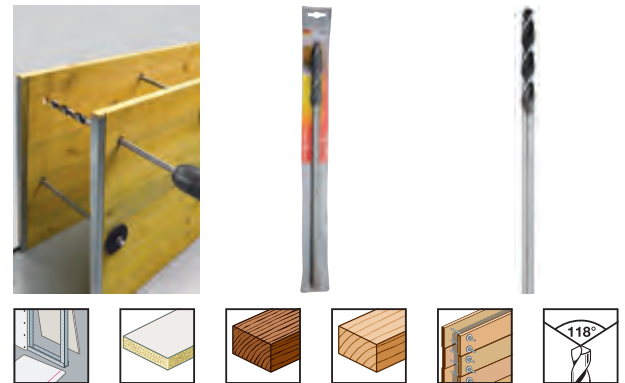







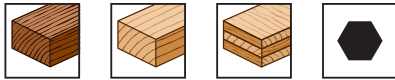
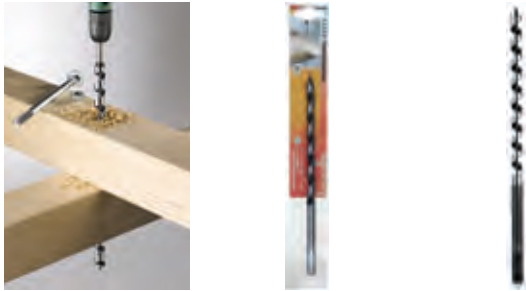























Auger bits, 235mm, wallet with inlay card



Auger bits, CrV steel, hexagon shank, precision ground, chemical blacked smoothly ground, tip with pull-in point for rapid drilling with less effort, precision ground cutting edges and wings, for accurate drilling in wooden beams and roof timbers, industrial quality for use in joinery, roofing and related trades.











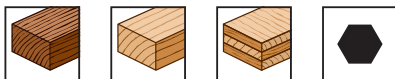























Art.-No.			Ø mm				Barcode
235mm, wallet with inlay card							
042206	160	235	6	○6		1	
042208	160	235	8	○6		1	
042210	160	235	10	○6		1	
042212	160	235	12	○6		1	
042214	160	235	14	○6		1	
042216	160	235	16	○10		1	
042218	160	235	18	○10		1	
042220	160	235	20	○10		1	
042222	160	235	22	○10		1	
042224	160	235	24	○10		1	
042226	160	235	26	○10		1	
042228	160	235	28	○10		1	
042230	160	235	30	○10		1	

Auger bits, 460mm, wallet with inlay card



Auger bits, CrV steel, hexagon shank, precision ground, chemical blacked smoothly ground, tip with pull-in point for rapid drilling with less effort, precision ground cutting edges and wings, for accurate drilling in wooden beams and roof timbers, industrial quality for use in joinery, roofing and related trades.



Art.-No.			Ø mm				Barcode
460mm, wallet with inlay card							
042406	390	460	6	○6		1	
042408	390	460	8	○8		1	
042410	390	460	10	○8		1	
042412	390	460	12	○10		1	
042414	390	460	14	○10		1	
042416	390	460	16	○10		1	
042418	390	460	18	○10		1	
042420	390	460	20	○10		1	
042422	390	460	22	○10		1	
042424	390	460	24	○10		1	
042426	390	460	26	○10		1	
042428	390	460	28	○10		1	
042430	390	460	30	○10		1	

Hinge Sinker Bit, TCT



Art.-No.	∅ mm	T mm			Barcode
705930	35	8		1	4 009317 059301

Hinge sinker bit, tungsten carbide tipped, for pre-drilling holes for concealed cupboard hinges, for hardwoods, laminates, chipboard, block-board.

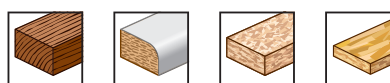

Hinge Sinker Bit



Art.-No.	∅ mm	T mm			Barcode
705510	26	8		1	4 009317 055105
705520	30	8		1	4 009317 055204
705530	35	8		1	4 009317 055303

Hinge sinker bit, special steel, for pre-drilling holes for concealed cupboard hinges, for hard- and softwoods, blockboard.

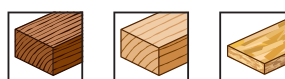

Plug cutter set, 3-piece



Art.-No.	mm	∅ mm	T mm			Barcode
706900	17	10, 12, 16	8		2	4 009317 069003

Plug cutters, precision ground cutting edges, for making tight-fitting cylindrical plugs, extra long body with open sides allow the cutting of long plugs with easy removal, especially suitable for carpentry, joinery and kitchen fitting, for softwood.









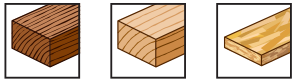























Forstner wood bits, carded



Forstner bits, to DIN 7483 G, for wood, high quality special steel, cutting edges ground and sharpened, 2 end cutters and two edge cutters, centre point, self colour with black finish flutes, break-out free hole edges, for all rotary and impact drills with 10/13mm chucks, for hard- and soft-woods, veneered wood, blockboard. Splinter-free holes even with large diameters.







Art.-No.	Ø mm	ℓ mm			Barcode
carded					
706010	10	8		1	
706012	12	8		1	
706015	15	8		1	
706016	16	8		1	
706018	18	8		1	
706020	20	8		1	
706022	22	8		1	
706025	25	8		1	
706026	26	8		1	
706030	30	8		1	
706035	35	10		1	
706040	40	10		1	
706045	45	10		1	
706050	50	10		1	

Forstner bit set, 5 piece

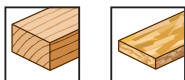

Forstner bits, to DIN 7483 G, for wood, high quality special steel, cutting edges ground and sharpened, 2 end cutters and two edge cutters, centre point, self colour with black finish flutes, break-out free hole edges, for all rotary and impact drills with 10/13mm chucks, for hard- and soft-woods, veneered wood, blockboard. Splinter-free holes even with large diameters.



















































Art.-No.	Ø mm	Contents each pack			Barcode
706000	15, 20, 25, 30, 35	5		1	

Wood drill bits

PROFI flat wood bits, carded



Art.-No.	∅ mm	T mm			Barcode
carded					
512406	6	6		5	
512408	8	6		5	
512410	10	6		5	
512412	12	6		5	
512413	13	6		5	
512414	14	6		5	
512416	16	6		5	
512417	17	6		5	
512418	18	6		5	
512419	19	6		5	
512420	20	6		5	
512422	22	6		1	
512424	24	6		1	
512425	25	6		1	
512426	26	6		1	
512428	28	6		1	
512430	30	6		1	
512432	32	6		1	
512434	34	6		1	
512435	35	6		1	
512436	36	6		1	
512438	38	6		1	
512440	40	6		1	

Flat wood bit, for woodworking, 1/4" hexagon shank to ISO 1173, E 6.3, with centre point and two cutting wings, special cutting geometry, precision ground, for safe and accurate drilling, grey colour, sandblasted, precise holes with low effort, for soft- and hardwoods, lightweight building materials.

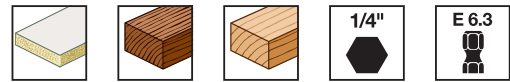

kwb-Info

For smooth surfaces and edges

Break-out and splinters after drilling can easily be removed with the kwb cork hand sanding block. This product made from natural cork is the classic hand sanding tool and is suitable for use with all types of sandpaper. Especially for sanding small areas.





For more abrasives see the relevant section from page 151 of our catalogue.



Flat wood bit set, 7-piece



Flat wood bit, for woodworking, 1/4" hexagon shank to ISO 1173, E 6.3, with centre point and two cutting wings, special cutting geometry, precision ground, for safe and accurate drilling, grey colour, sandblasted, precise holes with low effort, for soft- and hardwoods, lightweight building materials.



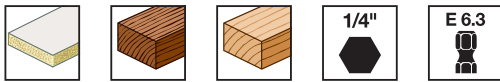



Art.-No.	Ø mm	Contents each pack			Barcode
512250	10, 12, 16, 18, 20, 22, 24	7		1	 4 0093 15 122502



Extension for flat wood bits



Flat wood bit extension, for 1/4" hexagon shanks to ISO 1173, E 6.3. Phosphated finish.

Art.-No.	Drive	 mm			Barcode
512400	6 mm	300		2	 4 0093 15 124001
512450	1/4" E and 6.3	300		1	 4 0093 15 124506



Expansive wood bit



Expanding wood bit, cylindrical shaft, with centre point, adjustable, with two cutting blades, for diameters 15-25mm and 25-45mm. Grey finish, sandblasted, for soft- and hardwoods, lightweight building materials.

Art.-No.	 mm			Barcode
175440	15 - 45		1	 4 0093 11 754400

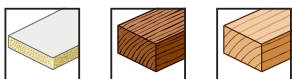

IMPAKTOR
Diamond

SCREWDRIVER BITS

IMPAKTOR bits

Diamond bits

Titanium bits

Iso-Temp bits

Screwdriver bits

POWER BOX bit boxes

Screwdriver bits



Benefits of bits

- High quality bits for every application
- From specialised bits for extreme applications through to standard bits to suit every need
- Accurate profiles, correctly hardened
- kwb Handy Bit-Box, patented, practical, handy and compact, can also be used as hand screwdriver

Programme overview screwdriver bits



IMPAKTOR bits

★★★★★

The strongest bits for the most extreme demands, especially suitable for use with popular cordless impact drivers.



Page 74 - 75



DIAMOND bits

★★★★★

Reduce cam-out and pressure on the screw, for fatigue-free working.



Page 79 - 80



TITAN bits

★★★★★

High quality surface coating for low friction and high wear resistance even with heavy use.



Page 81 - 83



ISO-TEMP Bits

★★★★★

With ACR ribbing, which reduces the tendency for the bit to „cam out“, requiring less working pressure. Fatigue-free working. Special bit for use with very hard screws, reducing risk of breakage.



Page 84 - 85

Application guide

Plain DIN 2380	Phillips / Cross DIN 8764	Pozidriv DIN 8764	Torx DIN EN ISO 10664	Tamper Torx DIN EN ISO 10664	Hexagon DIN 2351



Stainless steel bits

★★★★★

For use with stainless steel bits, avoids leaving rust marks on the screw through surface damage. Ideal for all outdoor screwdriving, e.g. decking.



Page 86



Standard bits

★★★★★

For all standard screwdriving jobs.



Page 87 - 89



Standard bits, other patterns

★★★★★

For all standard screwdriving jobs.



Page 90 - 93



Bit boxes

★★★★★

For individual use.

Page 94 - 98

... always the appropriate accessories for your machine!

Impaktor bits from kwb resist all tough screwdriving conditions and impact screwdriver machines

Conventional bits are not made for extreme requirements and will quickly wear during use.

All **kwb Impaktor bits** have diamond particles on the bit tip and make it cling to the screw and reduce the cam-out forces which can make the screw slip out. Therefore, the contact pressure for machine screwdriving is reduced. Also effective with TORX[®].



kwb Impaktor bits for all impact screwdrivers in the established sizes 25 mm and 50 mm

Depending on the output, **kwb Impaktor bits** have up to 5 times longer durability compared to conventional or torsion bits. The **kwb Impaktor bits** are particularly suitable for use with customary impact screw drivers.

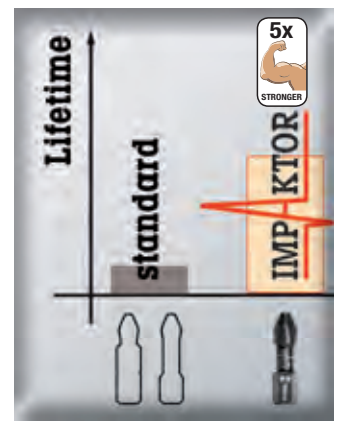

Durability compared to conventional bits

Impaktor bits for extreme requirements, 25 and 50 mm



Due to optimal utilisation of the material properties and optimally adjusted geometries, the Impaktor technology provides for above-average durability with under extreme requirements; particularly suitable for use with customary impact screwdrivers; the rough diamond coating reduces cam-out due to increased friction resistance.

Part-No.	Contents	📦	📦	EAN
105502	Impaktor bit PH 2 x 25 mm SB	📦	5	4 0 093 11 055026
105503	Impaktor bit PH 3 x 25 mm SB	📦	5	4 0 093 11 055033
105552	Impaktor bit PH 2 x 50 mm SB	📦	5	4 0 093 11 055521
105553	Impaktor bit PH 3 x 50 mm SB	📦	5	4 0 093 11 055538
105602	Impaktor bit PZ 2 x 25 mm SB	📦	5	4 0 093 11 056023
105603	Impaktor bit PZ 3 x 25 mm SB	📦	5	4 0 093 11 056030
105652	Impaktor bit PZ 2 x 50 mm SB	📦	5	4 0 093 11 056528
105653	Impaktor bit PZ 3 x 50 mm SB	📦	5	4 0 093 11 056535
105720	Impaktor bit TX 20 x 25 mm SB	📦	5	4 0 093 11 057204
105725	Impaktor bit TX 25 x 25 mm SB	📦	5	4 0 093 11 057259
105730	Impaktor bit TX 30 x 25 mm SB	📦	5	4 0 093 11 057303
105740	Impaktor bit TX 40 x 25 mm SB	📦	5	4 0 093 11 057402

Impaktor bits / Impaktor bit holder

Impaktor bit holder by kwb with ring magnet and spring clip for all impact screwdrivers



Due to optimal utilisation of the material properties and optimally adjusted geometries (two coupled torsion zones which are consecutively acting), the **kwb Impaktor technology** provides for above-average durability even under tough conditions.

The Impaktor holder with ring magnet additionally holds long and heavy screws firmly with secure grip. Rapid and secure screw placement prevents angular positioning and destruction of the screw. Applied mainly with manual machine screwdriving. Suitable for bits with 1/4" C 6.3.



Over-average durability by extreme utilisation of material properties in connection with geometries especially adjusted to the extreme requirements as well as their manufacturing processes.

The **kwb Impaktor bit series** is manufactured with an optimally adjusted combination of geometric design, hardness,

manufacturing process and hardening and tempering for the particular output torque and thus for the individual screwdriving case.

The **kwb Impaktor bit holder** is particularly suitable for use with customary impact screw drivers.



The **Impaktor bit holder** can absorb extreme peak pulse power and due to the **TriTorsion system**, it individually reacts towards the output of the impact screwdrivers used.



Depending on the output, **kwb Impaktor bits** with Impaktor bit holder have up to 10 times longer durability compared to conventional or torsion bits.

TriTorsion

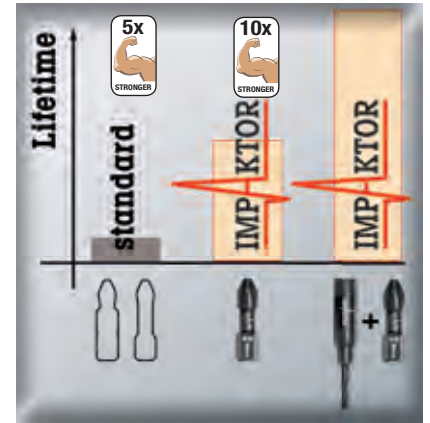

Durability compared to conventional bits

Impaktor bit holder



Impaktor Bit Holder, 1/4" hexagon drive to ISO 1173, with permanent and ring magnet, spring clip, quick release function, one hand operation, bit ejection simply by pulling back the metal sleeve, hexagon shank 1/4" drive to ISO 1173, E 6.3, especially suitable for use with leading impact drivers.



Part-No.	Contents			EAN
100500	Impaktor bit holder		5	

Bit holder, stainless steel body



Bit holder, 1/4" hexagon drive to ISO 1173, with permanent magnet and spring clip, 1/4" hexagon shank to ISO 1173, E 6.3.



Art.-No.	Drive	Length	Shank			Barcode
100100	1/4" ◻	75 mm	1/4" ● E 6.3		5	4 009311 001009
100800	1/4" ◻	58 mm	1/4" ● E 6.3		5	4 009311 008008
100811	1/4" ◻	58 mm	1/4" ● E 6.3		5	4 009311 008114

Bit holder, brass body

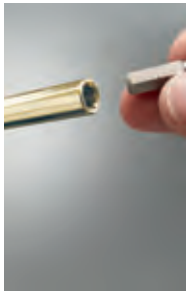

Bit holder, 1/4" hexagon drive to ISO 1173, with permanent magnet and spring clip, 1/4" hexagon shank to ISO 1173, E 6.3.



Art.-No.	Drive	Length	Shank			Barcode
100120	1/4" ◻	75 mm	1/4" ● E 6.3		5	4 009311 001207
100121	1/4" ◻	75 mm	1/4" ● E 6.3		5	4 009311 001214

Bit holder, stainless steel body, SDS shank



Bit holder, 1/4" hexagon drive to ISO 1173, with permanent magnet and spring clip, SDS Plus shank.







Art.-No.	Drive	Length	Shank			Barcode
100600	1/4" ◻	75 mm	SDS Plus		1	4 009311 006004

Screwdriver bits

Quick-release bit holder



Quick-release bit holder, 1/4" hexagon drive to ISO 1173, with permanent magnet, spring clip, quick-release function, one hand operation, bit ejects by simply pulling back the metal sleeve, 1/4" hexagon shank to ISO 1173, E 6.3.

Art.-No.	Drive	Length	Shank			Barcode
100300	1/4" ○	51 mm	1/4" ● E 6.3		1	



Automatic quick-release bit holder



Automatic quick-release bit holder, one touch, 1/4" hexagon shank to ISO 1173, with permanent magnet, spring clip, quick-release function, one hand operation, bit release by pressing the eject button, hexagon shank 1/4" to ISO 1173, E6.3.







Art.-No.	Drive	Length	Shank			Barcode
100400	1/4" ○	65 mm	1/4" ● E 6.3		6	



Quick-release bit holder



Quick-release bit holder, extra long, 1/4" hexagon fitting to ISO 1173, with permanent magnet, spring clip, quick-release function, one hand operation, bit ejects by simply pulling back the metal sleeve, 1/4" hexagon shank to ISO 1173, E 6.3.

Art.-No.	Drive	Length	Shank			Barcode
100715	1/4" ○	150 mm	1/4" ● E 6.3		6	
100730	1/4" ○	300 mm	1/4" ● E 6.3		6	



... always the appropriate accessories for your machine!

90° angle screwdriving and drilling attachment



With this 90 degree angle attachment with its ball-bearing spindle and head only 32mm deep you can drill and screwdrive in the narrowest and most inaccessible situations. Quick, easy bit changeover of screwdriver or drill bits with 1/4" hexagon shank C 6.3 or E 6.3. With the contoured handgrip you have a secure grip and can apply the right force while drilling and screwdriving in difficult to access areas. For use with all stand-ard cordless or mains drills.

Art.-No.	Drive	Length	Shank			Barcode
118400	1/4"	15,5 mm	1/4" E 6.3		1	4 009311 184009



Angle screwdriver attachment











Angle screwdriver attachment, 1/4" hexagon drive to ISO 1173, 90 deg. Angle head, quick and simple changeover between 1/4" hex shank bits or drills, secure control of screwdriving and drilling in very inaccessible areas, 1/4" hexagon shank, fits all standard cordless screwdrivers or any drill.

Art.-No.	Drive			Barcode
118100	1/4"		6	4 009311 181008









Diamond particle coated screwdriver bits











Art.-No.		Size			Barcode
⊕ Cross slot DIN 5260 / Phillips, carded					
103601	25	No.1		5	
103602	25	No. 2		5	
103603	25	No.3		5	

Diamond coated screwdriver bits, 1/4" hexagon drive to ISO 1173, C 6.3, diamond coating bites into the screw surface and reduces the tendency to „cam out“ of the screw as well as operator pressure required, giving fatigue-free working.









Art.-No.		Size			Barcode
⊕ Phillips / cross slot DIN 8764, bulk					
103611	25	No.1		Z5	
103612	25	No. 2		Z5	
103613	25	No.3		Z5	



Art.-No.		Size			Barcode
⊕ Pozidriv DIN 8764, carded					
103701	25	No.1		5	
103702	25	No. 2		5	
103703	25	No.3		5	

























Art.-No.		Size			Barcode
⊕ Pozidriv DIN 8764, bulk					
103711	25	No.1		Z5	
103712	25	No. 2		Z5	
103713	25	No.3		Z5	



Diamond particle coated screwdriver bits







Art.-No.		Size			Barcode
⊕ TORX® DIN EN ISO 10664, carded					
103810	25	T 10		5	
103815	25	T 15		5	
103820	25	T 20		5	
103825	25	T 25		5	
103830	25	T 30		5	
103840	25	T 40		5	

Art.-No.		Size			Barcode
⊕ TORX® DIN EN ISO 10664, bulk					
103860	25	T 10		Z10	
103865	25	T 15		Z10	
103875	25	T 25		Z10	
103880	25	T 30		Z10	
103890	25	T 40		Z10	

Handy Bit Box Diamond, 7-piece



Handy Bit Box diamond coated, 1/4" hexagon drive to ISO 1173, C 6.3, diamond particle coating bites into the screw surface to prevent „cam-out“ and reduce required pressure. Bit holder with permanent magnet, spring clip, 1/4" hexagon shaft to ISO 1173, E 6.3, patented bit box also can be used as hand screwdriver.









Art.-No.	Contents			Barcode
155300	7-piece ⊕ No. 1, 2, 3 / ⊕ No. 1, 2, 3 / Bitholder 1/4" C 6.3 / 1/4" E 6.3		6	



Screwdriver bits







Screwdriver bits, titanium nitrided

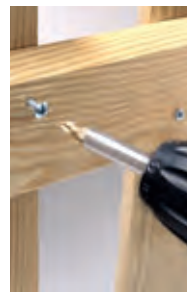









Art.-No.		Contents	Size			Barcode
⊕ Cross slot / Phillips DIN 5260, carded						
101501	25	1	No.1		10	
101502	25	1	No. 2		10	
101503	25	1	No.3		10	

Screwdriver bits Titanium nitrided, 1/4" hexagon drive to ISO 1173, C 6.3, extra hard low-friction surface, long working life, hard-wearing.







Art.-No.		Size			Barcode
⊕ Cross slot / Phillips DIN 5260, bulk					
101511	25	No.1		Z10	
101512	25	No. 2		Z10	
101513	25	No.3		Z10	









Art.-No.		Contents	Size			Barcode
⊕ Pozidriv DIN 8764, carded						
101601	25	1	No.1		10	
101602	25	1	No. 2		10	
101603	25	1	No.3		10	



Art.-No.		Contents	Size			Barcode
⊕ Pozidriv DIN 8764, trade pack, 10 pcs.						
101662	25	10	No. 2		1	



















Art.-No.		Size			Barcode
⊕ Pozidriv DIN 8764, bulk					
101611	25	No.1		Z10	
101612	25	No. 2		Z10	
101613	25	No.3		Z10	









... always the appropriate accessories for your machine!

Screwdriver bits, titanium nitrided

















Art.-No.		Contents	Size			Barcode
TORX® DIN EN ISO 10664, carded						
101710	25	1	T 10		10	
101715	25	1	T 15		10	
101720	25	1	T 20		10	
101725	25	1	T 25		10	
101727	25	1	T 27		10	
101730	25	1	T 30		10	
101740	25	1	T 40		10	



Art.-No.		Contents	Size			Barcode
TORX® DIN EN ISO 10664, trade pack, 10 pcs.						
101793	25	10	T 20		1	
101794	25	10	T 25		1	











Art.-No.		Size			Barcode
TORX® DIN EN ISO 10664, bulk					
101760	25	T 10		Z10	
101765	25	T 15		Z10	
101770	25	T 20		Z10	
101775	25	T 25		Z10	
101780	25	T 30		Z10	
101790	25	T 40		Z10	

Handy Bit Box, titanium nitrided, 7-piece







Handy Bit Box Titanium nitrided, 1/4" hexagon drive to ISO 1173, C 6.3, extra hard low-friction surface, long working life, hard-wearing. Bit holder with permanent magnet, spring clip, 1/4" hexagon shaft to ISO 1173, E 6.3, patented bit box also can be used as hand screwdriver.



Art.-No.	Contents			Barcode
154100	7-piece \ominus 5, 7 mm / \oplus No. 1, 2 / \oplus No. 1, 2 / Bit holder		6	
154200	T10, 15, 20, 25, 30, 40 / Bit holder		6	
154300	7-piece \oplus No.1 ,2, 3 / \oplus No. 1, 2, 3 / Bit holder		6	

Handy Bit Box, Tamper-proof Torx, titanium nitrided, 7-piece



Art.-No.	Contents			Barcode
154500	T10, 15, 20, 25, 30, 40 / Bit holder		6	 4 009311 545008

Handy Bit Box Titanium nitrided, 1/4" hexagon drive to ISO 1173, C 6.3, extra hard low-friction surface, long working life, hard-wearing. Bit holder with permanent magnet, spring clip, 1/4" hexagon shaft to ISO 1173, E 6.3, patented bit box also can be used as hand screwdriver.



kwb-Info

kwb's patented Handy Bit Box, which also acts as a hand screwdriver.

The small, practical Handy Bit Box fits in any pocket and comes quickly to the rescue whenever a small screwdriving job crops up.

Simply plug the bit holder provided into the end of the box and insert a suitable bit and you're ready to go.

The boxes are available containing diamond, titanium, Iso-Temp, stainless steel and standard bits.











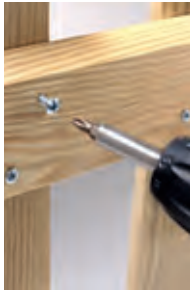

Exclusive to kwb





Screwdriver bits, ISO-TEMP

















ISO-TEMP screwdriver bits, 1/4" hexagon drive to ISO 1173, C6.3, high durability, special bits for use with hard screws, specially hardened to reduce risk of breakage, ACR point, ribbed to reduce the tendency to „cam-out“ of the screw, and to reduce the working pressure.



Art.-No.		Contents	Size			Barcode
⊕ Cross slot DIN 5260 / Phillips / carded						
104201	25	1	No.1		10	
104202	25	1	No. 2		10	
104203	25	1	No.3		10	

Art.-No.		Size			Barcode
⊕ Cross slot DIN 5260 / Phillips / bulk					
104211	25	No.1		Z10	
104212	25	No. 2		Z10	







Art.-No.		Contents	Size			Barcode
⊕ Pozidriv DIN 8764, carded						
104301	25	1	No.1		10	
104302	25	1	No. 2		10	
104303	25	1	No.3		10	

Art.-No.		Size			Barcode
⊕ Pozidriv DIN 8764, bulk					
104312	25	No. 2		Z10	
104313	25	No.3		Z10	

Screwdriver bits

Handy Bit Box ISO-TEMP, 7-piece



Art.-No.	Contents			Barcode
153100	7-piece ⊖ 5, 6 mm / ⊕ No.1, 2 / ⊕ No. 1, 2 / Bitholder		6	 4 009311 531001
153300	7-piece ⊕ No.1 ,2, 3 / ⊕ No. 1, 2, 3 / Bit holder		6	 4 009311 533005

Handy Bit Box diamond coated, 1/4" hexagon drive to ISO 1173, C 6.3, very hard-wearing, special bits for use with hard screws, specially hardened to reduce the risk of breakage, ACR tip, the ribs on the tip help to prevent „cam-out“ and reduce required pressure. Bit holder with permanent magnet, spring clip, 1/4" hexagon shaft to ISO 1173, E 6.3, patented bit box also can be used as hand screwdriver.



kwb-Info

Convenient storage for all individual screwdriver bits

All kwb individual screwdriver bits are supplied in a convenient storage box.

The key feature of these is:

All the individual boxes can be clipped together in a line, so all the individual bits are quickly to hand and safely stored.

Now when you put odd screwdriver bits in your tool box, they won't get lost.

Exclusive to kwb











Screwdriver bits, stainless steel











Screwdriver bits stainless steel, 1/4" hexagon drive to ISO 1173. C6.3, for driving stainless steel screws to prevent rust marks from surface damage, ideal for all outdoor screwdriving, eg decking, pergolas, benches etc.



Art.-No.		Size			Barcode
⊕ Pozidriv DIN 8764, carded					
104801	25	No.1		5	
104802	25	No. 2		5	
104803	25	No.3		5	







Art.-No.		Size			Barcode
⊕ TORX® DIN EN SIO 10664, carded					
104915	25	T 15		5	
104920	25	T 20		5	
104925	25	T 25		5	

Handy Bit Box, stainless steel, 7-piece



Handy Bit Box stainless steel, 1/4" hexagon drive to ISO 1173, C 6.3 for screwdriving with stainless steel screws to prevent rust spots from surface damage, ideal for all outdoor screwdriving, eg decking, pergolas, benches etc. Bit holder with permanent magnet, spring clip, 1/4" hexagon shaft to ISO 1173, E 6.3, patented bit box also can be used as hand screwdriver.



















Art.-No.	Contents			Barcode
156400	Magnetic bit holder / ⊕ No. 1, 2 / ⊕ No. 1, 2 / ⊕ T 20, T 25		6	

Screwdriver bits

Screwdriver bits STANDARD











Art.-No.		Contents	Size			Barcode
⊕ Cross slot / Phillips DIN 5260, carded						
101201	25	1	No.1		10	
101202	25	1	No. 2		10	
101203	25	1	No.3		10	
102201	25	3	No.1		10	
102202	25	3	No. 2		10	
102203	25	3	No.3		10	
106000	25	⊕ Phillips / cross slot DIN8764 , No.1,2,3	No.1,2,3		5	

Screwdriver bits STANDARD, industrial quality, 1/4" hexagon drive to ISO 1173, C 6.3, hard-wearing, for all standard screwdriving.















Art.-No.		Contents	Size			Barcode
⊕ Cross slot / Phillips DIN 5260, trade pack, 10 pcs.						
101262	25	10	No. 2		1	



Art.-No.		Size			Barcode
⊕ Cross slot / Phillips DIN 5260, bulk					
101211	25	No.1		Z10	
101212	25	No. 2		Z10	
101213	25	No.3		Z10	









Art.-No.		Contents	Size			Barcode
⊕ Pozidriv / carded						
101301	25	1	No.1		10	
101302	25	1	No. 2		10	
101303	25	1	No.3		10	
101304	32	1	No.4		10	
102301	25	3	No.1		10	
102302	25	3	No. 2		10	
102303	25	3	No.3		10	
106100	25	⊕ Pozidriv DIN 8764, No.1,2,3	No.1,2,3		5	









Screwdriver bits STANDARD















Art.-No.		Contents	Size			Barcode
⊕ Pozidriv DIN 8764, trade pack, 10 pcs.						
101362	25	10	No. 2		1	 4 009311 013620
101363	25	10	No.3		1	 4 009311 013637



























Art.-No.		Size			Barcode
⊕ Pozidriv / bulk					
101311	25	No.1		Z10	 4 009311 013118
101312	25	No. 2		Z10	 4 009311 013125
101313	25	No.3		Z10	 4 009311 013132
101314	32	No.4		Z10	 4 009311 013149



Art.-No.		Contents	Size			Barcode
Hexagon, carded						
101002	25	1	2,5		5	 4 009311 010025
101003	25	1	3		5	 4 009311 010032
101004	25	1	4		5	 4 009311 010049
101005	25	1	5		5	 4 009311 010056
101006	25	1	6		5	 4 009311 010063











Art.-No.		Contents	Size			Barcode
⊕ TORX® DIN EN ISO 10664, carded						
101806	25	1	T 6		5	 4 009311 018069
101807	25	1	T 7		5	 4 009311 018076
101808	25	1	T 8		5	 4 009311 018083
101809	25	1	T 9		5	 4 009311 018090
101810	25	1	T 10		5	 4 009311 018106
101815	25	1	T 15		5	 4 009311 018151
101820	25	1	T 20		5	 4 009311 018205
101825	25	1	T 25		5	 4 009311 018250
101827	25	1	T 27		5	 4 009311 018274
101830	25	1	T 30		5	 4 009311 018304
101840	25	1	T 40		5	 4 009311 018403











Screwdriver bits

Screwdriver bits STANDARD



Art.-No.		Contents	Size			Barcode
TORX® DIN EN ISO 10664, trade pack, 10 pcs.						
101892	25	10	T 15		1	
101893	25	10	T 20		1	
101894	25	10	T 25		1	







Art.-No.		Size			Barcode
TORX® DIN EN ISO 10664, bulk					
101859	25	T 9		Z5	
101860	25	T 10		Z5	
101865	25	T 15		Z5	
101870	25	T 20		Z5	
101875	25	T 25		Z5	
101880	25	T 30		Z5	
101890	25	T 40		Z5	



Handy Bit Box STANDARD, 7-piece









Art.-No.	Contents			Barcode
152500	10, 15, 20, 25, 30, 40 / Bit holder		6	

Handy Bit Box STANDARD, 1/4" hexagon drive to ISO 1173, C 6.3, hard-wearing, for all standard screwdriving. Bit holder with permanent magnet, spring clip, 1/4" hexagon shaft to ISO 1173, E 6.3, patented bit box also can be used as hand screwdriver.



PROFI Power Bit Box STANDARD, 31-piece



Art.-No.	Contents			Barcode
162200	⊖ 2 x Nr. 1, 4 x Nr. 2, ⊕ 2 x Nr. 1, 4 x Nr. 2, ⊕ 3 x 10, 15, 20, 5 x 25, 2 x 30, 40		1	
162300	⊕ 3 x Nr. 1, 10 x Nr. 2, 2 x Nr. 3 / ⊕ 3 x Nr. 1, 10 x Nr. 2, 2 x Nr. 3		1	

Power Bit-Box STANDARD, industrial quality, 1/4" hexagon drive to ISO 1173, C 6.3, hard-wearing, for all standard screwdriving. Quick-release bit holder, 1/4" shank to ISO 1173, E 6.3, patented bit box.











Screwdriver bits STANDARD











Screwdriver bits STANDARD, industrial quality, 1/4" hexagon drive to ISO 1173, C 6.3, hard-wearing, for all standard screwdriving.

















Art.-No.		Contents	Size			Barcode
⊕ Cross slot DIN 5260 / Phillips / carded						
102901	50	1	No.1		5	
102902	50	1	No. 2		5	
102903	50	1	No.3		5	







Art.-No.		Contents	Size			Barcode
⊕ Pozidriv DIN 8764, carded						
103001	50	1	No.1		5	
103002	50	1	No. 2		5	
103003	50	1	No.3		5	



Art.-No.		Contents	Size			Barcode
⊗ TORX® DIN EN ISO 10664, carded						
103110	50	1	T 10		5	
103115	50	1	T 15		5	
103120	50	1	T 20		5	
103125	50	1	T 25		5	
103130	50	1	T 30		5	
103140	50	1	T 40		5	



Art.-No.	Contents			Barcode
⊕ Pozidriv DIN 8764 + ⊕ Corss slot/Phillips DIN 8764, carded				
108602	No.2 x No.2		5	

Screwdriver bits

Socket set with adaptor, 5-piece



Socket set, chrome vanadium, polished chrome finish, with STANDARD adaptor, 1/4" square drive to 1/4" hexagon drive to ISO 1173, E 6.3.





Art.-No.	Contents			Barcode
105100	● 7,8,10,13 mm, Adapter 50 mm		5	



Adaptor set for sockets, 2-piece



Adaptor set for sockets, chrome vanadium, STANDARD, for all standard sockets with 1/4" square drive. Adaptor 30mm, 1/4" square drive x 1/4" hexagon to ISO 1173, C 6.3. Adaptor 50mm, 1/4" square drive x 1/4" hexagon to ISO 1173, C 6.3.

Art.-No.	Contents			Barcode
105200	● 1/4" x ■ 1/4" 30 mm / ● 1/4" x ■ 1/4" 50 mm		5	



Adaptor set for sockets, 3-piece set



Adaptor set for sockets, chrome vanadium, polished chrome finish, for all standard sockets with 1/4", 3/8" & 1/2" square drive, to 1/4" hexagon drive to ISO 1173, E 6.3.

Art.-No.	Contents			Barcode
105300	● 1/4" x ■ 1/4" / ● 1/4" x ■ 3/8" / ● 1/4" x ■ 1/2"		6	



ECONOMY Double-ended Bit Set, 1/4", 6-piece in clip



Double-ended bit set, 65mm, STANDARD, industrial quality, 1/4" hexagon drive to ISO 1173, E 6.3, hard-wearing, for all standard screwdriving.

Art.-No.		Contents			Barcode
110900	65	⊕ Cross slot/Phillips x ⊖ Slotted No. 1 x 4, No. 2 x 5, No. 3 x 6 mm ⊕ Pozidriv x ● hexagon		10	4 009311 109002



ECONOMY Bit Set, 1/4", long, 6-piece in clip



Bit set, long pattern, 75mm, STANDARD, industrial quality, 1/4" hexagon drive to ISO 1173, E 6.3, hard-wearing, for all standard screwdriving.

Art.-No.		Contents			Barcode
111100	75	⊕ Cross slot/Phillips Nr. 1, 2, 3 / ⊕ Pozidriv Nr. 1, 2, 3		10	4 009311 111005



ECONOMY Bit Set, 1/4", extra long, 4-piece in clip



Bit set, extra long pattern, 130mm, STANDARD, industrial quality, 1/4" hexagon drive to ISO 1173, E 6.3, hard-wearing, for all standard screwdriving.

Art.-No.		Contents			Barcode
111500	130	⊕ Cross slot/Phillips Nr. 2 / ⊕ Pozidriv No. 1, 2, 3		10	4 009311 115003



Screw eye/ wing nut driver bit, 2 pack



Screw eye/ wingnut driver, STANDARD, industrial quality, 1/4" hexagon drive, high durability, for all dresser hooks, wing nuts, screw hooks and eyes up to 4mm







Art.-No.	Drive	Length	Shank			Barcode
102000	1/4" ○	20 mm	1/4" ● C 6.3			4 009311 020000

Screwdriver bits

Screwdriver bits with depth stop STANDARD



Bits with depth stop, STANDARD, 1/4" drive to ISO1173, C6.3, high durability, for fixing lightweight building materials eg plasterboard, prevent overdriving of screws.





Art.-No.	Contents			Barcode
104500	⊕ Phillips / cross slot DIN 8764 No.2		2	
104600	⊕ Pozidriv DIN 8764 No.2		2	



Bit Dispenser STANDARD, 9-piece



Bit dispenser STANDARD, 1/4" hexagon drive to ISO 1173, C 6.3, hard-wearing, for all standard screwdriving, bit holder with permanent magnet, spring clip, 1/4" hexagon shank to ISO 1173, E 6.3, practical drawer box.





Art.-No.		Contents			Barcode
113900	25, 50	9-piece ⊖ 4.5, 7mm / ⊕ No.1, 2 / ⊕ No.1, 2 / ⊕ No.2 / Bit holder 1/4" C 6.3/ 1/4" E 6.3		10	



Precision bit-/socket-set STANDARD, 40-piece



Precision bit and socket set STANDARD, bits with 4mm hexagon drive, with colour coded rings, includes microbits for working on glasses, mobile phones, cameras, MP3-players, laptops, remote controls, colour-coded sockets, flexible extension, removal handle. 4mm hexagon drive, in handy ejector box, supplied 10 sets in counter display.

Art.-No.	Contents			Barcode
115700	1 bitholder screwdriver, 1 flexible extension, sockets 3, 3.5, 4, 4.5, 5, 5.5, 6, 7 mm, 1 Adaptor 4mm, Torx T4,5,6,7,8,9,10,15,20 Hexagon 0.7, 0.9, 1.3, 1.5, 2.0, 2.5, 3.0, 4.0mm, Slotted 1.5, 2.0, 2.5, 3.0, 3.5, 4.0 mm, PH000, PH00, PH0, PH1, PZ0, PZ1		10	



Power-Box STANDARD, 67-piece



Power-Box STANDARD, 1/4" hexagon drive bits to ISO 1173, C 6.3 and E 6.3, Quick release bit holder with permanent magnet, 1/4" hexagon shank to ISO 1173, E 6.3, with colour coded rings, Masonry, metal and wood drills with 1/4" hexagon shaft E 6.3, CrV sockets with engineer's corners, 2 long bit holders, in sturdy metal case.

Part.-No.	Contents			EAN
106300	see diagram below		4	4 0 093 11 063007

35 Bits, 25 MM long, shaft 1/4" C6.3

- 2, 4, 6 MM
- PH Nr. 0, 1, 1, 2, 2, 3
- PZ Nr. 1, 1, 2, 2, 3
- T15, T20, T25
- T8, T9, T10, T15, T20, T25, T30, T40
- 2, 2.5, 3, 4, 5, 6 MM
- 3, 4, 5, 6 MM

9 long bits, 70 MM long, shaft 1/4" E6.3

- 3 MM
- PH Nr. 2
- PZ Nr. 2
- T20, T25
- 4, 6, 8, 10 MM

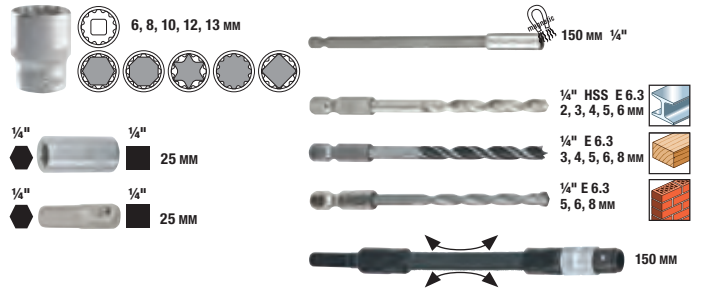

Power-Box STANDARD, 92-piece



Power-Box STANDARD, 1/4" hexagon drive bits to ISO 1173, C 6.3 and E 6.3, including bits with special purpose profiles, for use with electrical appliances and components etc., bit holder with permanent magnet, 1/4" hexagon shank to ISO 1173, E 6.3, CrV sockets Super Lock, long bit holder, ratchet screwdriver handle with 1/4" hexagon drive to ISO 1173, in sturdy metal case.

Part.-No.	Contents			EAN
106800	see diagram below		6	4 0 093 11 106800

63 x - 25 MM -

- 2, 4, 6.5 MM
- Nr. 0, 1, 1, 2, 2, 3
- Nr. 1, 1, 2, 2, 3
- T10, T15, T20, T25, T30, T40
- 8, 9, 10, 15, 20, 25, 27, 30, 40

- 0, 1, 2, 3
- 4, 6, 8, 10
- 5, 6, 8
- 2, 2.5, 3, 4, 5, 6, 8
- 5/64", 3/32", 7/64", 1/8", 9/64", 5/32"

- 1, 2, 3, 4
- 6, 8, 10
- 1, 2, 3
- 1 x

17 x - 70 MM -

- 3 MM
- Nr. 2
- Nr. 2
- 10, 15, 20, 25, 30, 40
- 1, 2, 3, 4
- 4, 6, 8, 10

6 X 4, 4.5, 5, 5.5, 6, 8 MM

- 1 X 60 MM
- 1 X 150 MM
- 1 X 25 MM
- 1 X 50 MM
- 1 X AUTO

Bit-Sets

Bit-Set STANDARD, 31-piece



Bit-Box STANDARD, 1/4" hexagon drive bits to ISO 1173, C 6.3, quick release bit holder with permanent magnet 1/4" hexagon shank to ISO 1173, E 6.3, with colour coded rings to distinguish the screw head types, for all common screwdriving jobs in handy, space-saving folding case, easy and convenient bit selection through separately removable storage modules.

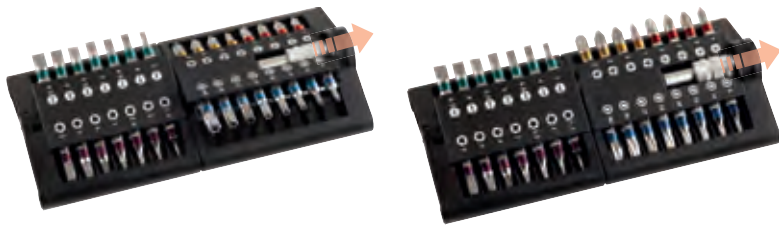

Part.-No.	Contents			EAN
107100			8	



Precision Micro Bit Set STANDARD, 11-piece



Precision Micro Bit Set STANDARD, 11-piece, 1/4" hexagon drive bits to ISO 1173, C 6.3, holder with permanent magnet 1/4" hexagon shank to ISO 1173, C 6.3, Quick-change handle with 1/4" hexagon fitting to ISO 1173, for use with glasses, mobile phones, cameras, MP3 players, laptops, remote controls, in practical, self-opening storage cassette.

Part.-No.	Contents			EAN
117700	see diagram below		10	



Bit-Box STANDARD, 32-piece



Bit Box STANDARD, 32-piece, 1/4" hexagon drive bits to ISO 1173, C 61.3, industrial quality, with colour coded rings to distinguish the screw head types, quick release bit holder with 1/4" hexagon fitting to ISO 1173, C 6.3, box with handy belt clip; supplied 12 sets in counter display.

Part.-No.	Contents			EAN
118800	see diagram below		12	 4 0 0 9 3 1 1 1 8 8 0 0 7

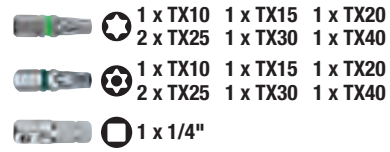
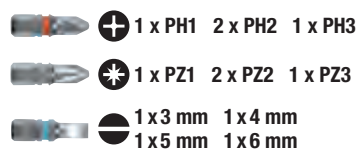

Bit Box STANDARD, 17-piece, Bits and sockets



Bit Box STANDARD, 17-piece, Bits and sockets, Bits: 1/4" hexagon drive to ISO 1173, C 6.3, industrial quality, with colour coded rings to distinguish the screw head types, CrV sockets with engineer's corners, for all common screw head types, stainless steel ratchet handle with 1/4" hexagon drive to ISO 1173, box with handy belt clip. Supplied 12 sets in counter display.

Part.-No.	Contents			EAN
118900	see diagram below		12	 4 0 0 9 3 1 1 1 8 9 0 0 4

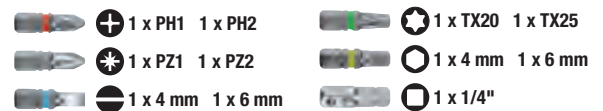

Bit Box STANDARD, 35-piece, Bits



Bit Box STANDARD, 35-piece, Bits: 1/4" hexagon drive to ISO 1173, C 6.3; Micro bits: 4mm hexagon drive, industrial quality, with colour coded rings to distinguish the screw head types, bit holder 1/4" hexagon drive to ISO 1173, E 6.3; Micro magnetic holder with 4mm hexagon drive, 2-part handle, box with handy belt clip. Supplied 12 sets in counter display.

Part.-No.	Contents			EAN
119000	see diagram below		12	 4 0 0 9 3 1 1 1 9 0 0 0 0

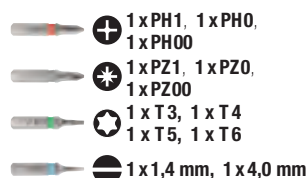
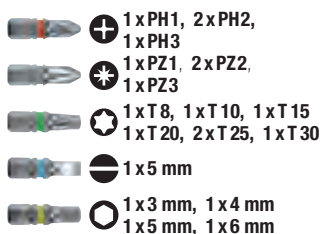

Bit-Sets



POWER BOX, 25-piece







In sturdy plastic case with positive slide closure. The perfect add-on for any cordless screwdriver or drill, or mains drill. Wood, metal and masonry drills, long and short screwdriver bits all in the most common sizes; quick and easy bit change with the bit holder and quick-release bit holder included. All bits and holders are made from high quality chrome vanadium steel.



Part.-No.	Contents			EAN
109025	see diagram below		20	

1/4" 9 X 25 MM C 6.3
 ⊕ 1, 2, 3
 ⊖ 4, 5, 6
 ⊕ 1, 2, 3

1/4" 3 X 50 MM E 6.3
 ⊕ 2
 ⊖ 6
 ⊕ 2

HSS
5x
 2, 3, 4, 5, 6 MM

HM (HW) TCT
3x
 4, 5, 6 MM

CV
3x
 4, 5, 6 MM



 1x  1x





POWER BOX, 44-piece







In sturdy plastic case with positive slide closure. The perfect add-on for any cordless screwdriver or drill, or mains drill. Wood, metal and masonry drills, long and short screwdriver bits all in the most common sizes; quick and easy bit change with the bit holder and quick-release bit holder included. All bits and holders are made from high quality chrome vanadium steel.



Part.-No.	Contents			EAN
109044	see diagram below		20	

1/4" 16 X 25 MM C 6.3
 ⊕ 1, 2, 3
 ⊖ 4, 5, 6
 ⊕ T10, T15, T20, T25, T27, T30, T40
 ⊕ 1, 2, 3

1/4" 6 X 50 MM E 6.3
 ⊕ 1, 2
 ⊖ 4, 6
 ⊕ 1, 2

HSS
11x
 1, 1.5, 2, 2.5, 3, 3.5, 4, 4.5, 5, 5.5, 6 MM

HM (HW) TCT
4x
 4, 5, 6, 8 MM

CV
5x
 3, 4, 5, 6, 8 MM

 1x

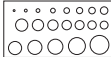
 1x



POWER BOX, 75-piece



In sturdy plastic case with secure aluminium closure clips and overmoulded carrying handle. The perfect add-on for any cordless screwdriver or drill, or mains drill. Comprehensive assortment of wood, metal and masonry drill bits, hexagon sockets, long and short screwdriver bits in all the common sizes for easy use in the machine. Rapid drill or screwdriver bit changing with the bit holder included. Also included 2 flat wood bits for through holes at low rpm in softwood. All bits and holders are made from high quality chrome vanadium steel.

Part.-No.	Contents			EAN
109575	see diagram below		10	

- 1/4"**
32 X 25 MM C 6.3
 ⊕ 0, 1, 2, 2, 2, 3
 ⊖ 3, 4, 5, 5, 6, 6, 7
 ⊛ T10, T15, T20, T25, T27, T30, T40
 ⊕ 0, 1, 2, 2, 2, 3
 ⊖ 2, 2.5, 3, 4, 5, 6

- 1/4"** **12 X 50 MM E 6.3**
 ⊕ 1, 2, 2, 3
 ⊖ 4, 5, 6, 6
 ⊕ 1, 2, 2, 3
 1/4"  **1x**
 1/4"  **6x** 4, 5, 6, 7, 8, 10 MM

HSS

- 11x**
 1, 1.5, 2, 2.5, 3, 3.5, 4, 4.5, 5, 5.5, 6 MM



HM (HW) TCT

- 4x**
 4, 5, 6, 8 MM

CV

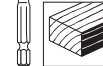
- 5x**
 3, 4, 5, 6, 8 MM

- 2x E 6.3**
 16, 22

- 1x E 6.3**

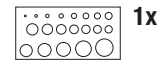

Bit-Box STANDARD, 100-piece



In sturdy plastic case with secure aluminium closure clips and overmoulded carrying handle. The perfect add-on for any cordless screwdriver or drill, or mains drill. Comprehensive assortment of wood, metal and masonry drill bits, hexagon sockets, holesaws, long and short screwdriver bits in all the common sizes for easy use in the machine. Rapid drill or screwdriver bit changing with the bit holder included. Also included 3 flat wood bits for through holes at low rpm in softwood, and 4 holesaws for large holes in wood and plasterboard etc.. All bits and holders are made from high quality chrome vanadium steel.

Part.-No.	Contents			EAN
109001	see diagram below		10	

- 1/4"**
40 X 25 MM C 6.3
 ⊕ 0, 0, 1, 1, 2, 2, 2, 3, 3
 ⊖ 3, 4, 4, 5, 5, 6, 6, 7
 ⊛ T10, T15, T20, T25, T27, T30, T40
 ⊕ 0, 0, 1, 1, 2, 2, 2, 3, 3,
 ⊖ 2, 2.5, 3, 3.5, 4, 5, 6

- 1/4"** **12 X 50 MM E 6.3**
 ⊕ 1, 2, 2, 3
 ⊖ 4, 5, 6, 6
 ⊕ 1, 2, 2, 3

HSS

- 14x**
 1, 1.5, 2, 2.5, 3, 3.5, 4, 4.5, 5, 5.5, 6, 7, 8, 10 MM

HM (HW) TCT





- 5x**
 4, 5, 6, 8, 10 MM



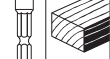

CV

- 5x**
 3, 4, 5, 6, 8 MM

- 3x E 6.3**
 16, 22, 25

- 1x E 6.3**

-  **8x** 4, 5, 6, 7, 8, 9, 10, 13 MM
 1/4"  **1x**
 **3x** 6, 8, 10
 **1x**

-  **1x**
 **1x**
 **4x** 32, 38, 44, 54 MM

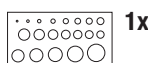



DRILL ACCESSORIES

Chucks

Rasps, Burrs

Countersinks, conecut drills

Mounted grinding points

Drill stands

Pumps

Mixing paddles

Drill accessories



The benefits of drill accessories

- Rotary files, rasps, countersinks, step- and conecut drills for wood and metalworking
- Attachments, drill stands, flexible shafts, pumps, mixing paddles for use in popular mains and cordless drills

Programme overview drill accessories



Chucks

★★★★★

Key type and keyless chucks in the most common capacities and fittings for popular drills.

Page 102 - 104



Rasps and burrs

★★★★★

Rasps and burrs for wood and metalworking, available in a wide variety of shapes.

Page 105 - 109



Countersinks

★★★★★

Countersinks for wood and metalworking, available in a wide variety of patterns.

Page 110 - 111



Step drills and conecut drills

★★★★★

Step drills and conecut drills for metalworking, available in a variety of patterns.

Page 112 - 113

kwb-Info

A safer job



Our eyes, as one of the most important sensory organs, must always be protected while working. That's why kwb has put together for all common situations when drilling, shaping, grinding or welding indoors or outdoors, a high quality protective eyewear range also suitable for spectacle-wearers

You can find all the relevant information in our **Personal Protection catalogue**, or on the Internet at www.kwb.eu.



Attachments ★★★★★
Attachments for mains and cordless drills.

Page 114



Mounted grinding points ★★★★★
Mounted grinding points for metalworking, available in a wide variety of shapes.

Page 115 - 117



Pumps ★★★★★
Drill-powered pumps for standard drills. For filling with and pumping out of liquids.

Page 118 - 119



Paint and plaster mixing paddles ★★★★★
For mixing emulsion and wall paints, mortar, plaster, screed and concrete, for use in standard mains drills.

Page 120 - 121



Key type drill chuck

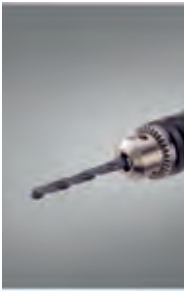

Key type drill chuck to DIN 6349 L, impact resistant, with S2 chuck key, inside thread (Form B), through bored for insertion of securing screw for reverse operation, for standard and reversible drills.

Art.-No.	Drive	Key no.	Key type	Capacity			Barcode
291379	1/2" x 20	2858	S2	1.5 - 13 mm		2	4 009312 913790



Keyless drill chuck



Keyless drill chuck, heavy duty pattern, with overtightening protection, tungsten carbide tipped jaws, impact resistant, inside thread (Form B), through bored for insertion of securing screws for reverse operation, for standard and reversible drills, allowing quick bit changeover.

Art.-No.	Drive	Capacity			Barcode
297872	1/2" x 20	1.5 - 13 mm		2	4 009312 978720



Keyless drill chuck



Keyless drill chuck, light duty pattern, with overtightening protection, tungsten carbide tipped jaws, impact resistant, inside thread (Form B), through bored for insertion of securing screws for reverse operation, for cordless drills and drivers, also DIY standard and reversible mains drills, allowing quick bit changeover.

Art.-No.	Drive	Capacity			Barcode
297472	1/2" x 20	1.5 - 13 mm		2	4 009312 974722





Drill accessories

Keyless drill chuck



Keyless chuck, light duty, inside thread (Form B), through bored for insertion of retaining screw for reverse running, for cordless drills and drivers, as well as DIY standard and reversible mains drills, allowing quick bit changing.





Art.-No.	Drive	Capacity			Barcode
298472	1/2" x 20	1.5 - 13 mm		2	



Key type drill chuck



Key type drill chuck to DIN 6349 L, with key S14 KG, 1/4" hexagon shank to ISO 1173, E 6.3, for cordless and mains screwdrivers with 1/4" hexagon fitting.





Art.-No.	Drive	Capacity			Barcode
292600	○ 1/4" E 6.3	0.5 - 6.5 mm		1	



Keyless drill chuck



Keyless chuck, to DIN 6349 L, 1/4" hexagon shank to ISO 1173, E 6.3, for cordless and mains drivers with 1/4" hexagon drive.





Art.-No.	Drive	Capacity			Barcode
292500	○ 1/4" E 6.3	0,5 - 6,5 mm		2	



SDS-Plus drill chuck adaptor



SDS Plus drill chuck adaptor, with M6 left hand thread securing screw for reversing, for use with suitable drill chucks, on reversible hammer drills with hammer stop.







Art.-No.	Drive	for			Barcode
299900	1/2" x 20	291379, 297472, 297872, 298472		5	



Chuck key









Chuck key, DIN gearing for all commonly used key type drill chucks from AEG, BOSCH, METABO etc.

Art.-No.	for	Key type			Barcode
carded					
285820	2913	S2		10	
285920	2913	S2, long		10	

Chuck key, JACOBS gearing



Chuck key, JACOBS gear, for Black & Decker, Makita chucks.

Art.-No.	for	Key type			Barcode
283620	2810, 2926	S14 KG		10	
273820	2813	S8, K30		10	

360° angle drilling attachment



Compact 360 degree angle drilling attachment with 10mm keyless chuck. By unscrewing the ball joint the chuck can quickly be aligned in any desired position in a 360 degree circle. This makes the tools suitable for left- and right-handers. Simply turn the handle to lock the ball joint. The textured rubber handle gives a solid grip for drilling even in the most awkward situations. For safety reasons the maximum drill length/ diameter to be used is 190mm/ 3/4". Thanks to the planetary gear inside you can take on the toughest jobs including building and assembly work. With its hexagon drive shaft the attachment fits easily into standard cordless and mains drills. The unit is not suitable for use with holesaws, or longer drill bits such as wall drills, framework drills and augers.



Art.-No.	Contents			Barcode
298600	360° angle drilling attachment		1	

Drill accessories

Hollow wood rasps



Rotary wood rasps, carbon steel, toothed on the head, for filing, drilling, hole elongation, grooving, profiling and plug-cutting, for wood.

Art.-No.	Ø outside	Ø inside	mm			Barcode
705015	15 mm	10 mm	6		6	
705020	20 mm	15 mm	6		6	
705025	25 mm	20 mm	6		6	



Rotary rasps for wood



Rotary rasps, carbon steel, for filing, profiling and surface preparation in recesses, for woodworking

Art.-No.	Shape	Head Ø x height	mm			Barcode
494300	Pear-shaped	16 x 30 mm	6		6	



Rotary rasps for wood



Rotary rasps, carbon steel, for filing, profiling and surface preparation in recesses, for woodworking

Art.-No.	Shape	Head Ø x height	mm			Barcode
494500	Cylindrical	16 x 30 mm	6		6	



Rotary rasps for wood



Rotary rasps, carbon steel, for filing, profiling and surface preparation in recesses, for woodworking

Art.-No.	Shape	Head Ø x height	mm			Barcode
494600	Cylindrical rounded end	13 x 35 mm	6		6	



Rotary rasps for wood



Rotary rasps, carbon steel, for filing, profiling and surface preparation in recesses, for woodworking.

Art.-No.	Shape	Head Ø x height	mm			Barcode
494700	Cone shaped	15 x 35 mm	6		6	4 009314 947007

Rotary rasps for wood



Rotary rasps, carbon steel, for filing, profiling and surface preparation in recesses, for woodworking.

Art.-No.	Shape	Head Ø x height	mm			Barcode
494800	Spherical	16 mm	6		6	4 009314 948004

Rotary rasps for non-ferrous metal



Rotary rasps, carbon steel, for filing, profiling and surface preparation in recesses, for wood and non-ferrous metal.

Art.-No.	Shape	Head Ø x height	mm			Barcode
494900	Cylindrical	16 x 30 mm	6		6	4 009314 949008

Rotary rasps for non-ferrous metal



Rotary rasps, carbon steel, for filing, profiling and surface preparation in recesses, for wood and non-ferrous metal.

Art.-No.	Shape	Head Ø x height	mm			Barcode
495000	Cone shaped	15 x 35 mm	6		6	4 009314 950007

Drill accessories

Rotary rasp Set 6-piece



Rotary rasps, carbon steel, for filing, profiling and surface preparation in recesses, for wood and non-ferrous metal.

Art.-No.	Shape	Contents	mm			Barcode
495500	Cylindrical, cylindrical rounded end, conical, spherical/cylindrical, conical	4 x wood, 2 x non-ferrous metal	6		6	4 009314 955002



HSS Rotary burrs



Rotary burrs, HSS, for milling, profiling and finishing of metal.

Art.-No.	Shape	Head Ø x height	mm			Barcode
700140	Cylindrical rounded end	13 x 32 mm	6		6	4 009317 001409



HSS Rotary burrs



Rotary burrs, HSS, for milling, profiling and finishing of metal.

Art.-No.	Shape	Head Ø x height	mm			Barcode
700340	Conical, rounded point	12 x 31 mm	6		6	4 009319 003403



HSS Rotary burrs



Rotary burrs, HSS, for milling, profiling and finishing of metal.

Art.-No.	Shape	Head Ø x height	mm			Barcode
700540	Spherical	12 x 12 mm	6		6	4 009317 005407



HSS Rotary burrs



Rotary burrs, HSS, for milling, profiling and finishing of metal.

Art.-No.	Shape	Head Ø x height	mm			Barcode
700740	Cylindrical	13 x 30 mm	6		6	4 009317 007401

HSS Rotary burrs



Rotary burrs, HSS, for milling, profiling and finishing of metal.

Art.-No.	Shape	Head Ø x height	mm			Barcode
700840	Conical, pointed	13 x 30 mm	6		6	4 009317 008408

Milling cutters



Milling cutters, carbon steel, for milling, profiling, for woodworking.

Art.-No.	Shape	Head Ø x height	mm			Barcode
557100	Rebate	25 x 20 mm	8		6	4 009315 571003

Milling cutters



Milling cutters, carbon steel, for milling, profiling, for woodworking.

Art.-No.	Shape	Head Ø x height	mm			Barcode
557800	Slotting	2,5 x 35 mm	8		6	4 009315 578002

Milling cutters



Milling cutters, carbon steel, for milling, profiling, for woodworking.

Art.-No.	Shape	Head Ø x height	mm			Barcode
557900	Slotting	5,0 x 35 mm	8		6	4 009315 579009

Drill accessories

Slotting saw



Slotting saw, for deep narrow slots, use freehand or static with the kwb drill stand, for wood.

Art.-No.	∅ mm	mm	mm			Barcode
557000	50	8	0,8 mm		6	4 009315 570006



Miniature drill accessory Kit, 105 pcs.



Mini-drill accessory set, for use in all mini-drill systems and flexible shafts, 3 mm shank, for sanding, milling, brushing and polishing, for wood and metal.

Art.-No.	Contents			Barcode
510900	Arbors, polishing discs, grinding discs, cutting discs, brushes, polishing compound, grinding points, abrasive rolls, sharpening stone, rotary burrs		10	4 009315 109008

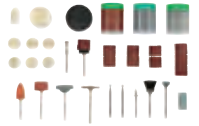
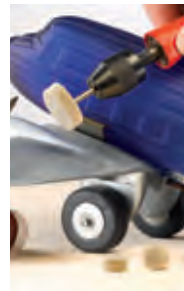

kwb-Info

A safer job

It's always a good idea to wear protective gloves when your hands could possibly be injured, for example in building work with sharp-edged objects etc.

For all types of work, a safe grip and wearer comfort are the prime requirements for the correct type of glove.







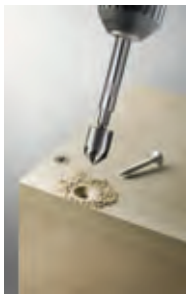

You can find all the relevant information in our **Personal Protection catalogue**, or on the Internet at **www.kwb.eu**.



Countersink carbon steel





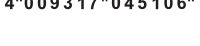

Countersink, carbon steel, 90 degree, 5-flute, to countersink for flush fitting of countersunk screws, for wood and non-ferrous metal.

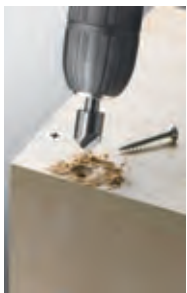
Art.-No.	Ø mm	ℓ mm			Barcode
704210	8	8		6	
704310	12	8		6	
704410	16	8		6	
704510	20	8		6	

Countersink Set, carbon steel, 3-piece









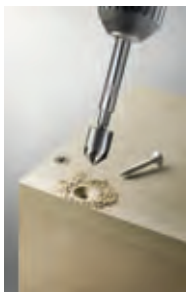

Countersink set carbon steel, 90 degree, single flute, to countersink for flush fitting of countersunk screws, for wood and non-ferrous metal.

Art.-No.	Ø mm	ℓ mm			Barcode
511100	8, 12, 16	6, 8		6	

Countersink carbon steel, 1/4" hexagon shank C6.3



Countersink, carbon steel, 90 degree, 7-flute, 1/4" hexagon shank, for cordless drivers and bit holders, to countersink for flush fitting of countersunk screws, for wood and non-ferrous metal.







Art.-No.	Ø mm	ℓ mm			Barcode
704610	10	1/4"		6	
704710	13	1/4"		6	
704810	16	1/4"		6	



Countersink HSS

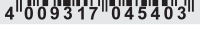

HSS countersinks 90°, 5-flute, for countersinking for flush fitting of countersunk screws in metal.

Art.-No.	Ø mm	ℓ mm			Barcode
704340	12	8		6	
704440	16	8		6	
704540	20	8		6	

Drill accessories

Countersink HSS, 1/4" hexagon shank C6.3



Countersink, HSS, 90 degree, 3-flute, 1/4" hexagon shank, for cordless drivers and bit holders, to countersink for flush fitting of countersunk screws, for metalworking.

Art.-No.	Head diameter	mm			Barcode
704640	10 mm	● 1/4		6	4 009317 046400
704740	12 mm	● 1/4		6	4 009317 047407
704840	16 mm	● 1/4		6	4 009317 048404



Slip-on countersink set carbon steel, 3-piece



Slip on countersink set, carbon steel, 90 degree, 5-flute, to fit on to HSS and wood drill bits, to drill and countersink in one operation, to countersink for flush fitting of countersunk screws in wood.

Art.-No.	for	Head Ø x height			Barcode
513050	Drills 4, 5, 6 mm	12 x 19 mm		5	4 009315 130507



kwb-Info

A safer job

Many jobs will generate dust and particles, or vapours and gases, or will involve working with potentially harmful substances. Protect your lungs and airways against these hazards! This is why kwb has put together a comprehensive range of protective masks, with and without breather valves.

For all common applications in the specified breathing protection categories.



Step drills HSS











Step drill, HSS, with starter point, for drilling from small to large diameters with pre-drilling in thin sheet material, burr-free thanks to chip breaker, no work-hardening, graduated in the most popular drill sizes, for steel sheet, non-ferrous metals and plastics.

Art.-No.	Head diameter	By steps			Barcode
525820	4 - 20 mm	2 mm		1	 4 009315 258201
525830	6 - 30 mm	2 mm		1	 4 009315 258300

Conecut drills HSS





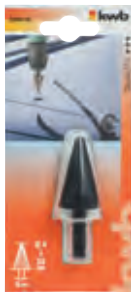
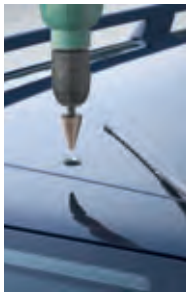

Conecut drill, HSS, with starter point, for making holes increasing continuously from small to large diameter without pre-drilling in thin sheet metal, burr-free thanks to chip-breaking action, no work hardening, for sheet steel, non-ferrous metals and plastics.

Art.-No.	Head diameter	 mm			Barcode
525000	3 - 14 mm	10		1	 4 009315 250007
525100	6 - 20 mm	10		1	 4 009315 251004
525200	16 - 30 mm	10		1	 4 009315 252001

Car body reamer, carbon steel



Car body reamer, carbon steel, for enlarging holes from small to large diameters in thin non-ferrous metals, plastics and wood, also suitable for car radio aerial installation.

Art.-No.	Head diameter	 mm			Barcode
524010	4 - 24 mm	8		6	 4 009315 240107

TITANIUM HSS rotary file

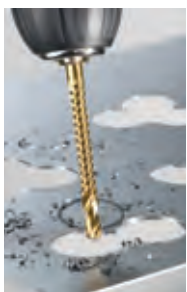

Rotary file HSS, titanium nitrided, for drilling and milling, for enlarging holes and making slots, for sheet steel, non-ferrous metals and plastics, especially suitable for long-term professional use.

Art.-No.	Ø mm			Barcode
494100	6		1	 4 009314 941005

Drill accessories

Rotary file, HSS



Rotary file HSS, for drilling and milling, for enlarging holes and making slots, for sheet steel, non-ferrous metals and plastics, especially suitable for long-term professional use.

Art.-No.	Ø mm			Barcode
493900	6		6	



Rotary file, carbon steel



Rotary file, carbon steel, for drilling and filing, for making slots and elongating holes, for wood and plastics.

Art.-No.	Ø mm			Barcode
494000	6		6	



kwb-Info

A safer job



Our eyes, as one of the most important sensory organs, must always be protected while working. That's why kwb has put together for all common situations when drilling, shaping, grinding or welding indoors or outdoors, a high quality protective eyewear range also suitable for spectacle-wearers



You can find all the relevant information in our **Personal Protection catalogue**, or on the Internet at **www.kwb.eu**.



Drilling/milling guide



Drilling and milling attachment, for drills with 43 mm Euro-collar, two columns can swivel 90-45 degrees, for controlled drilling to exact depths or angles, continuous depth adjustment, exact control for serial drilling in lines, integral V-groove for securely holding curved workpieces.

Art.-No.	for			Barcode
778400	Electric drills with 43 mm Euro collar		1	4 009317 784005

Drill bench mounting clamp



Drill bench mounting bracket, for drills with 43 mm Euro-collar, rotates through 360 degrees, swivels vertically to 90 degrees, can be used horizontally or vertically, for quickly converting drills, trimmers and die grinders to stationary use on workbenches for sanding, sharpening, cleaning and polishing.

Art.-No.	for			Barcode
779600	Electric drills with 43 mm Euro collar		1	4 009317 796008

PROFI drill press stand



Suitable for use with all standard drills with 43 mm Euro-collar, for precise drilling and milling in wood/ metal profiles, with return spring, depth stop and mm scale. Die cast base plate 175 x 210 mm with fastening slots for machine vice (Part no. 777068, 80 mm, not included in set). Total height 500 mm, hexagonal column rotates through 360 deg., column diameter 34mm, depth of feed 130 mm.

Art.-No.	Contents			Barcode
777800	Professional drill stand			4 009317 778004

Flexible Shaft



Flexible shaft, 950 mm long, with keyless quick action drill chuck, light pattern, with maintenance-free special bearings, max. 3000 rpm, for precision work and freehand milling of wood, plastics, ferrous and non-ferrous metals, ideal for modelmaking and engraving.

Art.-No.	Length	mm	Capacity	Shaft \varnothing mm			Barcode
522300	950	6	0.5 - 6	3,2		1	4 009315 223001

Roller Trestle



Roller trestle, collapsible, continuously adjustable working height 650-1100 mm, for use with all standard machines and workbenches, to support and feed long planks, boards, rods and tubes, the ball-bearing mounted rollers allow the workpiece to be easily fed to the machine.





Art.-No.	Length			Barcode
785900	300		1	4 009317 859000

Drill accessories

Mounted grinding points



Mounted grinding points, Aluminium oxide, for removing ridges, welding spatter, fine surface grinding, for metal, glass, ceramics and plastics, for use in drills and die grinders, max. Rpm 30,000.





Art.-No.	Shape	Head Ø x height			Barcode
551000	Cylindrical	25 x 25 mm		6	



Mounted grinding points



Mounted grinding points, Aluminium oxide, for removing ridges, welding spatter, fine surface grinding, for metal, glass, ceramics and plastics, for use in drills and die grinders, max. Rpm 30,000.



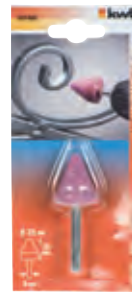
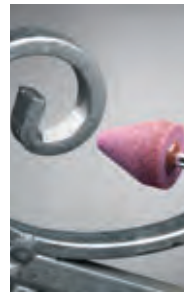

Art.-No.	Shape	Head Ø x height			Barcode
551400	Conical, rounded point	25 x 32 mm		6	



Mounted grinding points



Mounted grinding points, Aluminium oxide, for removing ridges, welding spatter, fine surface grinding, for metal, glass, ceramics and plastics, for use in drills and die grinders, max. Rpm 30,000.



Art.-No.	Shape	Head Ø x height			Barcode
551700	Conical, pointed	25 x 32 mm		6	



Mounted grinding points



Mounted grinding points, Aluminium oxide, for removing ridges, welding spatter, fine surface grinding, for metal, glass, ceramics and plastics, for use in drills and die grinders, max. Rpm 30,000.



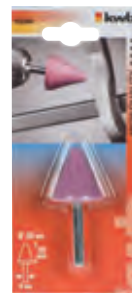

Art.-No.	Shape	Head Ø x height			Barcode
552300	Conical, pointed	30 x 30 mm		6	



Mounted grinding points



Mounted grinding points, Aluminium oxide, for removing ridges, welding spatter, fine surface grinding, for metal, glass, ceramics and plastics, for use in drills and die grinders, max. Rpm 30,000.

Art.-No.	Shape	Head Ø x height			Barcode
553000	Cylindrical	16 x 32 mm		6	



Mounted grinding points



Mounted grinding points, Aluminium oxide, for removing ridges, welding spatter, fine surface grinding, for metal, glass, ceramics and plastics, for use in drills and die grinders, max. Rpm 30,000.

Art.-No.	Shape	Head Ø x height			Barcode
553300	Cylindrical pointed	16 x 32 mm		6	4 009315 533001

Mounted grinding points



Mounted grinding points, Aluminium oxide, for removing ridges, welding spatter, fine surface grinding, for metal, glass, ceramics and plastics, for use in drills and die grinders, max. Rpm 30,000.

Art.-No.	Shape	Head Ø x height			Barcode
555000	Disc	40 x 10 mm		6	4 009315 555008

Mounted grinding points

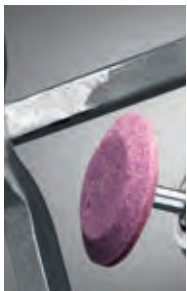

Mounted grinding points, Aluminium oxide, for removing ridges, welding spatter, fine surface grinding, for metal, glass, ceramics and plastics, for use in drills and die grinders, max. Rpm 30,000.

Art.-No.	Shape	Head Ø x height			Barcode
555200	Disc, dished	40 x 10 mm		6	4 009315 552002

Mounted grinding point set, 5-piece



Mounted grinding point set, 5-piece, aluminium oxide, for removing ridges, welding spatter, fine surface grinding, for metal, glass, ceramics and plastics, for use in drills.





Art.-No.	Shape	Head Ø x height			Barcode
510000	Cylindrical rounded end, spherical, conical rounded end, cylindrical, conical pointed	15 x 25 mm / 25 x 25 mm / 25 x 43 mm / 25 x 16 mm / 21 x 25 mm		6	4 009315 100005

Drill accessories

Mini mounted grinding point set, 5-piece

★★★★★

Mini mounted grinding point set, 5-piece. Aluminium oxide, for removing ridges, welding spatter, fine surface grinding, for metal, glass, ceramics and plastics, for use in mini drill systems and flexible shafts



Art.-No.	Shape	Head Ø x height			Barcode
510100	Cylindrical rounded end, conical pointed, tapered cylinder, cylindrical, conical rounded end	16 x 15 mm / 20 x 13 mm / 16 x 15 mm / 13 x 13 mm / 20 x 13 mm		6	



Knife and scissor sharpener

★★★★

Knife and scissor sharpener, aluminium oxide grinding wheels, for sharpening all household knives and scissors with straight blades, for use in electric drills.



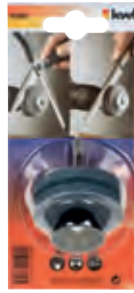

Art.-No.	 mm			Barcode
493800	6		6	



Sharpening stone

★★★★★

Sharpening stone, ceramic grindstone, coarse and fine, aluminium oxide, for grinding and sharpening of tools, for example wood chisels and lathe tools.

Art.-No.	Dimensions			Barcode
455000	150 x 50 x 25 mm		1	

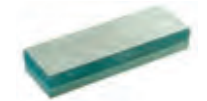

COMPACTA-Pump P 57



COMPACTA Pump P57, self-priming, with pressure regulation, built-in drill holder, for drills with 43 mm Euro-collar, with debris filter, outlet thread 3/4", for all commonly used hose adaptors 1/2" and 3/4", for pumping liquids, for example emptying water butts and paddling pools. Hose adaptor and hose not included.

Art.-No.	Contents			Barcode
505700	Shank size 8 mm, output 3000 l/h, head 40m, lifting (priming) height +/- 4 m, output pressure 4 bar, dry running maximum 30 seconds		2	4 009315 057000

Combi-Pump P 60



Combi-Pump P60, self-priming, for drills, hose adaptor thread 3/4", for all standard hose adaptors 1/2" and 3/4", for filling and emptying liquids, for example emptying water butts or paddling pools.

Art.-No.	Contents			Barcode
506000	Shank size 8 mm, output 3000 l/h, head 40 m, lifting (priming) height +/- 4 m, output pressure 4 bar, dry running maximum 30 seconds		2	4 009315 060002

kwb-Info

COMPACTA Pump P57

The self-priming COMPACTA Pump P57, with pressure regulation and built-in drill holder is for filling and emptying of liquids.

For emptying:

- Garden ponds
- Boats
- Aquariums
- Flooded cellars
- Water butts
- Paddling pools etc.

For watering:

- Gardens
- Flowerbeds

Also for spraying of garden chemicals.







Drill accessories

MAXI-Pump P 63



Maxi-Pump P63, self-priming, for drills, hose outlet 1/2", to be fitted using hose clips, for filling and emptying liquids, eg emptying water butts and paddling pools.

Art.-No.	Contents			Barcode
506300	Shank size 8mm, output 2400 l/h, head 40 m, lifting (priming) height +/- 4 m, output pressure 4 bar, dry running maximum 30 seconds		4	



Maxi-Pump P63, Display



Maxi-Pump P63, self-priming, for drills, hose outlet 1/2", to be fitted using hose clips, for filling and emptying liquids, eg emptying water butts and paddling pools.





Art.-No.	Contents			Barcode
506399	16		Z16	



Mini-Pump P 61



Mini-Pump P61, self-priming, for drills, hose outlet 1/2", to be fitted using hose clips, for filling and emptying liquids, eg emptying water butts and paddling pools.

Art.-No.	Contents			Barcode
506100	Shank size 8 mm, output 1500 l/h, head 20 m, lifting (priming) height +/- 3 m, output pressure 5 bar, dry running maximum 10 seconds		4	



Mini-Pump P61, Display



Mini-Pump P61, self-priming, for drills, hose outlet 1/2", to be fitted using hose clips, for filling and emptying liquids, eg emptying water butts and paddling pools.

Art.-No.	Contents			Barcode
506199	25		Z25	



Paint mixers



Paint mixer, nylon wings, for mixing varnish, glaze and paint, strong construction, free-running, for use in standard electric drills, stirs the mixture downwards to avoid splashing, ideal for mixing small volumes.

Art.-No.	Ø mm	Capacity	Length	↕	☑	📦	Barcode
497006	60	max. 5 l	350 mm	6	☑	1	
497008	80	10 - 15 l	400 mm	8	☑	1	

Heavy duty paint mixers



Mixers for paint, metal spiral, for mixing emulsion and wall paint, thin mortar, heavy duty pattern, smooth running, plastic sheathed, for use in commonly used drills, minimum 500 watt.

Art.-No.	Ø mm	Capacity	Length	↕	☑	📦	Barcode
497206	60	max. 5 l	400 mm	8	☑	1	
497208	80	5 - 15 l	400 mm	8	☑	1	
497210	100	10 - 25 l	590 mm	10	☑	1	
497212	120	20 - 30 l	590 mm	10	☑	1	

Mortar mixer



Mixers for mortar, metal spiral, for mixing mortar, tile adhesive, all types of plaster, heavy duty pattern, smooth running, plastic sheathed, no splashing of paint in use, for use in commonly used drills, minimum 400 watt, good mixing with low demand on the machine.

Art.-No.	Ø mm	Capacity	Length	↕	☑	📦	Barcode
497607	70	4 - 7 l	400 mm	8	☑	1	
497609	90	7 - 10 l	400 mm	8	☑	1	
497612	100	10 - 15 l	590 mm	10	☑	1	

Mortar mixer M14



Mixers for mortar, metal spiral, M14 outside thread with hexagon flange, for mixing mortar, cement, screed, concrete and adhesives, heavy duty pattern, easy, safe and smooth running, powder coated, no splashing of paint in use, for use in commonly used drills, minimum 700 watt.

Art.-No.	Ø mm	Length	☑	📦	Barcode
497632	120	590 mm	☑	1	



Drill accessories

Heavy duty plaster mixer



Mixers for adhesive, metal spiral, for mixing flooring adhesive, filler, tile adhesive, plaster and screed, heavy duty pattern, smooth running, plastic sheathed, no splashing of paint in use, for use in commonly used drills, minimum 500 watt, gives homogenous mixing, round vanes save energy.



Art.-No.	Ø mm	Capacity	Length	~	☑	☐	Barcode
497708	85	5 - 10 l	400 mm	8	☑	☐	
497711	105	10 - 15 l	590 mm	10	☑	☐	

kwb-Info



kwb means „mixed“ not „splattered“!

The kwb mixing paddles are „Made in Germany“ and that signifies highest quality and the most modern production techniques. All mixers undergo a continuous quality assessment, because only with exactly the right mixer will you end up with the perfect mix.

Strong welded joints.

The patented construction of the mixers gives clean mixing- whatever material you need to deal with.

Peripheral protection ring

Guarantees smooth and safe running and prevents damage to the mixture container.

Powder coated surfaces

Impurity-free coating on edges and surfaces gives an attractive appearance and a pleasant feel. The manufacturing process is naturally environmentally friendly and carbon neutral.

... always the appropriate accessories for your machine!

HOLESAWS

Hollow core drills
Bi-metal holesaws
Diamond holesaws
Tungsten steel holesaws
Multi-blade holesaws



Holesaws



The benefits of holesaws / hollow core drills

- Hollow core drills for holes for concealed electrical wiring, sockets and junction boxes, downlighters and pipe holes through walls
- Holesaws in a variety of types such as Bi-metal, diamond, tungsten carbide gritted, tungsten steel, hardened tips

Programme overview holesaws / hollow core drills



Hollow core drills

★★★★★

Either tungsten- or diamond tipped core drills for drilling for concealed electrical wiring and pipe holes through walls, for use in all rotary and impact drills.

CAUTION: Use rotary action ONLY for diamond core drills!

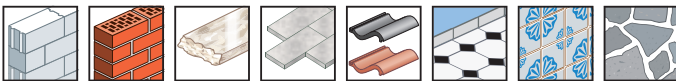

Page 128



HSS Bi-metal holesaws

★★★★★

HSS Bi-metal holesaws for metal, aluminium and composite boards, for use in all rotary and impact drills.

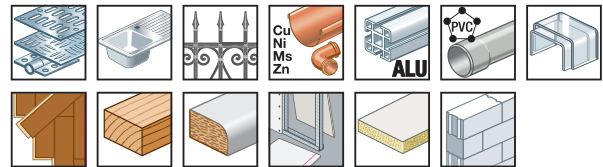

Page 129 - 131



Diamond holesaws

★★★★★

Diamond holesaws for porcelain and hard tiles, for drilling fixing holes, water pipes, waste pipes, junction boxes and sockets.

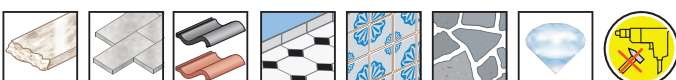

Page 132 - 133



Tungsten carbide gritted holesaws

★★★★★







Tungsten carbide gritted holesaws for wood, plastics, aerated concrete blocks. For installation work for switches and sockets and pipes.



Page 134 - 135

Holesaws / hollow core drills

Which holesaw diameter is for which job?

Application/use	Holesaw diameter (Ø mm)
 Water waste/-supply pipes Electrical conduit	12, 14, 16, 20, 25, 30
 Downlighters/ lamps	35, 40, 43, 51, 53, 57, 60, 63, 73, 74, 78, 83, 85, 92, 10, 103
 Water pipes through walls	35, 40, 51, 57, 60, 83, 85
 Sockets	65, 67, 68
 Junction boxes	68, 83, 85
 Switches	68



Tungsten steel holesaws

★★★★★

Tungsten steel holesaws for wood, chipboard and plastics, to make holes for downlighters, electrical cavity boxes and sockets and pipes through walls.

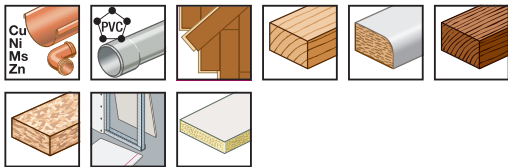

Page 136



Multiblade holesaws

★★★★★

Various patterns with or without hardened teeth, for wood, hardwood, chipboard, plasterboard, lightweight building materials and plastics.

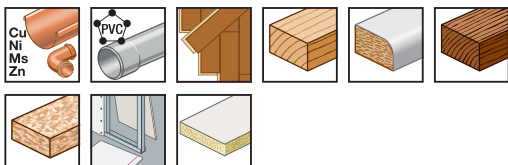

Page 137 - 140

kwb-Info

A safer job



It's always a good idea to wear protective gloves when your hands could possibly be injured, for example in building work with sharp-edged objects etc. For all types of work, a safe grip and wearer comfort are the prime requirements for the correct type of glove.

You can find all the relevant information in our **Personal Protection catalogue**, or on the Internet at www.kwb.eu.



Which holesaw to use with which material?

Kwb holesaws are suitable for a wide range of materials. Density, texture and thickness all come into play when selecting the right holesaw.

Holesaw range	Page	Quality	Metal	Stainless steel (INOX)	Cast iron	Non-ferrous metal	Aluminium	Plastics	Acrylic	Laminates
HOLLOW CORE DRILLS										
1751- Hollow core drills CARBIDE Ø 66 mm und Ø 80 mm	128	★★★★★								
1752- Hollow core drills DIAMOND Ø 68 mm und Ø 82 mm	128	★★★★★								
ONE-PIECE HOLESAWS										
598- HSS-Bi-Metall Variable tooth pitch Ø 16 mm bis Ø 152 mm	129	★★★★★	✓✓✓	✓✓	✓	✓✓✓	✓✓✓	✓	✓	✓
4998- Diamond holesaws Ø 5 mm bis Ø 35 mm und Ø 45 mm bis Ø 76 mm	132	★★★★★								
4994- tungsten carbide gritted Ø 33 bis Ø 103 mm	134	★★★★★						✓		
4993- Wolframstahl, tooth tips hardened Ø 35 bis Ø 100 mm	136	★★★★★				✓		✓✓		✓
498100 hardened Ø 65 mm	138	★★★★						✓		
498200 hardened Ø 68 mm	138	★★★★						✓		
499000 hardened Ø 80 mm	138	★★★★						✓		
MULTIBLADE HOLESAWS										
498300 Tooth tips hardened, 3-pcs. Ø 60, 67, 74 mm	137	★★★★★				✓		✓✓		✓
498800 Tooth tips hardened, 6-pcs. Ø 46, 53, 60, 68, 74, 81 mm	137	★★★★★				✓		✓✓		✓
498700 Tooth tips hardened, 7-pcs. Ø 46, 53, 59, 66, 73, 82, 94 mm	137	★★★★★				✓		✓✓		✓
499700 Tooth tips hardened, 5-pcs. Ø 69, 74, 80, 90, 100 mm	138	★★★★★				✓		✓✓		✓
498900 hardened, 8-pcs. Ø 25, 32, 38, 44, 51, 57, 63, 68 mm	139	★★★★						✓		
498500 hardened, 5-pcs. Ø 28, 35, 50, 68, 75 mm	139	★★★★						✓		
599000 Cutting depth 18 mm, 7-pcs. Ø 25, 32, 38, 45, 50, 58, 63 mm	139	★★★								
599100 Cutting depth 50 mm, 7-pcs. Ø 25, 32, 38, 45, 50, 58, 63 mm	140	★★★								















Holesaws / hollow core drills

The table gives advice on the suitability of the holesaws for use in:

GOOD = ✓

BETTER = ✓ ✓





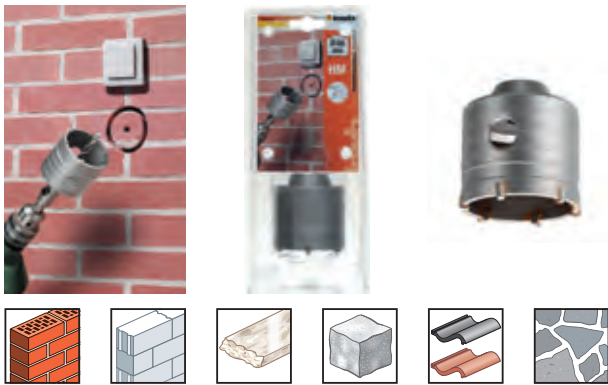

BEST = ✓ ✓ ✓

														
Softwood	Laminated boards	Hardwood	Chipboard	Plasterboard	Lightweight building materials	Aerated concrete blocks	Stone	Marble	Porcelain stone-ware	Roof tiles	Floor tiles	Wall tiles	Natural stone	Granite
						✓✓✓	✓✓✓	✓✓✓		✓✓			✓✓	✓
						✓✓✓	✓✓✓	✓✓	✓✓	✓✓✓	✓	✓	✓✓	
✓	✓			✓	✓✓	✓								
								✓✓	✓✓✓	✓✓	✓✓✓	✓✓✓	✓✓	
				✓		✓✓✓	✓				✓✓✓	✓✓✓	✓✓	
✓✓✓	✓✓✓	✓✓✓	✓✓✓	✓✓✓	✓									
✓✓✓	✓✓	✓✓	✓✓	✓✓✓										
✓✓✓	✓✓	✓✓	✓✓	✓✓✓										
✓✓✓	✓✓	✓✓	✓✓	✓✓✓										
✓✓✓	✓✓✓	✓✓✓	✓✓✓	✓✓✓	✓									
✓✓✓	✓✓✓	✓✓✓	✓✓✓	✓✓✓	✓									
✓✓✓	✓✓✓	✓✓✓	✓✓✓	✓✓✓	✓									
✓✓✓	✓✓	✓✓	✓✓	✓✓✓										
✓✓✓		✓		✓✓										
✓✓✓		✓		✓✓										

Core drills, tungsten carbide tipped







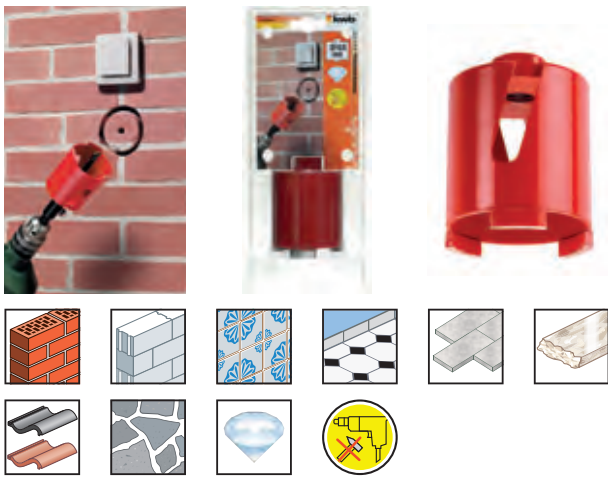

Tungsten carbide tipped hollow core drills, impact resistant, specially hardened, specially brazed heat resistant carbide plates, for use in masonry, stone, reconstituted stone, concrete, marble and brick, for fitting electrical sockets and waste pipes.

Art.-No.	Ø mm	for			Barcode
175166	66	175300 / 20		1	
175180	80	175300 / 20		1	

Diamond core drills









Hollow diamond core drills, segmented, laser welded segments for extra breakage resistance, quick clean cutting, extremely long life, fatigue-free operation, for use in masonry, stone, reconstituted stone, marble, tiles, porcelain, ceramics and brick, for fitting electrical sockets and waste pipes







Art.-No.	Ø mm	for			Barcode
175268	68	175300 / 20		1	
175280	82	175300 / 20		1	

Mandrel with pilot drill



Arbor with pilot drill, shanks 12mm hexagon and SDS Plus, M16 thread, for hollow core drills, tungsten carbide or diamond tipped, for use in all rotary and impact drills.















































































Art.-No.	for	Thread		mm			Barcode
Adaptor 12mm hex							
175300	175166 / -80, 175268 / -80, 175068 / -80	M 16		SW 12		1	

Art.-No.	for	Thread		mm			Barcode
Adaptor SDS plus							
175320	175166 / -80, 175268 / -80, 175068 / -80	M 16		SDS Plus		1	



Holesaws HSS bi-metal



Art.-No.	Ø mm	Cutting depth			Barcode
598016	16	32		1	
598019	19	32		1	
598020	20	32		1	
598022	22	32		1	
598025	25	32		1	
598030	30	32		1	
598032	32	32		1	
598035	35	32		1	
598038	38	32		1	
598040	40	32		1	
598041	41	32		1	
598044	44	32		1	
598046	46	32		1	
598048	48	32		1	
598051	51	32		1	
598054	54	32		1	
598057	57	32		1	
598060	60	32		1	
598064	64	32		1	
598065	65	32		1	
598067	67	32		1	
598068	68	32		1	
598070	70	32		1	
598073	73	32		1	
598076	76	32		1	
598079	79	32		1	
598083	83	32		1	
598089	89	32		1	
598092	92	32		1	
598095	95	32		1	
598102	102	32		1	
598105	105	32		1	
598108	108	32		1	
598111	111	32		1	
598114	114	32		1	
598121	121	32		1	
598127	127	32		1	
598152	152	32		1	

HSS bi-metal holesaws, progressive variable tooth pitch, for ultimate chip removal, HSS teeth 5% cobalt alloyed, extremely free running, long working life, for steel, castings, RSJs, stainless sheet, aluminium, bronze, copper, plastics, acrylic, plasterboard and wood.

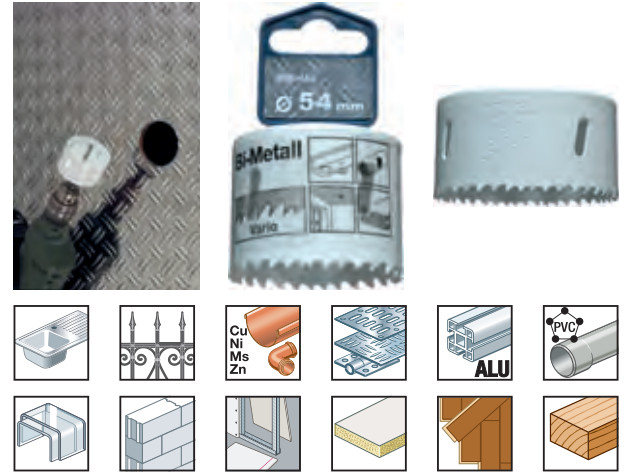

Mandrel for HSS bi-metal holesaws, Ø 16 - 30 mm ★★★★★

Mandrel for HSS Bi-metal holesaws, with HSS pilot drill



Art.-No.	for holesaws Ø mm	mm			Barcode
598800	16-30	6		1	4 009315 988009
598400	16-30	SDS Plus		1	4 009315 984001

Mandrel for HSS bi-metal holesaws, Ø 32 - 152 mm ★★★★★

Mandrel for HSS Bi-metal holesaws, specially hardened SDS-Plus shank, with HSS pilot drill



Art.-No.	for holesaws Ø mm	mm			Barcode
598900	32-152	6		1	4 009315 989006
598500	32-152	SDS Plus		1	4 009315 985008

Pilot drill HSS for HSS Bi-metal holesaws ★★★★★

HSS pilot drill for HSS Bi-metal holesaws



Art.-No.	Ø mm	Length	mm			Barcode
598700	6,35	100	6-kant		1	4 009315 987002

Holesaw set HSS bi-metal, 8-piece



Art.-No.	Ø mm	Cutting depth			Barcode
598200	20, 29, 35, 40, 51, 68	32		1	

HSS bi-metal holesaw set, progressive variable tooth pitch, for ultimate chip removal, HSS teeth 5% cobalt alloyed, extremely free running, long working life, for steel, castings, RSJs, stainless sheet, aluminium, bronze, copper, plastics, acrylic, plasterboard and wood. 2 mandrels for HSS bi-metal holesaws, specially hardened hexagon shanks, with HSS pilot drills.

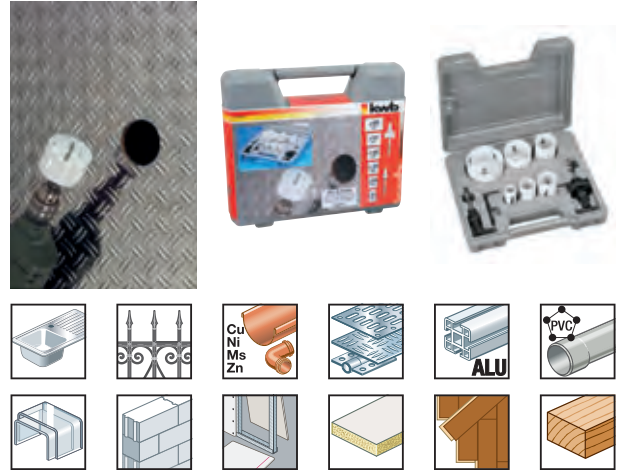

HSS Bi-metal holesaws, with mandrel and pilot drill



Art.-No.	Ø mm	Cutting depth			Barcode
598520	20	38		1	
598522	22	38		1	
598525	25	38		1	
598529	29	38		1	
598532	32	38		1	
598535	35	35		1	
598540	40	38		1	
598545	45	38		1	
598551	51	38		1	
598556	56	38		1	
598565	65	38		1	
598568	68	38		1	
598574	74	38		1	
598583	83	38		1	

HSS Bi-metal holesaws, with mandrel and pilot drill, variable tooth pitch for faster chip removal, HSS teeth, friction reducing, excellent working life, for steel, castings, RSJs, sheet steel, aluminium, bronze, copper, plastics, acrylic, plasterboard and wood.

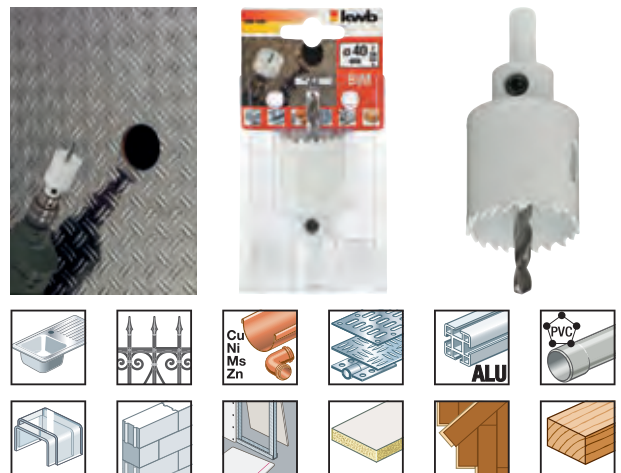





































Diamond coated holesaws



Diamond particle coated holesaws, high quality industrial diamond, for use even on the hardest tiles, unitary body construction, accurate, highly concentric, 5 to 35 mm for wallplug holes, water pipes, waste pipes and 45 to 82 mm for waste pipes, electrical boxes and sockets, for porcelain, granite worktops, tiles, quarry tiles, ceramics, natural stone slabs, marble.



Art.-No.	Ø mm	Cutting depth			Barcode
for wall plug holes, plumbing fittings and water pipes					
499805	5	25		1	
499806	6	25		1	
499807	7	25		1	
499808	8	25		1	
499810	10	25		1	
499812	12	25		1	
499814	14	25		1	
499816	16	25		1	
499820	20	25		1	
499825	25	25		1	
499830	30	25		1	
499835	35	25		1	





Art.-No.	Ø mm	Cutting depth			Barcode
for sewage pipes, junction boxes and electrical sockets					
499845	45	25		1	
499850	50	25		1	
499868	68	25		1	
499876	76	25		1	

Water feed system and drill guide



Water feed system and drilling guide, for diamond holesaws from 5 to 35 mm.



Art.-No.	for holesaws Ø mm			Barcode
499800	5 - 35		1	

Holesaws

Drilling guide for diamond coated holesaws



Drilling guide for diamond holesaws, from 40 to 82 mm, use together with water feed system kwb part no. 499802

Art.-No.	for holesaws Ø mm			Barcode
499801	45 - 82		1	



Water feed system with hose for diamond hole-saws



Water feed system with hose for diamond holesaws, for use with drilling guide, kwb part no. 449801





Art.-No.	for			Barcode
499802	499801		1	



Diamond holesaw set, 8-piece



Diamond holesaw set, 8-piece, 7 diamond coated holesaws, high quality industrial diamond, for use in even the hardest tiles, one-piece drawn body, accurate, highly concentric, for fixing holes, supplied with drilling guide with suction cup and connection for water feed, for porcelain, granite worktops, tiles, quarry tiles, ceramics, stone flags, marble worktops.

Art.-No.	Contents			Barcode
499900	Ø 4, 5, 6, 7, 8, 10, 12 + Diamond drill bit set with drill guide		1	



Holesaw, tungsten carbide gritted, complete with arbor and pilot drill

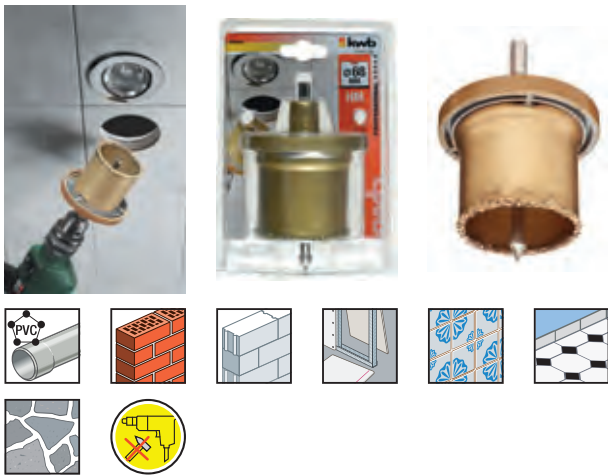

Holesaw, tungsten carbide gritted, complete with arbor and pilot drill, precision tube, coated with special tungsten carbide grit, high temperature brazed, for aerated concrete blocks, masonry, tiles, ceramics, natural stone, lightweight building materials, plasterboard and plastics, for installers, eg. switches and sockets, water pipes.

Art.-No.	Ø mm	Cutting depth			Barcode
499460	68	55		2	
499480	83	55		2	

Holesaw, tungsten carbide gritted

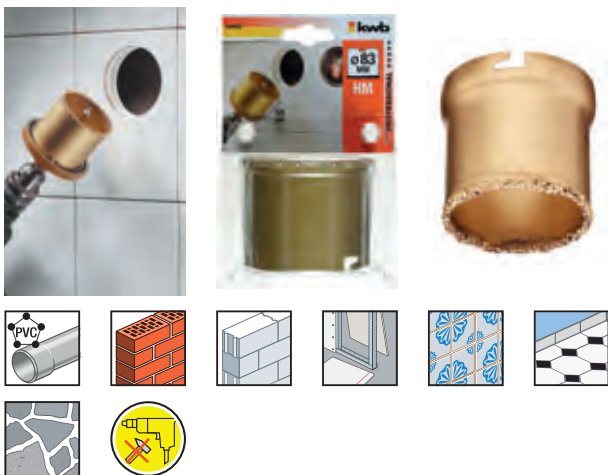

Holesaw, tungsten carbide gritted, precision formed body, coated with special tungsten carbide grit, high temperature brazed, for aerated concrete blocks, masonry, tiles, ceramics, natural stone, lightweight building materials, plasterboard and plastics, for installation work eg fitting switches, sockets and pipes.

Art.-No.	Ø mm	Cutting depth			Barcode
499403	33	55		2	
499404	43	55		2	
499405	53	55		2	
499406	63	55		2	
499426	67	55		2	
499407	73	55		2	
499408	83	55		2	
499450	103	55		2	

Arbor for tungsten carbide gritted holesaws



Arbor for tungsten carbide gritted holesaws

Art.-No.	for holesaws Ø mm			Barcode
499420	33 - 83		2	
499430	70 - 103		2	

Holesaws

Pilot drill for tungsten carbide gritted holesaws



Pilot drill for tungsten carbide gritted holesaws, to fit all tungsten carbide tipped holesaws, special drill bit for an easy start without slippage.



Art.-No.	Ø mm			Barcode
499410	9		1	



Tungsten carbide gritted holesaw set, 7-piece



Holesaw set, tungsten carbide gritted, 5 holesaws, precision tube body, coated with special carbide grit, high temperature brazed, for lightweight blocks, masonry, tiles, slate, ceramics, natural stone, lightweight building materials, plasterboard and plastics, for installation work eg sockets, junction boxes, pipe laying, with pilot drill and arbor.

Art.-No.	Contents			Barcode
499507	33, 53, 67, 71, 83 Arbor, Pilot drill		1	

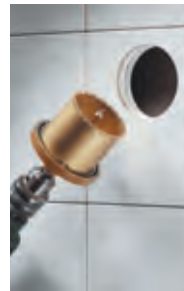

kwb-Info

A safer job

Our eyes, as one of the most important sensory organs, must always be protected while working. That's why kwb has put together for all common situations when drilling, shaping, grinding or welding indoors or outdoors, a high quality protective eyewear range also suitable for spectacle-wearers.







You can find all the relevant information in our **Personal Protection catalogue**, or on the Internet at **www.kwb.eu**.



Tungsten steel holesaw, with mandrel and pilot drill



























Tungsten steel holesaw with shank and pilot drill, sheet steel arbor, hardened tungsten steel teeth, screwed tightly to the arbor, fine tolerances, for wood, laminated boards, hardwood, blockboard, plasterboard, lightweight building materials, plastics and copper, for installing downlighters, sockets, junction boxes and water pipes.

Art.-No.	Ø mm	Cutting depth			Barcode
499300	68	40		1	
499303	68, 83, 100	40		1	

Tungsten steel holesaw







Tungsten steel holesaw, sheet steel arbor, hardened tungsten steel teeth, screwed tightly to the arbor, fine tolerances, for wood, laminated boards, hardwood, blockboard, plasterboard, lightweight building materials, plastics and copper, for installing downlighters, sockets, junction boxes and water pipes.

Art.-No.	Ø mm	Cutting depth			Barcode
blister packed					
499335	35	40		1	
499340	40	40		1	
499352	51	40		1	
499357	57	40		1	
499360	60	40		1	
499368	68	40		1	
499374	74	40		1	
499378	78	40		1	
499383	83	40		1	
499392	92	40		1	
499399	100	40		1	

Mandrel for tungsten steel hole saws



Mandrel for tungsten steel holesaws, specially hardened hexagon shank, with HSS pilot drill.

Art.-No.	Ø mm	 mm			Barcode
Adaptor 10mm hex					
499310	5	● 10		1	

Holesaws

Holesaw set, interchangeable blades, 3-piece



Holesaw, 3 blades, heavy zinc alloy arbor, hardened spring steel teeth, teeth induction hardened, for use in wood, laminated boards, hardwoods, blockboard, plasterboard, lightweight building materials, plastics and copper.

Art.-No.	Ø mm	Cutting depth			Barcode
498300	60, 67, 74	30		4	



Holesaw set, interchangeable blades, 6-piece



Holesaw, 6 blades, heavy zinc alloy arbor, hardened spring steel teeth, teeth induction hardened, for use in wood, laminated boards, hardwoods, blockboard, plasterboard, lightweight building materials, plastics and copper.

Art.-No.	Ø mm	Cutting depth			Barcode
498800	46, 53, 60, 68, 74, 81	32		2	



Holesaw set, interchangeable blades, 7-piece



Holesaw, 7 blades, heavy zinc alloy arbor, hardened spring steel teeth, teeth induction hardened, for use in wood, laminated boards, hardwoods, blockboard, plasterboard, lightweight building materials, plastics and copper.

Art.-No.	Ø mm	Cutting depth			Barcode
498700	46, 53, 59, 66, 73, 82, 94	30		2	

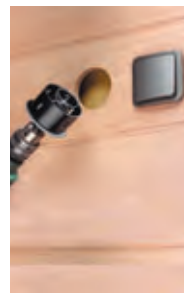

Holesaw set, interchangeable blades, 5-piece



Holesaw, 5 blades, heavy zinc alloy arbor, hardened spring steel teeth, teeth induction hardened, for use in wood, laminated boards, hardwoods, blockboard, plasterboard, lightweight building materials, plastics and copper.

Art.-No.	Ø mm	Cutting depth			Barcode
499700	68, 74, 80, 90, 100	32		2	4 009314 997002

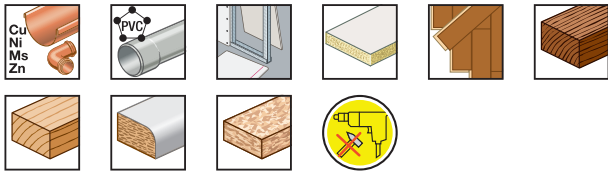

Holesaws, 1-piece



Holesaw, one-piece, heavy zinc alloy arbor, hardened spring steel teeth, for use in wood, boards, plasterboard and lightweight building materials

Art.-No.	Ø mm	Cutting depth			Barcode
498100	65	28		4	4 009314 990005
498200	68	28		4	4 009314 982008

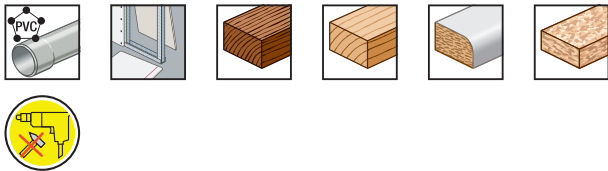

Holesaws, single blade

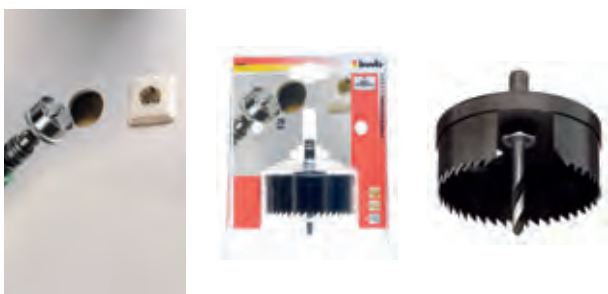

Holesaw, one-piece, heavy zinc alloy arbor, hardened spring steel teeth, for use in wood, boards, plasterboard and lightweight building materials

Art.-No.	Ø mm	Cutting depth			Barcode
499000	80	28		4	4 009314 990005

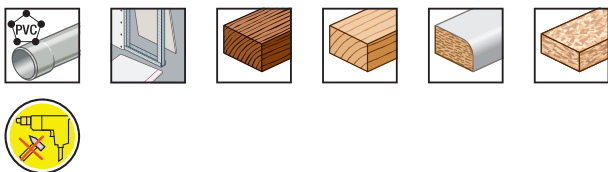





Holesaws

Holesaw set, interchangeable blades, 8-piece

★★★★

Holesaw, 8 blades, heavy zinc alloy arbor, hardened spring steel teeth, for use in wood, boards, plasterboard and lightweight building materials



Art.-No.	Ø mm	Cutting depth			Barcode
498900	25, 32, 38, 44, 51, 57, 63, 68	28		4	



Holesaw set, interchangeable blades, 5-piece

★★★★

Holesaw, 5 blades, heavy zinc alloy arbor, hardened spring steel teeth, for use in wood, boards, plasterboard and lightweight building materials





Art.-No.	Ø mm	Cutting depth			Barcode
498500	28, 35, 50, 68, 75	30		2	



Holesaw set, interchangeable blades, 7-piece

★★★

Holesaw, 7 blades, die-cast aluminium arbor, hardened spring steel teeth, for use in wood, boards, plasterboard and lightweight building materials.

Art.-No.	Ø mm	Cutting depth			Barcode
599000	25, 32, 38, 45, 50, 58, 63	18		4	



Holesaw set, interchangeable blades, 7-piece



Holesaw, 7 blades, die-cast aluminium arbor, hardened spring steel teeth, for use in wood, boards, plasterboard and lightweight building materials.

Art.-No.	Ø mm	Cutting depth			Barcode
599100	25, 32, 38, 45, 50, 58, 63	40		4	4 009315 991009

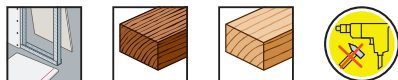

Holesaw set, 4-piece, for cordless tools



With cordless shank 1/4" E 6.3 specially for cordless drivers, BOSCH UNEO and mini cordless drivers such as BOSCH IXO. Ideal for making holes for downlighters.

Art.-No.	Ø mm			Barcode
497900	26, 35, 40, 52			4 009314 979008

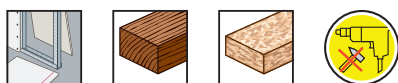



BRUSHES

AGGRESSO POWER brushes

HSS steel wire brushes

Brass brushes

Stainless steel brushes

Nylon abrasive brushes

Brushes



The benefits of brushes

- For use in standard drills
- Fast working and comprehensive cleaning of masonry, removal of rust and paint
- Clean polishing
- Deburring
- Smoothing sharp edges
- Offered made from HSS steel wire, brass, stainless steel or nylon

Programme overview brushes



AGGRESSO POWER ★★★★★ Brushes

Highly flexible, protect the base material, for derusting, descaling, removal of paints and thick surface coatings, cleaning of masonry, plaster residue and concrete surfaces.

Page 144



HSS steel wire ★★★★★ brushes

HSS steel brushes for use in all rotary and impact drills. For derusting and cleaning, removal of paint, descaling and deburring.

Page 145 - 148



Brass brushes ★★★★★

Brass brushes for all fine sanding and polishing jobs on metal, high corrosion protection.

Page 149



Stainless steel brushes ★★★★★

Stainless steel brushes for derusting, cleaning, deburring of stainless steel and all metals and outdoor woodwork. No rust marks left.

Page 149



Nylon abrasive brushes ★★★★★

Nylon abrasive brushes for cleaning and removal of paint and varnish, non-aggressive polishing of wood, metal, alloys and non-ferrous metals.

Page 150

Important safety advice

For efficient and safe working you should select the maximum possible diameter brush that can be fitted to the drive unit. From the brush diameter the relevant rotation speed can be determined to get the best performance from the brush. The table opposite gives an overview.

Fitting advice

Please check before fitting the brush:

- The speed of rotation of your machine must not exceed the maximum safe rotation speed of the brush
- The brush must be fitted so that it sits firmly against the spindle nut
- Brushes with projecting spindle can easily be fitted to standard chucks or tool holders
- The high speed brushes are provided with spanner flats for easy fitting and removal

Safe rotation speeds:

As a guide for determining safe rotation speed you can take approx. 30-35 metres/second for crimped wire brushes, 18-22 metres/second for brushes with abrasive filaments and plastic sheathed bristles. Brushes with twist knot wire can be used on angle grinders at up to 85 metres/second, or 45 metres/second on stationary machines.

Important: Hand held power tools must never be used with brushes exceeding 180 mm in diameter.

UPM min ⁻¹	Brush diameter in mm											
	20	40	50	80	100	125	150	180	200	250	300	350
Peripheral rotation speed in metres per second												
800				3,35	4,19	5,23	6,28	7,53	8,37	10,47	12,56	14,75
900			2,35	3,77	4,71	5,88	7,06	8,48	9,41	11,77	14,12	16,47
1.150			3,01	4,81	6,01	7,52	9,02	10,83	12,03	15,04	18,04	21,04
1.200	1,25	2,51	3,14	5,02	6,28	7,85	9,41	11,30	12,55	15,69	18,83	21,97
1.400	1,46	2,93	3,66	5,86	7,32	9,15	10,98	13,18	14,64	18,31	21,97	25,63
1.500	1,57	3,14	3,92	6,28	7,85	9,81	11,77	14,13	15,69	19,61	23,54	27,46
1.800	1,88	3,77	4,71	7,54	9,41	11,77	14,12	16,95	18,83	23,54	28,24	32,95
2.000	2,09	4,19	5,23	8,37	10,26	13,08	15,69	18,84	20,92	26,15	31,38	36,61
2.500	2,62	5,23	6,54	10,47	13,08	16,35	19,61	23,55	26,15	32,67	39,23	45,76
2.800	2,93	5,86	7,32	11,72	14,64	18,31	21,97	26,37	29,29	36,61	43,93	51,25
3.000	3,14	6,28	7,85	12,56	15,69	19,62	23,54	28,26	31,38	39,23	47,07	54,92
3.200	3,35	6,70	8,37	13,40	16,74	20,92	25,10	30,14	33,47	41,84	50,12	58,58
3.500	3,66	7,33	9,15	14,65	18,31	22,89	27,46	32,97	36,61	45,76	54,92	64,07
4.000	4,19	8,37	10,46	16,75	20,92	26,16	31,38	37,68	41,84	52,33	62,76	73,22
4.500	4,70	9,42	11,77	18,84	23,54	29,43	35,30	42,40	47,07	58,84	70,61	82,43
5.000	5,23	10,47	13,08	20,93	26,15	32,70	39,23	47,10	52,33	65,38	78,50	
5.400	5,65	11,30	14,12	22,94	28,24	35,31	42,36	50,67	56,48	70,61	84,78	
6.000	6,28	12,56	15,69	25,12	31,38	39,24	47,07	56,52	62,76	78,50		
7.000	7,33	14,66	18,31	29,31	36,61	45,78	54,92	65,94	73,22	91,58		
8.000	8,37	16,75	20,92	33,94	41,48	52,32	62,76	75,36	83,73			
9.000	9,42	18,84	23,54	37,68	47,07	58,86	70,61	84,78	94,20			
10.000	10,47	20,93	26,17	41,86	52,33	65,40	78,50	94,20				
12.500	13,08	26,17	32,71	52,33	65,42	81,75	98,13					
15.000	15,70	31,40	39,25	62,80								
17.500	18,32	36,63	45,79	73,26								
20.000	20,93	41,87	52,33	83,73								
22.500	23,55	47,10	58,88	94,20								
25.000	26,17	52,33	65,42	104,66								

Bristle material: the best material for each job

HSS steel wire, crimped / twist knot

- High speed steel wire with high tensile strength
- High resistance to breakage and long working life
- For extreme applications

Stainless steel wire, crimped

- Normal alloying 1,4310 (1.4401/1.4571 on request)
- Use when remnants of normal wire would otherwise mark the work surface

Brass wire, crimped

- Surface finishing on copper and brass

Brass-plated steel wire, crimped

- Individual strands
- High tensile strength
- For demanding brushing and deburring jobs

Abrasive brushes, aluminium oxide, crimped

- With aluminium oxide coated nylon filaments
- Consistent abrasive action through gradual release of abrasive
- High flexibility without risk of breakage
- Hard-wearing
- For deburring/derusting, roughing up and sanding

AGGRESSO POWER Universal wire brush set



AGGRESSO POWER stripping brush set, consisting of arbor, brush belt and hexagon key. U-shaped hooked steel wire, cropped ends, mounted on flexible brush belt, highly flexible, excellent for surface work, for derusting, descaling, slag removal, paint and varnish removal, thick surface coatings, cleaning of masonry, plaster residue removal, heavy duty cleaning of concrete surfaces and formwork.

Art.-No.	Ø mm			Barcode
602500	110		1	4 009316 025000

AGGRESSO POWER Wire stripping brush set



AGGRESSO POWER stripping brush set, consisting of arbor, brush belt and hexagon key. U-shaped hooked steel wire, cropped ends, mounted on flexible brush belt, highly flexible, excellent for surface work, for derusting, paint and varnish removal, thick surface coatings, cleaning of masonry, plaster residue removal, cleaning concrete surfaces and formwork.

Art.-No.	Ø mm			Barcode
602600	110		1	4 009316 026007

kwb-Info

A safer job

Many jobs will generate dust and particles, or vapours and gases, or will involve working with potentially harmful substances. Protect your lungs and airways against these hazards! This is why kwb has put together a comprehensive range of protective masks, with and without breather valves.

For all standard applications in the prescribed breathing protection categories.

You can find all the relevant information in our **Personal Protection catalogue**, or on the Internet at **www.kwb.eu**.









Brushes

Wheel brush, HSS steel wire, crimped



Wheel brush, HSS steel wire, crimped, for derusting, cleaning, paint, scale, encrustation and ridges, for metal and stone, ideal for work on narrow edges, frames, posts, grilles and pipes.

Art.-No.	Wire	Wire Ø mm	Ø mm	mm			Barcode
display box							
607310	fine	0,2	75	6		6	
607330	coarse	0,35	75	6		6	
607410	fine	0,2	100	6		6	
607430	coarse	0,35	100	6		6	



Art.-No.	Wire	Wire Ø mm	Ø mm	mm			Barcode
bulk in dump bin							
607333	coarse	0,35	75	6		Z25	
607433	coarse	0,35	100	6		Z15	





Wheel brush, double thickness, HSS steel wire, crimped



Wheel brush, HSS steel wire, crimped, for derusting, cleaning, paint, scale, encrustation and ridges, for metal and stone, ideal for work on narrow edges, frames, posts, grilles and pipes.

Art.-No.	Wire	Wire Ø mm	Ø mm	mm			Barcode
display box							
607830	coarse	0,3	75	6		6	
607930	coarse	0,3	100	6		6	

Art.-No.	Wire	Wire Ø mm	Ø mm	mm			Barcode
bulk in dump bin							
607833	coarse	0,3	75	6		Z20	
607933	coarse	0,3	100	6		Z10	



Wheel brush, extra strong, HSS steel wire, twist knot



Wheel brush, HSS steel wire, twist knot, for extremely heavy jobs derusting, removing paint, clinker, scale and removing welding marks, for metal and wood, ideal for use on narrow edges, frames, posts, gratings and tubes.

Art.-No.	Wire	Wire Ø mm	Ø mm	mm			Barcode
603030	coarse	0,5	70	6		6	4 009316 030301

Cup brush, HSS steel wire, crimped

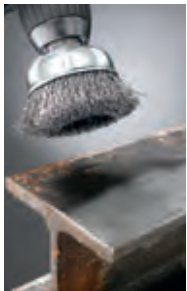

Cup brush, HSS steel wire, crimped, for derusting, cleaning, surface coating and paint removal, cleaning frameworks and facades, descaling, levelling, roughing up and matting, for metal and stone, ideal for working medium to large areas.

Art.-No.	Wire	Wire Ø mm	Ø mm	mm			Barcode
display box							
606210	fine	0,2	50	6		6	4 009316 062104
606230	coarse	0,3	50	6		6	4 009316 062302
606310	fine	0,2	75	6		6	4 009316 063101
606330	coarse	0,3	75	6		6	4 009316 063309



Art.-No.	Wire	Wire Ø mm	Ø mm	mm			Barcode
bulk in dump bin							
606233	coarse	0,3	50	6		Z25	4 009316 062333
606333	coarse	0,3	75	6		Z15	4 009316 063330

Cup brush, extra heavy duty, HSS steel wire, crimped

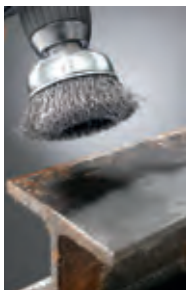

Cup brush, extra heavy duty, HSS steel wire, crimped, for derusting, cleaning, surface coating and paint removal, cleaning frameworks and facades, descaling, levelling, roughing up and matting, for metal and stone, ideal for working medium to large areas.

Art.-No.	Wire	Wire Ø mm	Ø mm	mm			Barcode
display box							
602430	coarse	0,35	75	6		6	4 009316 024300

Brushes

Cup brush, extra heavy duty, HSS steel wire, crimped



Art.-No.	Wire	Wire Ø mm	Ø mm	mm			Barcode
bulk in dump bin							
602433	coarse	0,35	75	6		Z10	



Tight Corner End Brush, HSS steel wire, crimped



Tight corner end brush, HSS steel wire, crimped, for derusting, cleaning, removal of surface coatings, paint and excess rubber, descaling, smoothing, roughing up and matt finishing, for metal and stone, ideal for working with difficult shapes and interior surfaces, eg cast iron gates, grilles, gratings etc.

Art.-No.	Wire	Wire Ø mm	Ø mm	mm			Barcode
display box							
608030	coarse	0,3	25	6		6	



Art.-No.	Wire	Wire Ø mm	Ø mm	mm			Barcode
bulk in dump bin							
608033	coarse	0,3	25	6		Z24	



Rustic styling brush, brassed HSS wire



Rustic styling brush, brassed HSS steel wire for corrosion resistance, crimped, for rust removal, cleaning, paint, scale, encrustation removal and surface levelling, also especially designed for giving a rustic appearance to roof timbers; for metal and wood, ideal for working on edges, frames, posts, bars, pipes and fairly large areas.

Art.-No.	Working width	Wire Ø mm	Ø mm	mm			Barcode
display box							
604030	40	0,27	80	8		3	







Art.-No.	Working width	Wire Ø mm	Ø mm	mm			Barcode
bulk in dump bin							
604033	40	0,27	80	8		Z10	



Wire brush set, 4-piece, Steel wire, crimped







Wire brush set 4-piece, 3 wire brushes, steel wire, crimped, with arbor, for rust removal, cleaning, removing surface coatings and paint, cleaning weatherboards and facades, descaling, flattening, roughening and matting surfaces, for metal and masonry

Art.-No.	Wire Ø mm	Contents			Barcode
597500	0,3	1 Wire wheel brush Ø 75 mm 1 Cup brush Ø 50 mm 1 End brush Ø 15 mm 1 Arbor Ø 6 mm		6	 4 009315 975009

Wire brush set, 3-piece, HSS steel wire, crimped













Wire brush set, 3-piece, crimped, for fine work, for derusting, paint removal, cleaning and matt finishing, for use in mini-drill systems and flexible shafts, ideal for modelmaking.

Art.-No.	Wire Ø mm	Contents			Barcode
518000	0,1	1 Wire wheel brush Ø 22 mm 1 Cup brush Ø 18 mm 1 Corner end brush Ø 5 mm		6	 4 009315 180007



Tube/radiator brushes, steel wire, crimped



Tube and radiator brushes, steel wire, crimped, ideal for working inside pipes and large holes, radiators etc., for removing rust and paint, cleaning, descaling and surface leveling, for preparation for welding and brazing jobs, for metal and stone.

Art.-No.		Ø mm	Overall length			Barcode
display box						
599300	55	20	200		6	 4 009315 993003
599400	55	26	200		6	 4 009315 994000
599500	55	32	200		6	 4 009315 995007
599600	55	38	200		6	 4 009315 996004

Art.-No.	Contents			Barcode
bulk in dump bin				

599922	5x 13, 5x 20, 5x 26, 5x 32, 4x 38mm Ø		24	 4 009315 999227
--------	---------------------------------------	---	----	--

Brushes

Cup brush, brass wire, crimped



Cup brush, brass wire, corrosion-free, crimped, for fine work cleaning, paint removing, polishing and matt finishing, for metal and stone, ideal for working on medium sized areas

Art.-No.	Wire	Wire Ø mm	Ø mm	mm			Barcode
display box							
609110	fine	0,2	50	6		4	

Art.-No.	Wire	Wire Ø mm	Ø mm	mm			Barcode
bulk in dump bin							
609113	fine	0,2	50	6		Z20	



Wheel brush, brass wire, crimped



Wheel brush, brass wire, corrosion-free, crimped, for fine work cleaning, paint removing, polishing and matt finishing, for metal and stone, ideal for working on narrow edges, frames, gratings and tubes.

Art.-No.	Wire	Wire Ø mm	Ø mm	mm			Barcode
display box							
609310	fine	0,2	75	6		4	



Art.-No.	Wire	Wire Ø mm	Ø mm	mm			Barcode
bulk in dump bin							
609313	fine	0,2	75	6		Z15	



Wheel brush, stainless steel wire, crimped



Wheel brush, stainless steel wire, crimped, for derusting, cleaning, removal of surface coatings and paint, descaling, levelling, roughin up and matting, for stainless steel, metal, wood and stone, for working on narrow edges, frames, grilles, railings and pipes, ideal for all outside jobs, doesn't leave rust marks on the workpiece.

Art.-No.	Wire	Wire Ø mm	Ø mm	mm			Barcode
609810	fine	0,2	75	6		4	
609830	coarse	0,3	75	6		4	



Cup brush, nylon



Cup brush, nylon, aluminium oxide abrasive, flexible, for fine sanding, for cleaning, removing paint, varnish and welding discolouration, on stainless steel, for wood, metal, light alloy, non-ferrous metals, also suitable for surfacing wood, for working medium sized surfaces.

Art.-No.	Wire	Ø mm	⌈ mm			Barcode
603230	coarse	50	6		6	4 009316 032305
603330	coarse	75	6		6	4 009316 033302

Wheel brush, nylon



Wheel brush, nylon, aluminium oxide abrasive, flexible, for fine sanding, for cleaning, removing paint, varnish and welding discolouration, on stainless steel, for wood, metal, light alloy, non-ferrous metals, also suitable for surfacing wood, for working on narrow edges, frames, grilles and curved objects.

Art.-No.	Wire	Ø mm	⌈ mm			Barcode
604310	fine	75	6		6	4 009316 043106
604330	coarse	75	6		6	4 009316 043301
604430	coarse	100	6		6	4 009316 044308

Nylon Stripping Brush



Stripping brush, nylon, aluminium oxide abrasive, flexible, for fine sanding, for cleaning, removing paint, varnish and welding discolouration, on stainless steel, for wood, metal, light alloy, non-ferrous metals, also suitable for surfacing wood, for working flat surfaces.

Art.-No.	Wire	Ø mm	Sections	⌈ mm			Barcode
604630	fine	100	10	6		4	4 009316 046302



SANDING AND POLISHING

- Abrasive rolls**
- Sanding sheets**
- Sanding discs**
- Detail sander discs**
- Scouring pads**
- Orbital sander sheets**
- Mesh sanding sheets**
- Sanding belts**
- Sanding sponges**
- Steel wool**
- Hand sanders**
- Flap wheels**
- Polishing wheels and polishing bonnets**

Sanding and Polishing



The benefits of sanding and polishing media

- Wide variety of formats (rolls, sheets, discs, triangles, orbital sheets, belts)
- Different grades and grits to suit the desired material (see **Grades**)
- Flap wheels for working on both flat and curved objects
- Polishing wheels and bonnets for applying polishes and polishing various materials

Grades

Corundum, type WOOD AND METAL

Corundum, aluminium oxide coated, universal use for sanding wood, metal, paint, varnish, rust and filler
Grits from 40 (coarse) to 180 (fine)

Available as:

abrasive rolls, sanding sheets, sanding discs, detail sander sheets, orbital sander sheets, sanding sponges

Wet-and-dry, type PAINT AND CAR

Silicon carbide coated, wet and dry use, waterproof, especially flexible, high stock removal, long working life, especially fine grits for professional car refinishing, and for working on resin paint, varnish, paint, glass, stone, plastic and metal. Grits from 80 (coarse) to 1000 (extra fine).

Available as:

sanding sheets, sanding sponges

Finishing, type WOOD AND VARNISH

Special corundum, aluminium oxide coated, specially for hard- and softwood, phenolic resin, acrylic coatings, paint, varnish and plastics.
Grits from 40 (coarse) to 320 (fine).

Available as:

Sanding sheets

Silversand, type WOOD AND VARNISH

Silversand, corundum, aluminium oxide coated, stearate coated, reduces clogging, specially for hard- and softwoods, phenolic resin, acrylic coatings, paint, varnish and plastics.
Grits from 40 (coarse) to 240 (fine).

Available as:

sanding discs, detail sander discs

Blue emery cloth, type METAL AND PAINT

Emery, aluminum oxide coated, blue cloth backing, high quality woven reinforcement, flexible, extremely tear-resistant and low friction, universal product for working on metal and steel, for removing rust, scale, paint, varnish and resin.
Grits from 40 (coarse) to 240 (fine).

Available as:

Sanding sheets

Mesh sanding sheets, type FILLER AND PLASTERBOARD

Abrasive mesh sheet, fibreglass mesh with resin-bonded silicon carbide abrasive, through the open mesh structure especially suitable for smoothing of plaster, filler, paint, resin paint, acrylic coatings, rust and other materials where fine dust would clog normal abrasives.
Grits from 120 (medium) to 180 (fine).

Available as:

orbital sander sheets

kwb-Info

Always the right abrasive

Due to the vast variety of manufacturers of sanders it's sometimes not easy to find the correct abrasive. Our machine charts are classified by manufacturer and give a quick and clear overview showing which abrasive product fits your machine.

Sanding discs	Pages 160 - 161
Detail sander discs	Pages 168 - 169
Orbital sander sheets	Pages 176 - 179
Sanding belts	Pages 186 - 188



Flint, type WOOD AND PAINT

Quarz sand, economically priced and quick, standard sandpaper for sanding wood, paint and fillers. Grits from 40 (coarse) to 240 (fine).

Available as:
Sanding sheets

Sanding belts, type WOOD AND METAL

Special corundum, aluminium oxide coated, phenolic resin boned, heavy, flexible woven cloth backing, special glueing, suitable for universal sanding. Grits from 40 (coarse) to 240 (fine).

Available as:
Sanding belts

kwb-Info

A safer job

Particularly when working with electric sanders, such as belt sanders, dust and fine particles will be produced. Protect your airways against this, often invisible, threat. kwb has put together a comprehensive range of dust masks, with or without breather valve. For all standard applications in the prescribed breathing protection categories.



You can find all the relevant information in our **Personal Protection catalogue**, or on the Internet at www.kwb.eu.





Abrasive rolls

★★★★★

Corundum. For use with hand sanders, sanding blocks and all standard orbital sanders, pre-cut to the popular widths of 93 and 115mm. Simply cut off the desired length and use on the desired material.

Page 156



Sanding sheets

★★★★★

Corundum, finishing, blue emery cloth, wet-and-dry and flint. For use with hand sanders and sanding blocks, very flexible and handy, can be torn, cut or folded to the desired size. Packed 50 sheets to a pack for single sheet sales, with barcode label.

Page 157 - 159



Sanding discs

★★★★★

Corundum, Silversand, for universal sanding

with all popular mains and cordless drills: unpunched, with and without hook-and-loop fixing QUICK-STICK

for all popular random orbit sanders: punched with extraction holes for internal dust extraction, with QUICK-STICK hook-and-loop fixing system.

Page 162 - 167



Detail sander discs and special forms

★★★★★

Corundum and Silversand, for use with all popular delta and detail sanders, for sanding in corners and up to edges, unpunched or punched with extraction holes for internal dust extraction. With and without QUICK-STICK hook-and-loop fixing system.

Page 170 - 174



Scouring pads

★★★★★

Aluminium oxide abrasive, for use with delta sanders, for contouring and smoothing wood, removing rust from metal, and for roughing, for example matt finishing of varnish. With QUICK-STICK hook-and-loop fixing system.

Page 171 + 172



Orbital sander sheets

★★★★★

Corundum, for use with orbital sanders, ready cut to size in various grits for universal sanding, unpunched or punched with extraction holes for internal dust extraction. With and without QUICK-STICK hook-and-loop fixing system.

Page 180 - 184



Mesh sanding sheets

★★★★★

Lattice strips, sanding mesh, fibreglass body with resin-bonded silicon carbide abrasive, for use with hand sanders, specially for smoothing filler, plaster and Fermacell, removing paint, resin paint, acrylic coatings and rust.

Page 185



Sanding belts

★★★★★

Corundum, for use with belt sanders, sanding belts with high quality, flexible woven backing, extra smooth and true running, in various grits, for universal sanding on large surfaces.

Page 189 - 192

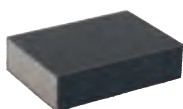

Sanding sponges

★★★★★

Silicon carbide or aluminium oxide coated, body made from highly flexible polyurethane foam, phenolic resin bonded, wet-and-dry use, especially good for sanding shaped surfaces, for removing rust and paint, cleaning and sanding in automotive and bike trades.

Page 193 - 194



Steel wool

★★★★★

Steel wool, rust resistant quality steel, highly tear-resistant, flexible, for polishing, matt finishing, fine sanding and cleaning of metal and wood.

Page 195

Programme overview sanding and polishing



Hand sanders

★★★★★

For use with sanding sheets, with spring clamps, for universal sanding particularly on small areas. Also available in natural cork.

Page 196 - 197



Fleece flap wheel

★★★★★

Corundum, combination head, with leaves of both sanding paper and abrasive fleece, suitable for all popular mains and cordless drills, for fine work on surfaces, matt- and satin finishing of metal, wood and plastics, especially good on surfaces and round objects.

Page 198



Flap discs

★★★★★

Corundum, for use in all rotary and impact drills, for surface working on wood, metal and plastic, for edge smoothing, deburring, contouring, particularly suitable for edges and round objects. Also available in face grinding pattern.

Page 198



Polishing wheels

★★★★★

Felt, for use with arbor on standard mains and cordless drills, for applying polishes and waxes on wood, metal, plastics, marble, glass, acrylic and car paintwork. With and without QUICK-STICK hook-and-loop fixing system.

Page 199



Polishing bonnets

★★★★★

Sheepskin, lambswool or felt, for use with arbor on popular mains and cordless drills, for polishing wood, metal, plastics, marble, glass, acrylic and car paintwork. With and without QUICK-STICK hook-and-loop fixing system.

Page 200 - 201

kwb-Info

QUICK-STICK hook-and-loop fixing system

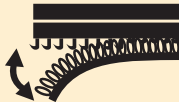

The hook-and-loop backing you can see on the backing pad is self-adhesive. The fabric back of the abrasive disc allows quick, tool free changeovers

QUICK-STICK is available as:

- Sanding discs
- Detail sander sheets
- Scouring pads
- Orbital sander sheets
- Polishing discs
- Polishing bonnets

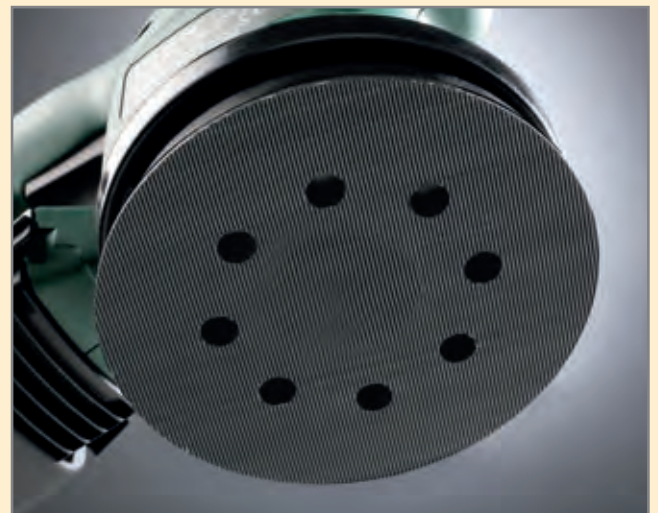













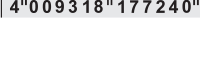

Abrasive rolls, wood and metal, aluminium oxide



Abrasive rolls, for wood and metal, aluminium oxide abrasive coated, 5m long, widths 93 and 115mm, suitable for all leading orbital sanders, also for hand sanding, for sanding metal and wood, paint, varnish, filler, stone and plastics.

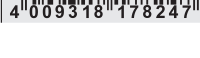

Art.-No.	Width	Grit	Length			Barcode
Wood and metal, aluminium oxide, 93mm						
817704	93 mm	40	5 m		1	
817706	93 mm	60	5 m		1	
817708	93 mm	80	5 m		1	
817712	93 mm	120	5 m		1	
817718	93 mm	180	5 m		1	
817724	93 mm	240	5 m		1	

Art.-No.	Width	Grit	Length			Barcode
Wood & Metal, aluminium oxide, 115mm						
817804	115 mm	40	5 m		1	
817806	115 mm	60	5 m		1	
817808	115 mm	80	5 m		1	
817812	115 mm	120	5 m		1	
817818	115 mm	180	5 m		1	
817824	115 mm	240	5 m		1	

kwb-Info

A safer job











Particularly when working with electric sanders, such as belt sanders and orbital sanders, dust and fine particles will be produced. Protect your airways against this, often invisible, threat. That's why kwb has put together a comprehensive range of dust masks, with or without breather valve.

For all standard applications in the prescribed breathing protection categories.



Finishing sandpaper sheets Wood & Varnish







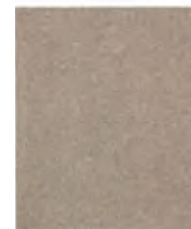





Art.-No.	Contents	Grit			Barcode
bulk					
840040	50	40		Z50	
840060	50	60		Z50	
840080	50	80		Z50	
840100	50	100		Z50	
840120	50	120		Z50	
840150	50	150		Z50	
840180	50	180		Z50	
840240	50	240		Z50	
840320	50	320		Z50	

Sanding sheets 230 x 280mm, wood and paint, aluminium oxide abrasive coated, reinforced paper, flexible, especially suitable for resin paint, acrylic paint, varnish, filler and paint, for wood and metal.



Wet-and-dry sandpaper for Paint & Car



Art.-No.	Contents	Grit			Barcode
bulk					
830080	50	80		Z50	
830120	50	120		Z50	
830180	50	180		Z50	
830240	50	240		Z50	
830320	50	320		Z50	
830400	50	400		Z50	
830600	50	600		Z50	
830800	50	800		Z50	
830980	50	1000		Z50	

Sandpaper sheets 230 x 280mm, wet-and-dry, especially flexible, high stock removal, long life, silicon carbide coated, especially fine grits for car refinishing and working with resin, varnish, paint, glass, stone, plastics and metal.

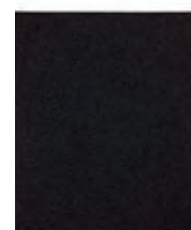

Wet-and-dry sandpaper for Paint & Car, bargain pack



Art.-No.	Format	Contents			Barcode
830960	5 x 180, 5 x 240, 5 x 400, 5 x 600	20		1	

Sandpaper sheets 230 x 280mm, wet-and-dry, especially flexible, high stock removal, long life, silicon carbide coated, especially fine grits for car refinishing and working with resin, varnish, paint, glass, stone, plastic+C73cs and metal.













Blue emery cloth for Metal & Steel



Emery cloth sanding sheets 230 x 280mm for metal and steel, aluminium oxide coated, blue cloth backing, high quality woven reinforcement, flexible, tear-resistant and low-friction, for metal and steel, for removing rust, scale, paint, varnish and resin.











Art.-No.	Contents	Grit			Barcode
bulk					
820040	25	40		Z25	
820060	25	60		Z25	
820080	25	80		Z25	
820100	25	100		Z25	
820120	25	120		Z25	
820150	25	150		Z25	
820180	25	180		Z25	
820240	25	240		Z25	

Aluminium oxide sandpaper Wood & Metal



Sandpaper sheets 230 x 280mm, for wood and metal, aluminium oxide coated, for removing rust, paint, varnish and filler







Art.-No.	Grit			Barcode
bulk				
810040	40		Z50	
810060	60		Z50	
810080	80		Z50	
810100	100		Z50	
810120	120		Z50	
810150	150		Z50	
810180	180		Z50	

Paper sanding discs for wood and metal, aluminium oxide, bargain pack



Sandpaper sheets 230 x 280mm, for wood and metal, aluminium oxide coated, for removing rust, paint, varnish and filler













Art.-No.	Format	Contents			Barcode
810960	5 x 60, 5 x 80, 5 x 150, 5 x 180	20			

Sanding and polishing

Flint sandpaper Wood & Paint



Art.-No.	Grit			Barcode
bulk				
800040	40		Z50	
800060	60		Z50	
800080	80		Z50	
800100	100		Z50	
800120	120		Z50	
800150	150		Z50	
800180	180		Z50	
800240	240		Z50	

Sandpaper sheets 230 x 280mm, wood and paint, flint, for smoothing wood, paint and filler.



Flint sandpaper Wood & Paint, bargain pack



Art.-No.	Format	Contents			Barcode
800960	10 x 40, 20 x 100, 10 x 150, 10 x 180	50		1	

Sandpaper sheets 230 x 280mm, wood and paint, flint, for smoothing wood, paint and filler.



kwb-Info

For flat surfaces and edges.

Rough edges and splinters are easily removed with the kwb cork hand sanding block. This natural product is the classic hand sanding block, suitable for all types of sandpaper. Especially for sanding small areas.

You can find more hand sanders on pages 196 - 197 of our catalogue.



... always the appropriate accessories for your machine!

QUICK-STICK sanding discs, punched, round



Manufacturer / machine model	Ø 115 mm		Ø 125 mm		Ø 150 mm	
	Part.-No.	Catalogue page	Part.-No.	Catalogue page	Part.-No.	Catalogue page
	4918- 5418-	164	4919- 5419- 4959-	164 - 165	4920- 5420- 4960-	165 - 166

AEG						
EX 400, EX 450, EXE 400			x			
EXE 460 (125)			x			
EXE 460, ROS 150 E					x	
ALPHA TOOLS						
ES 125 E			x			
ATLAS - COPCO						
TEX 150			x			
BLACK & DECKER						
BD 190 / S / E / D, KA 198 GT			x			
KA 190 / S / EKA 191 EK,			x			
KA 280, 280 K, XTA 90EK			x			
BOSCH						
PEX 11 A / AE, PEX 115	x					
GEX 125 A / AC, GEX 125-1AE			x			
PEX 12 A/AE, PEX 125 A,			x			
PEX 125 AE, PEX 270 A / AE,			x			
PEX 220A, PEX 300 AE, 400 AE,			x			
GEX 150 AC / ACE, Turbo,					x	
PEX 15 AE, PEX 420 AE					x	
DEWALT						
DW 423, D26453			x			
DW 443, D26410					x	
EINHELL						
EX 115	x					
BT-RS 420 E, RT-XS 28,			x			
BES 125			x			
ELU						
ES 55 E			x			
ES 56 E / EK					x	
ERGOTOOLS						
E-ES 430 E			x			
FEIN						
MSF 636-1			x			
FELISATTI						
TP 521 / E / AS / EAS,					x	
TP 522 AS / CE					x	
FERM						
ESM 1007			x			
FESTO						
ES 125 / E			x			
FLEX						
XS 712 A			x			
X/XS 1107 VE					x	
HILTI						
WFE 380, WFE 450 E					x	
HITACHI						
TSV 13 Y, SV 13 YA / YB			x			
SAY 150 A					x	
KRESS						
CPS 6115-1 / E	x					
CPS 6125-1 / E, HEX 1385 E			x			
HEX 6385 E / Set, 900 MPS			x			
900 HEX					x	

Sanding discs

QUICK-STICK sanding discs, punched, round



Manufacturer / machine model	Ø 115 mm		Ø 125 mm		Ø 150 mm	
	Part.-No.	Catalogue page	Part.-No.	Catalogue page	Part.-No.	Catalogue page
		4918- 5418-	164	4919- 5419- 4959-	164 - 165	4920- 5420- 4960-
MAC ALLISTER						
MOS 450C				x		
MAFELL						
UT 150E						x
MAKITA						
BO 6040, 6030 (8 Löcher)						x
BO 5000, 5010, 5021, 5021 K				x		
METABO						
SXE 125, SXE 425, XL				x		
SXE 425 TURBOTEC				x		
FSX 200 INTEC, SXE 325 INTEC				x		
SXE 450 DUO, TURBOTEC						x
SXE 425 XL						x
MILWAUKEE						
PRS 125 E				x		
ROS 150 E						x
PEUGEOT						
PAE 115		x				
PRX 150 E						x
RYOBI						
ERO 2412VN, CRO 180M				x		
SKIL						
7415		x				
7400, 7402, 7425, 7430, 7435				x		
7440AA, 7460AA				x		
STAYER						
LRT 115		x				
LRT 150, RO 150						x
WEGOMA						
LRE 84 H				x		
RX 91 C, RT 118 N, RTE (1)46L						x
WORX DIY						
WX656, WX652				x		
WORX PRO						
WU651, WU652				x		x
WU654						

Paper sanding discs for wood and metal, aluminium oxide, Ø 125 mm, bargain pack



Paper sanding discs Ø 125 mm, for wood and metal, aluminium oxide abrasive coated, with star centre hole, for use with rubber backing pad kwb part no. 483500 on standard drills and cordless drills, for wood and metal, for derusting, paint, varnish and filler.

Art.-No.	Ø mm	Contents	Grit	☒	📦	Barcode
491150	125	40	12 x 50, 16 x 80, 12 x 120		1	 4 009314 911503

Paper sanding discs for wood and metal, aluminium oxide, Ø 125 mm



Paper sanding discs Ø 125 mm, for wood and metal, aluminium oxide abrasive coated, with star centre hole, for use with rubber backing pad kwb part no. 483500 on standard drills and cordless drills, for wood and metal, for derusting, paint, varnish and filler.

Art.-No.	Ø mm	Contents	Grit	☒	📦	Barcode
490210	125	4	120	☒	12	 4 009314 902105
490220	125	4	80	☒	12	 4 009314 902204
490230	125	4	50	☒	12	 4 009314 902303
491200	125	4	6 x 50, 8 x 80, 6 x 120	☒	12	 4 009314 912005

Backing pad, rubber



Rubber backing pad with arbor, for use with sanding discs with star hole on all standard mains and cordless drills.

Art.-No.	Ø mm	⌀ mm	☒	📦	Barcode
483500	125	8	☒	6	 4 009314 835007

QUICK-STICK sanding discs for wood and metal, aluminium oxide, Ø 115 mm



Sanding discs, Ø 115 mm, for wood and metal, aluminium oxide coated, resin bonded, strong backing material, with hook-and-loop fabric backing, for use with random orbit sanders, for sanding metal and wood, paint, varnish, filler, stone and plastics.











Art.-No.	Ø mm	Contents	Grit	☒	📦	Barcode
487310	115	10	120	☒	6	 4 009314 873108
487320	115	10	80	☒	6	 4 009314 873207
487330	115	10	40	☒	6	 4 009314 873306
487300	115	10	3 x 40, 4 x 80, 3 x 120	☒	6	 4 009314 873009

Sanding discs

QUICK-STICK sanding discs for wood and metal, aluminium oxide, Ø 125 mm



Sanding discs, Ø 125 mm, for wood and metal, aluminium oxide coated, resin bonded, strong backing material, with hook-and-loop fabric backing, for use with random orbit sanders, for sanding metal and wood, paint, varnish, filler, stone and plastics.











Art.-No.	Ø mm	Contents	Grit			Barcode
488310	125	5	120		6	
488320	125	5	80		6	
488330	125	5	40		6	
488300	125	6	2 x 40, 2 x 80, 2 x 120		6	



QUICK-STICK hook and loop Backing Pad



Backing pad, hook and loop type, for sanding discs with fabric hook-and-loop backing, for quick tool-free changing of sanding discs.





Art.-No.	Ø mm	Thread	 mm			Barcode
487000	115		8		6	
487014	115	M14			6	
488000	125		8		6	
488014	125	M14			6	



QUICK-STICK ball-joint backing pad set

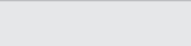

Ball joint backing pad set, with 4 assorted sanding discs, lockable ball joint, optimal ability to align the sanding disc with the surface to be worked, enables low vibration sanding even on large surfaces, with hook-and-loop fixing, for paper sanding discs with hook-and-loop fabric backing, for quick changing of discs with no tool needed.

Art.-No.	Ø mm	for	Contents	 mm			Barcode
482400	125	For sanding discs 488300, -310, -320, -330	Includes 2 each sanding discs 125mm, 80 + 120 grit	8		1	



... always the appropriate accessories for your machine!

QUICK-STICK sanding discs for wood and metal, aluminium oxide, Ø 115 mm, punched



Abrasive sanding discs Ø 115 mm, for wood and metal, aluminium oxide abrasive coated, phenolic resin bonded, strong backing, with hook-and-loop fabric backing, punched, for use with random orbit sanders, for sanding metal and wood, paint, varnish, filler, stone and plastics.



Art.-No.	Ø mm	Contents	Grit			Barcode
display box						
491804	115	5	40		6	4 0093 14 918045
491806	115	5	60		6	4 0093 14 918069
491808	115	5	80		6	4 0093 14 918083
491812	115	5	120		6	4 0093 14 918120
491818	115	5	180		6	4 0093 14 918182
491824	115	5	240		6	4 0093 14 918243
491800	115	5	2 x 40, 2 x 120, 1 x 240		6	4 0093 14 918006

Art.-No.	Ø mm	Contents	Grit			Barcode
bargain pack						
491870	115	25	9 x 60, 8 x 120, 8 x 180		1	4 0093 14 918700

Art.-No.	Ø mm	Contents	Grit			Barcode
trade pack, shrinkwrapped						
541804	115	20	40		1	4 0093 15 418049
541806	115	20	60		1	4 0093 15 418063
541808	115	20	80		1	4 0093 15 418087
541812	115	20	120		1	4 0093 15 418124

QUICK-STICK sanding discs for wood and metal, aluminium oxide, Ø 125 mm, punched



Abrasive sanding discs Ø 125 mm, for wood and metal, aluminium oxide abrasive coated, phenolic resin bonded, strong backing, with hook-and-loop fabric backing, punched, for use with random orbit sanders, for sanding metal and wood, paint, varnish, filler, stone and plastics.





Art.-No.	Ø mm	Contents	Grit			Barcode
display box						
491904	125	5	40		6	4 0093 14 919042
491906	125	5	60		6	4 0093 14 919066
491908	125	5	80		6	4 0093 14 919080
491912	125	5	120		6	4 0093 14 919127
491918	125	5	180		6	4 0093 14 919189
491924	125	5	240		6	4 0093 14 919240
491932	125	5	320		6	4 0093 14 919325
491900	125	5	2 x 40, 2 x 120, 1 x 240		6	4 0093 14 919004







Sanding discs

QUICK-STICK sanding discs for wood and metal, aluminium oxide, Ø 125 mm, punched



Art.-No.	Ø mm	Contents	Grit			Barcode
bargain pack, shrinkwrapped						
491970	125	25	9 x 60, 8 x 120, 8 x 180		1	



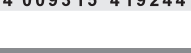









Art.-No.	Ø mm	Contents	Grit			Barcode
trade pack, shrinkwrapped						
541904	125	20	40		1	
541906	125	20	60		1	
541908	125	20	80		1	
541912	125	20	120		1	
541918	125	20	180		1	
541924	125	20	240		1	



QUICK-STICK sanding discs for wood and paint, silicon carbide, Ø 125 mm, punched

















Art.-No.	Ø mm	Contents	Grit			Barcode
display box						
495904	125	5	40		6	
495906	125	5	60		6	
495908	125	5	80		6	
495912	125	5	120		6	

Sanding discs, Ø 125 mm, wood and paint, Silversand, aluminium oxide abrasive coated, Stearate coated to reduce clogging, phenolic resin bonded, reinforced backing, with fabric backing, punched, for use on random orbit sanders, for sanding hard- and softwoods, resin paint, acrylic paint, paints, plastics.



QUICK-STICK sanding discs for wood and metal, aluminium oxide, Ø 150 mm, punched



Art.-No.	Ø mm	Contents	Grit			Barcode
display box						
492004	150	5	40		6	
492006	150	5	60		6	
492008	150	5	80		6	
492012	150	5	120		6	
492018	150	5	180		6	
492024	150	5	240		6	

Abrasive sanding discs Ø 150 mm, for wood and metal, aluminium oxide abrasive coated, phenolic resin bonded, strong backing, with hook-and-loop fabric backing, punched, for use with random orbit sanders, for sanding metal and wood, paint, varnish, filler, stone and plastics.



... always the appropriate accessories for your machine!

QUICK-STICK sanding discs for wood and metal, aluminium oxide, Ø 125 mm, punched



Art.-No.	Ø mm	Contents	Grit			Barcode
bargain pack, shrinkwrapped						
492070	150	25	9 x 60, 8 x 120, 8 x 180		1	4 009314 920703



Art.-No.	Ø mm	Contents	Grit			Barcode
trade pack, shrinkwrapped						
542004	150	20	40		1	4 009315 420042
542006	150	20	60		1	4 009315 420066
542008	150	20	80		1	4 009315 420080
542012	150	20	120		1	4 009315 420127

QUICK-STICK sanding discs for wood and paint, silicon carbide, Ø 150 mm, punched











Sanding discs, Ø 150 mm, wood and metal, silversand, aluminium oxide coated with stearate surface coating which reduces the tendency to clog, resin bonded, strong backing material, with hook-and-loop fabric backing, for use with random orbit sanders, for sanding hard- and soft-woods, resins, acrylic, paint, plastics.



Art.-No.	Ø mm	Contents	Grit			Barcode
Display carton						
496004	150	5	40			4 009314 960044
496006	150	5	60			4 009314 960068
496008	150	5	80			4 009314 960082
496012	150	5	120			4 009314 960129

QUICK-STICK hook and loop Backing Pad, punched, for Bosch random orbit sander





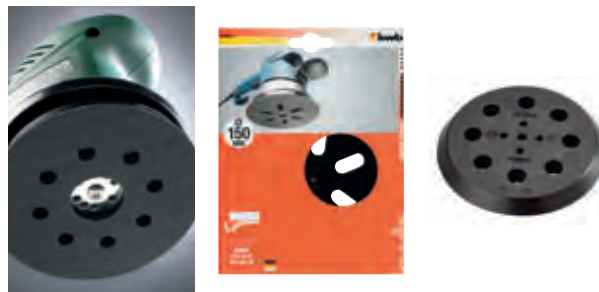

Art.-No.	Ø mm	for			Barcode
480820	115	Bosch PEX 11 A/AE, PEX 115 A/AE, PEX 9.6VA		2	 4 009314 808209
480830	115	Bosch PEX 11 A/AE, PEX 115 A/AE, PEX 9.6VA		2	 4 009314 808308
480920	125	Bosch PEX 11 A/AE, PEX 115 A/AE, PEX 9.6VA		2	 4 009314 809206

Backing pad, hook and loop type, punched, for random orbit sanders, for sanding discs with fabric hook-and-loop backing, for quick tool-free changing of sanding discs.



QUICK-STICK hook and loop Backing Pad, punched, for Bosch random orbit sander



Art.-No.	Ø mm	for			Barcode
481820	125	Bosch PEX 270 A/AE		2	 4 009314 818208

Backing pad, hook and loop type, punched, for random orbit sanders, for sanding discs with fabric hook-and-loop backing, for quick tool-free changing of sanding discs.



... always the appropriate accessories for your machine!

QUICK-STICK triangular and specially shaped sanding discs

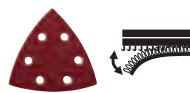

Manufacturer / machine model	96 mm		93 / 100 x 62 mm		93 / 100 x 62 mm (Scouring pads)		105 mm	
	Part.-No.	Catalogue page	Part.-No.	Catalogue page	Part.-No.	Catalogue page	Part.-No.	Catalogue page
	4928- 5428- 4925- 4929-	170 - 171	4961- 4968-	171 - 172	4962-	172	4927-	172

AEG								
DSE 220, DSE 260								x
ALPHA TOOLS								
DS 180	x							
BOSCH								
GDA 280 E, PDA 100,	x							
PDA 120 E, PDA 240 E,	x							
PDA 180, PDA 180 E	x							
PMF 180 E	x							
PSM 160 A, PRIO, VENTARO			x		x			
PSM 80 A			x		x			
BLACK & DECKER								
KA 511 EKA	x							
CASALS								
BLD 180, VLD 230	x							
DEWALT								
D 26430	x							
EINHELL								
BT-DS 180	x							
BDS 180	x							
RT-OS 13			x					
ERGOTOOLS								
E-DS 260	x							
FERM								
DSM 1009, OTM 1001	x							
OTM 1003	x							
HITACHI								
SV 12 SH	x							
KRESS								
CPS 6115-1 / E								x
CPS 6125-1 / E, HEX 1385 E								x
MAKITA								
BO 4561	x							
METABO								
DSE 130, DSE 170,	x							
DSE300 INTEC, DSE280 INTEC	x							
MAC ALLISTER								
MDS 180	x							
SKIL								
Octo 7208			x					
7207AA, 7208AA, 7250AA			x					
7110AA, 7115AA	x							
WORX DIY								
WX55DS	x							

Detail sanding discs

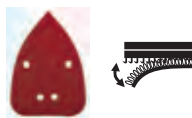
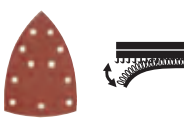
QUICK-STICK Steam iron shape						
	107 x 175 mm punched		97 x 135 mm punched		100 x 147 mm punched	
Manufacturer / machine model	Part.-No.	Catalogue page	Part.-No.	Catalogue page	Part.-No.	Catalogue page
	4934-	173	4936-	173	4930-	174
BOSCH						
PSM 160 A, PRIO, VENTARO					x	
PSM 80 A					x	
BLACK & DECKER						
KA 220 Multi, Multi E,	x					
KA 225, KA 250 K, KA 270	x					
KA 1000-Mouse			x			
KA 280, 280 K	x					
EINHELL						
RT-XS 28	x					
FERM						
PSM 1013, PSM 1012	x					
METABO						
FMS 200 INTEC					x	
MAC ALLISTER						
MDS 100			x			
WORX DIY						
WX646	x					

... always the appropriate accessories for your machine!

QUICK-STICK sanding discs for wood and metal, aluminium oxide, 96mm



Delta sanding discs, 96mm, for wood and metal, aluminium oxide abrasive coated, phenolic resin bonded, strong backing, with hook-and-loop fabric backing, punched, for use with delta/ detail sanders, for sanding metal and wood, paint, varnish, filler, stone and plastics.



Art.-No.	Ø mm	Contents	Grit			Barcode
display box						
492804	96	5	40		6	
492806	96	5	60		6	
492808	96	5	80		6	
492812	96	5	120		6	
492818	96	5	180		6	
492824	96	5	240		6	
492832	96	5	320		6	
492840	96	5	400		6	
492800	96	5	2 x 40, 1 x 120, 2 x 240		6	



Art.-No.	Contents	Grit			Barcode
bargain pack, shrinkwrapped					
492870	20	8 x 60, 6 x 120, 6 x 180		1	



Art.-No.	Ø mm	Contents	Grit			Barcode
Trade bargain pack, shrinkwrapped						
542834	96	20	40		6	
542836	96	20	60		6	
542838	96	20	80		6	
542842	96	20	120		6	
542848	96	20	180		6	

QUICK-STICK triangular sanding discs for wood and paint, silicon carbide, 96mm



Delta sanding discs, Ø 96 mm, wood and paint, Silversand, aluminium oxide abrasive coated, Stearate coated to reduce clogging, phenolic resin bonded, reinforced backing, with fabric backing, punched, for use on delta sanders, for sanding hard- and softwoods, resin paint, acrylic paint, paints, plastics.









Art.-No.	Ø mm	Contents	Grit			Barcode
display box						
492504	96	5	40		6	
492506	96	5	60		6	
492508	96	5	80		6	
492512	96	5	120		6	

Detail sander sheets

QUICK-STICK scouring pad, 96mm















Art.-No.	∅ mm	Contents	Grit			Barcode
display box						
492912	96	1	120		5	
492928	93	1	280		5	

Scouring pad, 96mm, hook-and-loop fixing, with aluminium oxide abrasive, phenolic resin bonded, with hook-and-loop fabric backing, for use with delta sanders, for matt-finishing of metal and varnish, smoothing of wood fibres and de-rusting metal.





QUICK-STICK sanding discs for wood and metal, aluminium oxide, 100 x 62, 93mm



Art.-No.	Contents	Grit			Barcode
display box					
496104	5	40		6	
496106	5	60		6	
496108	5	80		6	
496112	5	120		6	
496118	5	180		6	

Detail sanding discs, 100 x 62, 93mm, for wood and metal, aluminium oxide abrasive coated, phenolic resin bonded, strong backing, with hook-and-loop fabric backing, punched, for use with detail sanders, for sanding metal and wood, paint, varnish, filler, stone and plastics.



Art.-No.	Contents	Grit			Barcode
bargain pack, shrinkwrapped					
496170	4	5 x 60, 5 x 120, 5 x 180		1	















... always the appropriate accessories for your machine!

QUICK-STICK triangular sanding discs for wood and paint, silicon carbide, 100 x 62, 93mm



Detail sanding discs, Silversand, 93mm, for wood and paint, aluminium oxide abrasive with stearate surface coating to reduce clogging, phenolic resin bonded, strong backing, with hook-and-loop fabric backing, punched, for use with delta/ detail sanders, for sanding hard- and soft-wood, lacquer, acrylic paint, paint, plastics.







Art.-No.	Contents	Grit			Barcode
display box					
496804	5	40		6	
496806	5	60		6	
496808	5	80		6	
496812	5	120		6	
496818	5	180		6	

QUICK-STICK scouring pad 100 x 62, 93mm



Scouring pad, 100 x 62, 93mm, hook-and-loop fixing, with aluminium oxide abrasive, phenolic resin bonded, with hook-and-loop fabric backing, for use with detail sanders, for matt-finishing of metal and varnish, smoothing of wood fibres and de-rusting metal.













Art.-No.	Contents	Grit			Barcode
display box					
496228	1	280		1	





QUICK-STICK triangular sanding discs for wood and metal, aluminium oxide, 105mm



Delta sanding discs, 105mm, for wood and metal, aluminium oxide abrasive coated, phenolic resin bonded, strong backing, with hook-and-loop fabric backing, punched, for use with delta/ detail sanders, for sanding metal and wood, paint, varnish, filler, stone and plastics.



















Art.-No.	∅ mm	Contents	Grit			Barcode
display box						
492704	105	5	40		6	
492706	105	5	60		6	
492708	105	5	80		6	
492712	105	5	120		6	



Art.-No.	∅ mm	Contents	Grit			Barcode
bargain pack, shrinkwrapped						
492770	105	20	8 x 60, 6 x 120, 6 x 180		1	

Detail sander sheets

QUICK-STICK sanding sheets for wood and metal, aluminium oxide, 107 x 175mm



Art.-No.	Contents	Grit			Barcode
display sleeve					
493404	5	40		6	
493406	5	60		6	
493408	5	80		6	
493412	5	120		6	
493418	5	180		6	
493424	5	240		6	
493400	5	2 x 40, 2 x 120, 1 x 240		6	













Art.-No.	Contents	Grit			Barcode
bargain pack, shrinkwrapped					
493470	4	5 x 60, 5 x 120, 5 x 180		1	



Triangular sanding discs for wood and metal, aluminium oxide coated, 107 x 175mm, resin bonded, strong backing material, with hook and loop backing, punched, for delta/triangular sanders, for sanding metal and wood, paint, varnish, filler, stone and plastics



QUICK-STICK sanding discs for wood and metal, aluminium oxide, 96 x 136mm



Art.-No.	Contents	Grit			Barcode
display sleeve					
493608	5	80		6	
493612	5	120		6	
493618	5	180		6	
493624	5	240		6	
493600	5	2 x 80, 1 x 120, 2 x 240		6	

Art.-No.	Contents	Grit			Barcode
bargain pack, shrinkwrapped					
493670	4	6 x 80, 5 x 120, 4 x 240		1	

Sanding discs for wood and metal, 96 x 136mm, aluminium oxide abrasive coated, phenolic resin bonded, strong backing, with hook-and-loop fabric backing, punched, for detail sanders, for sanding metal and wood, paint, varnish, filler, stone and plastics.



... always the appropriate accessories for your machine!

QUICK-STICK sanding discs for wood and metal, aluminium oxide, 100 x 147mm



Sanding discs for wood and metal, 100 x 147mm, aluminium oxide abrasive coated, phenolic resin bonded, strong backing, with hook-and-loop fabric backing, punched, for detail sanders, for sanding metal and wood, paint, varnish, filler, stone and plastics.

Art.-No.	Contents	Grit			Barcode
bargain pack, shrinkwrapped					
493070	4	5 x 60, 5 x 120, 5 x 180		6	4 009314 930702



QUICK-STICK hook and loop Backing Pad, punched, for Delta sanders



For Bosch Delta detail sanders PDA 100, PDA 120 E. Backing pad, punched, for delta sander, with hook and loop fixing, for sanding discs with hook and loop fabric backing, for quick, tool-free disc changing.

Art.-No.	Dimensions			Barcode
493100	93 x 93 x 93 mm		1	4 009314 931006



QUICK-STICK hook and loop Backing Pad, punched, for Delta sanders





For Bosch Delta detail sanders PDA 180, PDA 240, GDA 280. Backing pad, punched, for delta sander, with hook and loop fixing, for sanding discs with hook and loop fabric backing, for quick, tool-free disc changing.

Art.-No.	Dimensions			Barcode
495100	93 x 93 x 93 mm		1	4 009314 951004







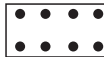
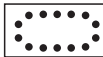













... always the appropriate accessories for your machine!

Orbital sander sheets STANDARD										
Size: Width x length	93 x 230 mm		115 x 280 mm		punched type A 93 x 230 mm	punched type B 93 x 230 mm	punched 115 x 280 mm			
Manufacturer / machine model	Part.-No.	Page	Part.-No.	Page	Part.-No.	Page	Part.-No.	Page	Part.-No.	Page
	815-	180	812-	180	8181-	181	8182-	181	8187-	182
UNIVERSAL										
With clamps without dust extraction	x		x							
AEG										
VS 130, VSE 130, VS 230	x				x					
VSS 260 / E	x				x					
VS 14, VS 20, VSE 20, VSS 20									x	
VSSE 20, VS 250, VSE 250									x	
VSS 280, VSSE 280									x	
ALPHA TOOLS										
ASS 280									x	
ATLAS COPCO										
VS 230, VSE 230,			x				x			
VSS 260, VSSE 260			x				x			
VS 280 E, VS 280 SE									x	
VSE 230, VSS 20 E									x	
BLACK & DECKER										
DN 41 A, DN 41 AE, BD 175,	x				x					
BD 180, BD 180 E, KA 300	x				x					
KA 185, KA 185 E	x				x					
BD 175, BD 180 E, DN 41 AE,			x				x			
DN 180 E, KA 186 E, KA 196,			x				x			
KC 185 E, KC 273, KC 962,			x				x			
CD 400, VB 135 B			x				x			
SR 400, PL 52										
BD 273, DN 49, DN 273,									x	
DN 41 AE, DN 180 E, KC 962,									x	
P 63-03, P 63-04, P 63-05,									x	
KA 180 E, KA 274 EKA,									x	
SR 410 E, VB 135 A, VB 250 E									x	
KA 273									x	
KA 310, KA 320 EKA	x				x					
BOSCH										
GSS 23 AE, GSS 230 A/ AE			x				x			
PSS 23 A/AE, PSS 240 A/AE			x				x			
GSS 23 AE, PSS 230			x				x			
GSS 9,6 V, GSS 140 A										
GSS 28 A/AE, GSS 280 A/AE,									x	
PSS 28 AE, PSS 280 AE									x	
PSS 300 AE									x	
GSS 28 A									x	
CASALS										
BLR 170, YLR 210			x				x			
BLR 250									x	
LN 216, LR 228									x	
DEWALT										
DW 411, D26411										
D26420, D26421									x	
D26422, D26423			x				x			
EINHELL										
EST 170			x				x			
RT-OS 30									x	
BT-OS 280 E									x	
BT-RS 420 E, RT-XS 28										
ELU										
MVS 47, MVS 91, MVS 94									x	
VS 280, VSE/VSSE 280									x	
VS 41, VS 71									x	





Orbital sander sheets STANDARD

Orbital sander sheets STANDARD										
Size: Width x length	93 x 230 mm		115 x 280 mm		punched type A 93 x 230 mm	punched type B 93 x 230 mm	punched 115 x 280 mm			
Manufacturer / machine model	Part.-No.	Page	Part.-No.	Page	Part.-No.	Page	Part.-No.	Page	Part.-No.	Page
	815-	180	812-	180	8181-	181	8182-	181	8187-	182
ERGOTOOLS										
E-VS 280										x
FEIN										
MSS 641 a, MSS 641 b										x
FESTO										
RS 3 SFE, RS 3E SFE										
LRB-IAS, LRB-T1, RS 1, RS 2,										x
RS 2 E, RTB, RTB-E, RTB-EA,										x
RTR-S2, RTT-S2, RTS, 2 RB-IAS										x
HILTI										
WFO 280										x
HITACHI										
SV 12 SD, SV 12 V										x
KRESS										
CRS 6175 E, CRS 6175 ES										x
CRS 6165 A, 300 RSE										x
MAKITA										
9036		x						x		
BO 3711, BO 3700		x						x		
BO 4553, BO 4554, BO 4555										
BO 4556, BO 4558										
BO 9046, BO 4901, BO 4900 V										x
METABO										
SR 356, SR 4350				x				x		
SR 226, SRE 227, SR 10-23				x				x		
SR 20-23				x				x		
SR 180 INTEC, SRE 357				x				x		
SR 328, 4321, SRE 329, 359										x
PEUGEOT										
DN 180, DN 180 E, KA 185 A,		x						x		
KA 185 E, KC 962, VB 135 A		x						x		
10 TV I AS		x						x		
PV 240 A, TV 4102				x				x		
BP 22 E										x
RYOBI										
NS 401, NS 801, S 35				x				x		
S 605 D, EOS 2410										
ESS 1890C, ESS 2590V				x				x		
ESS 3215V										x
SKIL										
7310, 7315, 7350, 7385,				x				x		
7300, 7320, 7330, 7340, 7360,				x				x		
7365, 7390, 7395				x				x		
7351AA, 7366AA				x				x		
7576 U, 7312AA										
7380AA, 7300										x
666										x
WORX PRO										
WU645										
WU644, WU641								x		

... always the appropriate accessories for your machine!

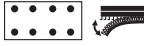
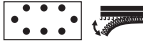
Orbital sander sheets QUICK-STICK	 	 	 	 	 									
Size: Width x length	punched 80 x 133 mm		punched 93 x 185 mm		punched 93 x 187 mm		punched 100 x 115 mm		punched 115 x 230 mm		Mesh sanding sheets 93 x 230 mm		Mesh sanding sheets 115 x 280 mm	
Manufacturer / machine	Part.-No.	Page	Part.-No.	Page	Part.-No.	Page	Part.-No.	Page	Part.-No.	Page	Part.-No.	Page	Part.-No.	Page
	8184-	182	8183-	183	8179-	183	8180-	184	8189-	184	851-	185	854-	185
UNIVERSAL														
With clamps without dust extraction											x		x	
AEG														
VS / E 230, VS / E 260			x											
FS 2	x													
ATLAS COPCO														
VS 230, VSE 230, VSS 260, VSSE 260			x											
VS 11	x													
VSS 22			x											
VS 280 E, VS 280 SE, VSE 230, VSS 20 E									x					
BLACK & DECKER														
P 63-01	x													
KA 175, KA 186, KA 186 E			x		x									
KA 273									x					
KA 310, KA 320 EKA					x									
BOSCH														
GSS 23 AE, GSS 230 A/ AE, PSS 23 A/AE, PSS 240 A/AE			x											
PSS 180 A, PSS 200 A, PSS 250 AE			x											
GSS 28 A/AE, GSS 280 A/AE, PSS 28 AE, PSS 280 AE									x					
PSS 300 AE									x					
PSS 289 AE									x					
GSS 16 A	x													
CASALS														
KLAR 210			x											
BLR 250									x					
VLR 300									x					
DEWALT														
D26420, D26421											x			
D26422, D26423			x											
EINHELL														
EST 170			x											
LRS 93 G/M, RS 3/E			x											
ERU 270									x					
RT-OS 30									x					
ELU														
VS 41, VS 71									x					
FELISATTI														
TP 31 E	x													
FERM														
PSM 1024			x											
FESTO														
RS 4, RS 4 E, RS 4 STF/ESTF	x													
RS 400 (-Plus)	x													
RS 3 E, RS 3 SFE			x											
RS 1 STF, RS 2 STF, RS 2 E									x					
FESTOOL														
RTS 400	x													
RS 200									x					
RS 300, LRS 93			x											

Orbital sander sheets QUICK-STICK

Orbital sander sheets QUICK-STICK														
	Size: Width x length	punched 80 x 133 mm	punched 93 x 185 mm	punched 93 x 187 mm	punched 100 x 115 mm	punched 115 x 230 mm	Mesh sanding sheets 93 x 230 mm	Mesh sanding sheets 115 x 280 mm	Part.-No.	Page	Part.-No.	Page	Part.-No.	Page
Manufacturer / machine	8184-	182	8183-	183	8179-	183	8180-	184	8189-	184	851-	185	854-	185
HITACHI														
SV 8 SA	x													
FS 10 SB			x											
SV 12 SF, 12 SG, 12 SH							x							
SV 12 SD, SV 12 V									x					
HOLZ HER														
2241									x					
KRESS														
CRS 6165 A, 300 RSE									x					
CRS 6175 EA									x					
MAC ALLISTER														
MSS 260					x									
MSS 300									x					
MAFELL														
UK 115 / U 115E									x					
MAKITA														
9036			x											
BO 4556, BO 4554, BO 4561							x							
BO 4554, BO 4561							x							
9045 B, 9045 N									x					
BO 9046, BO 4901, BO 4900 V									x					
METABO														
SR 356, SR 4350			x											
SR 357			x											
SR 10-23 INTEC, SR 20-23			x											
FSR 200 INTEC							x							
SR 358, SRE 4351									x					
MILWAUKEE														
POS 13	x													
PEUGEOT														
PV 240 A, TV 4102			x											
TV 4003, TV 4103									x					
RYOBI														
ESS 1890C, ESS 2590V			x											
S 33 K			x											
NS 6200, NS 6300 A									x					
ESS 3215V									x					
SKIL														
7300, 7320, 7330, 7340, 7360			x											
7365, 7390, 7395			x											
7351AA, 7366AA			x											
7270, 7300 S			x											
666									x					
WEGOMA														
LR 184 H			x											
WORX DIY														
WX637								x						
WX639, WX640, WX26FS					x									
WORX PRO														
WU644, WU641			x											
WEGOMA														
LR 184 H			x											

... always the appropriate accessories for your machine!

Sanding sheets Wood & Metal, aluminium oxide, 93 x 230mm



Sanding sheets for wood and metal, 93 x 230mm, aluminium oxide abrasive coated, for wood and metal, for derusting, paint, varnish and filler. For orbital sanders.



Art.-No.	Contents	Grit			Barcode
Display carton					
815040	10	40		5	
815080	10	80		10	
815120	10	120		10	
815180	10	180		10	
815240	10	240		10	

Art.-No.	Contents	Grit			Barcode
bargain pack, shrinkwrapped					
815888	50	12 x 60, 12 x 80, 13 x 120, 13 x 180		1	

Sanding sheets Wood & Metal, aluminium oxide, 115 x 280mm



Sanding sheets for wood and metal, 115 x 280mm, aluminium oxide abrasive coated, for wood and metal, for derusting, paint, varnish and filler. For orbital sanders.













Art.-No.	Contents	Grit			Barcode
Display carton					
812040	10	40		5	
812080	10	80		10	
812120	10	120		10	
812240	10	240		10	

Art.-No.	Contents	Grit			Barcode
bargain pack, shrinkwrapped					
812999	50	12 x 60, 12 x 80, 13 x 120, 13 x 180		1	

Orbital sander sheets



Sanding sheets Wood & Metal, aluminium oxide, 93 x 230mm, punched, Type A



Art.-No.	Contents	Grit			Barcode
Display carton					
818104	10	40		10	
818108	10	80		10	
818112	10	120		10	
818124	10	240		10	

Sanding sheets for wood and metal, 93 x 230mm, universal punching, aluminium oxide abrasive coated for wood and metal, for derusting, paint, varnish, and filler. For orbital sanders with dust extraction.













Art.-No.	Contents	Grit			Barcode
bargain pack					
818188	30	7 x 40, 7 x 80, 8 x 120, 8 x 180		1	





Sanding sheets Wood & Metal, aluminium oxide, 93 x 230mm, punched, Type B



Art.-No.	Contents	Grit			Barcode
Display carton					
818204	10	40		10	
818208	10	80		10	
818212	10	120		10	
818224	10	240		10	

Sanding sheets for wood and metal, 93 x 230mm, universal punching, aluminium oxide abrasive coated for wood and metal, for derusting, paint, varnish, and filler. For orbital sanders with dust extraction.



Art.-No.	Contents	Grit			Barcode
bargain pack					
818288	30	7 x 40, 7 x 80, 8 x 120, 8 x 180		1	













... always the appropriate accessories for your machine!



Sanding sheets Wood & Metal, aluminium oxide, 115 x 280mm, punched



Sanding sheets for wood and metal, 115 x 280mm, universal punching, aluminium oxide abrasive coated for wood and metal, for derusting, paint, varnish, and filler. For orbital sanders with dust extraction.



Art.-No.	Contents	Grit			Barcode
Display carton					
818704	10	40		5	
818708	10	80		5	
818712	10	120		5	
818724	10	240		5	











Art.-No.	Contents	Grit			Barcode
bargain pack					
818788	30	7 x 40, 7 x 80, 8 x 120, 8 x 180		1	

QUICK-STICK sanding sheets for wood and metal, aluminium oxide, 80 x 133mm



Sanding sheets for wood and metal, 80 x 133mm, aluminium oxide abrasive coated, phenolic resin bonded, strong backing, with hook-and-loop fabric backing, punched. For orbital sanders with hook-and-loop bases and dust extraction, for sanding metal and wood, paint, varnish, filler, stone and plastics.















Art.-No.	Contents	Grit			Barcode
Display carton					
818404	5	40		5	
818408	5	80		5	
818412	5	120		5	
818418	5	180		5	

Orbital sander sheets





QUICK-STICK sanding sheets for wood and metal, aluminium oxide, 93 x 185mm



Art.-No.	Contents	Grit			Barcode
Display carton					
818304	5	40		5	
818308	5	80		5	
818312	5	120		5	
818318	5	180		5	
818324	5	240		5	

Sanding sheets for wood and metal, 93 x 185mm, aluminium oxide abrasive coated, phenolic resin bonded, strong backing, with hook-and-loop fabric backing, punched. For orbital sanders with hook-and-loop bases and dust extraction, for sanding metal and wood, paint, varnish, filler, stone and plastics.







Art.-No.	Contents	Grit			Barcode
bargain pack, shrinkwrapped					
818388	4	3 x 40, 4 x 60, 4 x 80, 4 x 120		1	



QUICK-STICK sanding sheets for wood and metal, aluminium oxide, 93 x 186mm



Art.-No.	Contents	Grit			Barcode
817980	10	3 x 40, 4 x 80, 3 x 240		5	

Sanding sheets for wood and metal, 93 x 186mm, aluminium oxide abrasive coated, phenolic resin bonded, strong backing, with hook-and-loop fabric backing, punched. For orbital sanders with hook-and-loop bases and dust extraction, for sanding metal and wood, paint, varnish, filler, stone and plastics.















... always the appropriate accessories for your machine!

QUICK-STICK sanding sheets for wood and metal, aluminium oxide, 115 x 100mm



Sanding sheets for wood and metal, 115 x 100mm, aluminium oxide abrasive coated, phenolic resin bonded, strong backing, with hook-and-loop fabric backing, punched. For orbital sanders with hook-and-loop bases and dust extraction, for sanding metal and wood, paint, varnish, filler, stone and plastics.















Art.-No.	Contents	Grit			Barcode
Display carton					
818004	5	40		5	
818008	5	80		5	
818012	5	120		5	
818018	5	180		5	
818024	5	240		5	

QUICK-STICK sanding sheets for wood and metal, aluminium oxide, 115 x 230mm



Sanding sheets for wood and metal, 115 x 230mm, aluminium oxide abrasive coated, phenolic resin bonded, strong backing, with hook-and-loop fabric backing, punched. For orbital sanders with hook-and-loop bases and dust extraction, for sanding metal and wood, paint, varnish, filler, stone and plastics.



Art.-No.	Contents	Grit			Barcode
Display carton					
818904	5	40		5	
818908	5	80		5	
818912	5	120		5	
818918	5	180		5	
818924	5	240		5	

kwb-Info

A safer job

Particularly when working with electric sanders, such as belt sanders and orbital sanders, dust and fine particles will be produced. Protect your airways against this, often invisible, threat. That's why kwb has put together a comprehensive range of dust masks, with or without breather valve.







For all standard applications in the prescribed breathing protection categories.



Orbital sander sheets





Mesh sanding sheets for render and plasterboard, 93 x 230mm



Art.-No.	Contents	Grit			Barcode
Display carton					
851120	2	120		5	
851180	2	180		5	







Mesh abrasive sanding sheets, fibreglass reinforced mesh construction, silicon carbide abrasive, for sanding render, removing paint, resin, acrylic, rust. No clogging of the abrasive



Art.-No.	Contents	Grit			Barcode
bargain pack					
851820	5	120		5	
851880	5	180		5	





Mesh sanding sheets, render and plasterboard, 115 x 280mm



Art.-No.	Contents	Grit			Barcode
Display carton					
854120	2	120		5	
854180	2	180		5	

Mesh abrasive sanding sheets, fibreglass reinforced mesh construction, silicon carbide abrasive, for sanding render, removing paint, resin, acrylic, rust. No clogging of the abrasive



Art.-No.	Contents	Grit			Barcode
bargain pack					
854820	5	120		5	
854880	5	180		5	

... always the appropriate accessories for your machine!

Sanding belts 40 x 303 mm - 75 x 533 mm

Size: Width x length	40 x 303 mm		60 x 400 mm		65 x 410 mm		75 x 457 mm		75 x 480 mm		75 x 510 mm		75 x 533 mm	
	Part.-No.	Page	Part.-No.	Page	Part.-No.	Page	Part.-No.	Page	Part.-No.	Page	Part.-No.	Page	Part.-No.	Page
Manufacturer / machine	9107-	189	9110-	189	9114-	189	9119-	189	9121-	190	9123-	190	9125-	190
							9019-	190					9025-	191
AEG														
HBS 65, HBSE 65						x								
HBSE 75 S, HBSE 600,														x
RBSE 75 AE														x
ALPHA TOOLS														
BBS 720								x						
ATLAS COPCO														
HBSE 75, MBSE 705														x
BLACK & DECKER														
BD 83/E, DN 83/E, KA 83/E						x								
BS 650						x								
KA 85, KA 85 E, KA 86								x						
DN 85 / E, BD 85, P 61-03											x			
SR 500 E, KA 83											x			
BD 75 / E, KA 75 / E, KA 88														x
XT 80Ek														x
BOSCH														
Vario Schl. GVS 350 AE	x													
PBS 60, PBS 60 E				x										
PBS 7 A, PBS 7AE								x						
PBS 75, E, PBS 75 A/ AE														x
0270, GBS 75 A/AE														x
CASALS														
LC 75														x
DEWALT														
DW 430, 431, 432, 433														x
DURO														
DBS 600								x						
EINHELL														
BT-BS 850 E, BBS 720								x						
RT-BS 75														x
ELU														
MHB 157 / E, MHB 158 / E										x				
ERGOTOOLS														
E-BS 800														x
FELISATTI														
TP 411														x
FERM														
BSM 1021, BSM 1022														x
FESTO														
BS 75, BS 75 E/-Plus, BS 75 E-Set														x
HITACHI														
SB 75, SB 8V2														x
HOLZ HER														
2405 Derby, 2406						x								
2288, 2410, 2411, E, 2420, E														x
KRESS														
CBS 6800, E, 600 HTEB						x								
MAC ALLISTER														
MBS 800														x
MAKITA														
9910, 9911								x						
9900 B, 9901, 9902, 9903														x

Sanding belts

Sanding belts 40 x 303 mm - 75 x 533 mm

Size: Width x length	40 x 303 mm		60 x 400 mm		65 x 410 mm		75 x 457 mm		75 x 480 mm		75 x 510 mm		75 x 533 mm	
	Part.-No.	Page	Part.-No.	Page	Part.-No.	Page	Part.-No.	Page	Part.-No.	Page	Part.-No.	Page	Part.-No.	Page
Manufacturer / machine	9107-	189	9110-	189	9114-	189	9119-	189	9121-	190	9123-	190	9125-	190
							9019-	190					9025-	191
METABO														
Ba 0665, Ba E 0666						x								
BAE 0775, BAE 0875, BAE 75														x
BAE 0876 Signal, BaE 1075														x
PARKSIDE														
PBS 900 A1														x
PEUGEOT														
PB 600, PB 75, PB 600/H								x						
TPB 7500								x						
PAB 75														x
RYOBI														
B-7075, B 7076, EBS 8021V														x
B 850F / K7, BE 321SF														x
EBS 9576														x
SKIL														
1100, 1200 / H, 1205 / H								x						
1210AA, 7600 A, 7610, 7620								x						
7630, 7640, 7650, 7675 S								x						
594 U, 599 U, 7640, 7650														x
STAYER														
LEN 75														x
TOOLSON														
Pro-BS 850 E														x
TOOLTEC														
700 Watt								x						
WORX DIY														
WX660								x						
WX661														x
WORX PRO														
WU661								x						
WU663														x











... always the appropriate accessories for your machine!

Sanding belts 75 x 610 mm - 105 x 620 mm + 13 x 457 mm

Size: Width x length	75 x 610 mm		100 x 560 mm		100 x 610 mm		105 x 620 mm		13 x 457 mm	
	Part.-No.	Page	Part.-No.	Page	Part.-No.	Page	Part.-No.	Page	Part.-No.	Page
Manufacturer / machine model	9130-	191	9144-	191	9145-	191	9147-	191	9105-	192
AEG										
HBS 100, HBSE 100,			x							
BBS 1100, BBSE 1100			x							
HBS 2-110, HBS 10 / E							x			
ATLAS COPCO										
BBS 100 / E			x							
BBS 100 / E							x			
BLACK & DECKER										
Powerfile BD 280, BD 282 E,									x	
BD 290, BD 292 E, DN 280,									x	
DN 282 E, KA 290, KA 292 E									x	
KA 293 E, KA 900 E									x	
BOSCH										
1270, GBS 100 A/AE							x			
CASALS										
LC 110							x			
DEWALT										
DW 650, 650 E			x							
EINHELL										
BT-BS 1200					x					
ELU										
MHB 90 / E / K			x							
FESTO										
BUZ-S, BU 25			x							
BS 105/E(-Set)							x			
FESTOOL										
BS 105							x			
HITACHI										
9924 DB	x									
SB 10 T, 10 V, 10 S2, 10 V2					x					
SB 110							x			
HOLZ HER										
2422, 2423, E, 2424, E							x			
MAKITA										
9924, 9920	x									
9401 / 02 / 03 / 04, 9924 DB					x					
9402, 9924 DB							x			
MAFELL										
ZUB 110							x			
METABO										
Ba 6100							x			
RYOBI										
B-7100	x									
HB-422, HABE-422, B 422,			x							
BE 422 K 5			x							
B-7200 A, EBS 1310VF, BE 424					x					
SKIL										
1400 H, 1405 H										
WEGOMA										
LB 31 EA					x					

Sanding belts, wood and metal, aluminium oxide















Art.-No.	Contents	Grit			Barcode
40 x 303 mm					
910704	3	40		3	
910706	3	60		3	
910708	3	80		3	
910715	3	150		3	

Sanding belts, aluminium oxide coated, resin bonded, body made from strong, elastic woven cotton, special glueing, chatter and flutter-free working.















Sanding belts, wood and metal, aluminium oxide

















Art.-No.	Contents	Grit			Barcode
60 x 400 mm					
911004	3	40		3	
911006	3	60		3	
911008	3	80		3	
911010	3	100		3	
911015	3	150		3	

Sanding belts, aluminium oxide abrasive coated, phenolic resin bonded, heavy, super-elastic cloth backing, special glueing, chatter- and flutter-free joint.



Art.-No.	Contents	Grit			Barcode
65 x 410 mm					
911404	3	40		3	
911406	3	60		3	
911408	3	80		3	
911410	3	100		3	
911415	3	150		3	









Art.-No.	Contents	Grit			Barcode
75 x 457 mm					
911904	3	40		3	
911906	3	60		3	
911908	3	80		3	
911910	3	100		3	
911912	3	120		3	
911915	3	150		3	







... always the appropriate accessories for your machine!

Sanding belts, wood and metal, aluminium oxide

















Art.-No.	Contents	Grit			Barcode
bargain pack, shrinkwrapped					
901904	10	40		1	 4 009319 019044
901906	10	60		1	 4 009319 019068
901908	10	80		1	 4 009319 019082
901910	10	100		1	 4 009319 019105



















Art.-No.	Contents	Grit			Barcode
75 x 480 mm					
912115	3	150		3	 4 009319 121150



Art.-No.	Contents	Grit			Barcode
75 x 510 (508) mm					
912304	3	40		3	 4 009319 123048
912306	3	60		3	 4 009319 123062
912308	3	80		3	 4 009319 123086
912310	3	100		3	 4 009319 123109
912312	3	120		3	 4 009319 123123
912315	3	150		3	 4 009319 123154













Art.-No.	Contents	Grit			Barcode
75 x 533 mm					
912502	3	24		3	 4 009319 125028
912504	3	40		3	 4 009319 125042
912506	3	60		3	 4 009319 125066
912508	3	80		3	 4 009319 125080
912510	3	100		3	 4 009319 125103
912512	3	120		3	 4 009319 125127
912515	3	150		3	 4 009319 125158



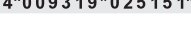









Sanding belts













Sanding belts, wood and metal, aluminium oxide

















Art.-No.	Contents	Grit			Barcode
bargain pack, shrinkwrapped					
902502	5	24		1	
902504	10	40		1	
902506	10	60		1	
902508	10	80		1	
902510	10	100		1	
902515	10	150		1	

Art.-No.	Contents	Grit			Barcode
75 x 610 mm					
913015	3	150		3	

Art.-No.	Contents	Grit			Barcode
100 x 560 mm					
914404	3	40		3	
914406	3	60		3	
914408	3	80		3	
914410	3	100		3	
914415	3	150		3	

Art.-No.	Contents	Grit			Barcode
100 x 610 mm					
914504	3	40		3	
914506	3	60		3	
914508	3	80		3	
914510	3	100		3	
914515	3	150		3	

Art.-No.	Contents	Grit			Barcode
105 x 620 mm					
914704	3	40		3	
914706	3	60		3	
914708	3	80		3	
914710	3	100		3	
914712	3	120		3	
914715	3	150		3	



... always the appropriate accessories for your machine!

Sanding belts, wood & metal, aluminium oxide, 13 x 457mm



Sanding belts, aluminium oxide coated, resin bonded, body made from strong, elastic woven cotton, special glueing, chatter and flutter-free working.



Art.-No.	Contents	Grit			Barcode
13 x 457 mm					
910504	3	40		3	4 009319 105044
910506	3	60		3	4 009319 105068
910508	3	80		3	4 009319 105082
910510	3	100		3	4 009319 105105

kwb-Info

A safer job



Our eyes, as one of the most important sensory organs, must always be protected while working.











That's why kwb has put together for all common situations when drilling, shaping, grinding or welding indoors or outdoors, a high quality protective eyewear range also suitable for spectacle-wearers.

You can find further information in our kwb **Personal Protection catalogue** or on the Internet at www.kwb.eu.



Sanding Sponge for wood and metal







Art.-No.	Contents	Grit			Barcode
display sleeve					
089010	3	Fine		6	
089020	3	Medium		6	
089030	3	Coarse		6	
089000	3	1 x fine, 1 x medium, 1 x coarse		6	

Sanding sponge, silicon carbide abrasive coated 2 sides, 125 x 100 x 10mm, body highly flexible polyurethane foam, phenolic resin bonded, wet-and-dry use. Sanding waste can be washed off. Long working life, specially suitable for sanding shaped surfaces. For derusting, paint. For cleaning and surface preparation when repainting with resin or acrylic paints.







Sanding Sponge UNI-SCHLEIFIX for wood and metal



Art.-No.	Grit			Barcode
bulk in counter display carton				
089120	Fine, medium		20	
089130	Medium, coarse		20	

Sanding sponge, aluminium oxide abrasive coated 4 sides, one small side and one large side with like abrasive grade, 2 different grits, body highly flexible polyurethane foam, phenolic resin bonded, wet-and-dry use. Sanding waste can be washed off. Long working life, especially suitable for sanding shaped surfaces. For derusting, paint. For cleaning and surface preparation when repainting with resin or acrylic paints. Good for surface preparation when repainting door and window frames.



Art.-No.	Grit			Barcode
bulk				
089111	Fine		50	
089121	Fine, medium		50	
089131	Medium, coarse		50	



Sanding Sponge AUTO-SCHLEIFIX, for paint and car, waterproof



Sanding sponge, coated 4 sides, 100 x 70 x 26mm, silicon carbide, one narrow and one broad side in the same grit, 2 different grits, body made from highly flexible polyurethane foam, resin bonded, wet-and-dry use. Sanding waste can be washed off. Long life, especially good for sanding shaped surfaces. For removing rust, paint. For automotive and bike use.



Art.-No.	Grit			Barcode
bulk in counter display carton				
089210	Fine		20	
089220	Fine, medium		20	
089230	Medium, coarse		20	

Art.-No.	Grit			Barcode
bulk				
089211	Fine		50	
089221	Fine, medium		50	
089231	Medium, coarse		50	

Polycarbide cleaning wheel



Polycarbide cleaning discs, coarse, for sanding with the edge or the face of the disc, flexible, nylon filaments bonded to silicon carbide abrasive, for cleaning and derusting on sheet steel, non-ferrous metals, plastics, stone and wood, for use with drills, good for working exactly up to an edge.

Art.-No.	Ø mm	mm			Barcode
479100	100	8		6	

Polycarbide cleaning wheels, 20-piece assortment



Polycarbide cleaning discs, 20-piece assortment in counter display, coarse, for sanding with the edge or the face of the disc, flexible, nylon filaments bonded to silicon carbide abrasive, for cleaning and derusting on sheet steel, non-ferrous metals, plastics, stone and wood, for use with drills.

Art.-No.	Ø mm	Length			Barcode
479192	100	8		Z18	

Steel wool

Steel wool, small rolls



Art.-No.	Contents	Grit	Number			Barcode
089700	6 small rolls	Fine	00		6	

Steel wool, varietal quality steel, highly tear resistant, elastic. For polishing, matt-finishing, fine sanding and cleaning of metal and wood.



Steel wool, pads



Art.-No.	Contents	Grit	Number			Barcode
089400	2 pads	Fine	00		6	
089410	2 pads	Medium	01		6	
089430	2 pads	Coarse	03		6	

Steel wool, varietal quality steel, highly tear resistant, elastic. For polishing, matt-finishing, fine sanding and cleaning of metal and wood.



Steel wool



Art.-No.	Contents	Grit	Number			Barcode
089500	200 g	Fine	00		1	
089510	200 g	Medium	01		1	
089530	200 g	Coarse	03		1	
089560	200 g	Extra fine	000		1	

Steel wool, varietal quality steel, highly tear resistant, elastic. For polishing, matt-finishing, fine sanding and cleaning of metal and wood.



Steel wool, stainless steel



Art.-No.	Contents	Grit	Number			Barcode
089600	150 g	Extra fine	000		1	
089610	150 g	Medium	01		1	

Steel wool, rust resistant quality steel, highly tear resistant, flexible. Ideal for all outdoor jobs, no rust particles left on the finished surface.

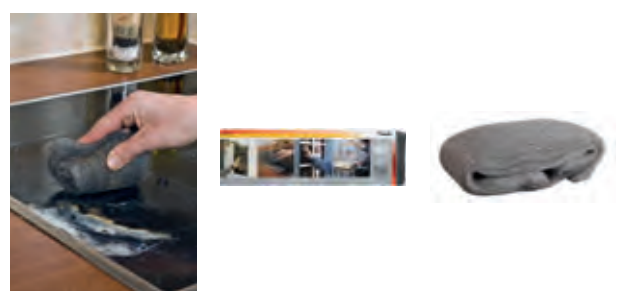

Profi hand sander, with spring clamps



Hand sander for use with 93 x 230mm sanding sheets. With spring clamps, ergonomically designed grip for fatigue-free working, 4mm thick sponge rubber working surface underneath.



Art.-No.	Dimensions			Barcode
bulk				
485121	165 x 87 mm		10	4 009314 851212

PROFI hand sander set, with 50 sanding sheets 93 x 230mm



Hand sander to take sanding sheets 93 x 230mm. With spring clamps, 50 sanding sheets included, aluminium oxide abrasive coated, for wood and metal, for derusting, paint, varnish and filler. Also can be used on orbital sanders.



Art.-No.	Contents	Grit			Barcode
485170	1 Hand sander 4851, sanding sheets 93 x 230mm	12 x 60, 12 x 80, 13 x 120, 13 x 180		1	4 009314 851700

Flexible hand sanding block, rubber



Rubber hand sanding pad, ideal for all hand sanding jobs, lies perfectly in the hand due to its rounded shape, with its sharply pointed ends allows sanding into recesses and close to edges, with inbuilt securing pins to keep the sandpaper firmly anchored.









Art.-No.	Dimensions			Barcode
carded				
485000	130 x 70 mm		6	4 009314 850000

Hand sanders

Hand Sanding Block, cork

★★★★★





Art.-No.	Dimensions			Barcode
carded				
484800	40 x 60 x 100 mm		12	
484900	40 x 80 x 120 mm		12	

Cork hand sanding block, a natural product, the classic hand sanding tool, suitable for all types of sandpaper when sanding small areas.



Hand sander set with 2 mesh sanding sheets

★★★



Art.-No.	Contents			Barcode
484200	Hand sander, mesh sanding sheets 1 x 120, 1 x 180		1	

Hand sander with spring clamps for all sanding sheets size 93 x 230mm. Mesh sanding sheets, fibreglass reinforced mesh, resin bonded with silicon carbide abrasive, for smoothing filler, removing paint, resin, acrylic lacquer, rust without clogging.



Hand Sander Set, bargain pack, with 12 mesh sanding sheets

★★★★★

Art.-No.	Contents			Barcode
484250	Hand sander, mesh sanding sheets 1 x 120, 1 x 180, value pack 10 x 120		1	

Hand sander with spring clamps for all sanding sheets size 93 x 230mm. Mesh sanding sheets, fibreglass reinforced mesh, resin bonded with silicon carbide abrasive, for smoothing filler, removing paint, resin, acrylic lacquer, rust without clogging.



Fleece flap wheel



Fleece flap wheel, combi-wheel, with sandpaper and abrasive fleece, aluminium oxide, for especially fine sanding on metal, wood and plastics, particularly good for flat and curved surfaces.

Art.-No.	Grit	Head Ø x height	mm			Barcode
088310	150- fine	50 x 25	6		2	4 009310 883101
088330	60- coarse	50 x 25	6		2	4 009310 883309
088410	150- fine	75 x 45	6		2	4 009310 884108
088430	60- coarse	75 x 45	6		2	4 009310 884306

Flap wheels, aluminium oxide, face grinding



Abrasive flap wheels, aluminium oxide, suitable for sanding with the face or the side, for wood, metal and plastic, especially suitable for flat and curved surfaces.

Art.-No.	Grit	Head Ø x height	mm			Barcode
088010	120- fine	60 x 40	6		6	4 009310 880100
088030	60- coarse	60 x 40	6		6	4 009310 880308

Flap wheels, aluminium oxide



Abrasive flap wheels, aluminium oxide, for wood, metal and plastic, especially suitable for flat and curved surfaces.

Art.-No.	Grit	Head Ø x height	mm			Barcode
088110	120- fine	50 x 20	6		6	4 009310 881107
088130	60- coarse	50 x 20	6		6	4 009310 881305

Polishing media

QUICK-STICK polishing sponge, hook and loop



Polishing sponge, Moltopren, with fabric backing to fit backing pads with hook-and-loop fastening, for applying polishes and waxes to wood, metal, plastics, marble, glass, acrylic and car bodywork.

Art.-No.	∅ mm	for backing pads			Barcode
486600	125	115 - 125 mm		1	



QUICK-STICK Felt polishing wheel, hook and loop



Felt polishing wheel, with hook-and-loop fabric backing, for use with hook-and-loop backing pads, for applying polishes and waxes to wood, metal, plastics, marble, glass, acrylic and car paintwork.

Art.-No.	∅ mm	for backing pads			Barcode
486000	125	115 - 125 mm		6	



QUICK-STICK Felt polishing pad, hook and loop, for Delta sanders



Felt polishing wheel, with hook-and-loop fabric backing, for use with hook-and-loop backing pads, for applying polishes and waxes to wood, metal, plastics, marble, glass, acrylic and car paintwork.

Art.-No.	∅ mm	for backing pads			Barcode
493000	96	96 mm		5	



Felt polishing wheel



Felt polishing wheel, for use with arbor on standard electric and cordless drills, for the application of polishes and waxes to wood, metal, plastics, marble, glass, acrylic and car re-finishing

Art.-No.	∅ mm	∅ inside			Barcode
511300	75	13 mm		6	



Buffing Wheels



Nettlecloth buffing wheel, for use with arbor on standard cordless and mains drills, for polishing wood, metal, plastics, marble, glass, acrylic and car bodywork.

Art.-No.	Ø mm	Ø inside			Barcode
517300	75	13 mm		6	4 009315 173009
517400	100	13 mm		6	4 009315 174006

Polishing bonnet

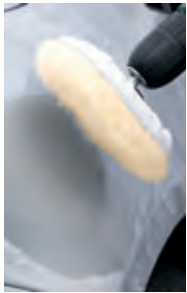

Polishing bonnet, genuine lambswool, with tie to fit standard backing pads, for polishing wood, metal, plastics, marble, glass, acrylic and car bodywork.

Art.-No.	Ø mm	for backing pads			Barcode
485500	135	4835		10	4 009314 855005

Polishing bonnet



Polishing bonnet, woven lambswool, with drawstring to fasten to standard backing pads, for polishing wood, metal, plastics, marble, glass, acrylic and car paintwork.

Art.-No.	Ø mm	for backing pads			Barcode
484500	135	4835		10	4 009314 845006

QUICK-STICK polishing bonnet, hook and loop



Polishing bonnet, genuine lambswool, with fabric backing, for use with backing pads with hook-and-loop fixing, for polishing wood, metal, plastics, marble, glass, acrylic and car bodywork.

Art.-No.	Ø mm	for backing pads			Barcode
484600	125	115 - 125 mm		6	4 009314 846003

QUICK-STICK polishing bonnet, hook and loop



Polishing bonnet, woven lambswool, with fabric backing for use with hook and loop backing pads, for polishing wood, metal, plastics, marble, glass, acrylic and car paintwork.

Art.-No.	Ø mm	for backing pads			Barcode
484700	135	115 - 125 mm		6	4 009314 847000

Polishing media

Polishing set SPECIAL, 5-piece



Polishing set Special, 5-piece, for high gloss polishing, for use on wood, metal, plastics, marble, glass, acrylic and car paintwork, for use in commonly used drills and cordless drills.





Art.-No.	Contents			Barcode
485200	1 Polishing compound, white 1 High gloss polishing compound, blue 1 Felt wheel 1 Cloth wheel 1 Arbor		3	



Polishing Set STANDARD, 6-piece



Standard polishing set, 6-piece, for polishing wood, meetal, plastics, marble, glass, acrylic and car refinishing, for use with standard mains and cordless drills

Art.-No.	Contents			Barcode
485300	1 First Polish compound, brown 1 First Polish compound, white 1 Sisal wheel 2 Cloth wheels 1 Arbor		3	



Polishing Compound Set, 2-piece



Polishing compound set, 2-piece, first polishing compound and polishing compound







Art.-No.	Contents			Barcode
485420	1 Polishing compound, white 1 High gloss polishing compound, blue		5	



Universal Arbor



Arbor, left hand thread, with two clamping washers and clamp nut, for clamping ceramic grinding wheels, felt polishing wheels, buffing wheels, sisal brushes and polishing wheels for standard mains and cordless drills.

Art.-No.	Ø Flange	Ø mm	mm			Barcode
501000	34	10	6		6	
501200	34	1/2" / 12,75	8		6	

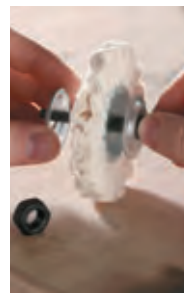

... always the appropriate accessories for your machine!





ROUTER CUTTER TUNGSTEN CARBIDE PLANER BLADES

Router Cutters



Benefits of router cutters

- Router cutters with 8mm shank for a range of grooving and profiling jobs in hard- and softwoods
- for use with all popular hand-held routers
- ideal for all standard applications in workshop, DIY and building site

Programme overview router cutters, tungsten carbide planer blades

Router cutters are only for use in all standard hand-held routers and for safety reasons must not be used in drills.

IMPORTANT:

Because of extremely high rotation speed it is essential to wear hand and eye protection.



Flute cutters

★★★★★

Made from HSS steel, with two cutters, precision ground, for use in all popular hand-held routers. Precision milling of grooves in fibrous hard- and softwoods as well as plastics.

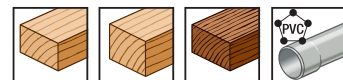

Page 206

kwb-Info



Bearing guide - what is it?

A bearing guide on the top of a router cutter provides an optimal and exact milling guide. Blemish-free and clean finished surfaces are guaranteed.

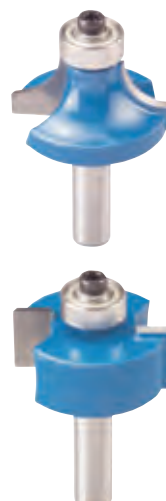

Tungsten carbide tipped cutters with bearing guide

★★★★★

Tungsten carbide tipped flute and profile cutters for long working life in woodworking, with two cutters and bearing guide.

Precision ground, for use with all popular hand-held routers.

Precision milling of grooves, rebates and profiles in hard- and softwoods, chipboard and composite boards.

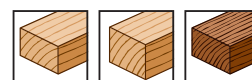

Page 207 - 210

Tungsten carbide planer blades



Tungsten carbide planer blades

- Tungsten carbide planer blades for all popular electric planers for woodworking

Always the right planer blade

Because of the large number of different electric planers it's not so easy to find the right blades. The kwb machine reference guide is arranged by manufacturer and gives a quick and simple overview. You can find the reference chart on page 211 of the catalogue.



Tungsten carbide cutters ★★★★★

Tungsten carbide tipped groove and profile cutters for long working life in woodworking, with two cutters. Precision ground, for use in all popular hand-held routers. Precision milling of grooves, rebates and profiles in hard- and softwoods, chipboard, composite boards.

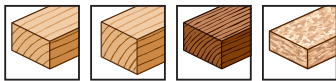

Page 207 - 210



Tungsten carbide plane blades ★★★★★

Special tungsten carbide planer blades with 2 cutting edges. Precision ground, for use in popular electric planers, for planing hard- and softwoods.

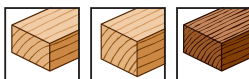

Page 211

kwb-Info



A safer job

It's always a good idea to wear protective gloves when your hands could possibly be injured, for example in building work with sharp-edged objects etc. For all types of work, a safe grip and wearer comfort are the prime requirements for the correct type of glove.



You can find all the relevant information in our **Personal Protection catalogue**, or on the Internet at www.kwb.eu.

Flute cutter HSS



Flute cutter, HSS steel, 2 cutters, precision ground cutting edges, for milling grooves, edges and slots, for hard- and softwoods as well as plastics, for all standard hand-held routers.

Art.-No.	Ø mm	ℓ mm			Barcode
750410	4	8		1	
750510	5	8		1	
750610	6	8		1	
750810	8	8		1	
751010	10	8		1	

Flute cutter TCT



Flute cutter, HSS steel, 2 cutters, precision ground cutting edges, for milling grooves, edges and slots, for hard- and softwoods as well as boards and plastics, for all standard hand-held routers.

Art.-No.	Ø mm	ℓ mm			Barcode
754620	6	8		1	
754820	8	8		1	
754420	10	8		1	
754520	12	8		1	
754720	14	8		1	
754320	18	8		1	
754920	16	8		1	
755020	20	8		1	

Core box router bit TCT



Core box bit, tungsten carbide tipped, 2 cutters, precision ground cutting edges, for making half round grooves, decorative mouldings, surfacing and as insert in conjunction with a copying jig, for hard- and softwoods as well as boards and plastics, for all standard hand-held routers.

Art.-No.	Ø mm	Radius R	ℓ mm			Barcode
755820	12,7	R = 9,4	8		1	
754120	19,0	R = 12,0	8		1	

Router cutters

Core box router bit TCT, with bearing guide



Core box bit, tungsten carbide tipped, 2 cutters, with bearing guide, precision ground cutting edges, for making half round grooves, for hard- and softwoods as well as boards and plastics, for all standard hand-held routers.

Art.-No.	Ø mm	Radius R	mm	mm	mm	Barcode
755920	25,7	6,35	8	8	1	4 009317 559207

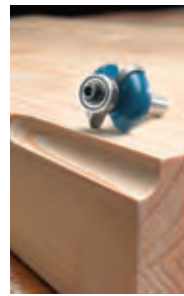

Vee Groove router Bit TCT



Vee-grooving bit, tungsten carbide tipped, 2 cutters, precision ground cutting edges, for making a V-shaped groove for mouldings or surface decoration, or as insert in a copying jig, for hard- and softwoods as well as boards and plastics, for all standard hand-held routers.

Art.-No.	Ø mm	Angle	mm	mm	mm	Barcode
755120	14	W = 90°	8	8	1	4 009317 551201



Dovetail router bit TCT, with scribe



Dovetail bit, tungsten carbide tipped, 2 cutters, precision ground cutting edges, for making dovetail joints in cabinet-making, for hard- and softwoods as well as boards and plastics, for all standard hand-held routers.

Art.-No.	Ø mm	Angle	mm	mm	mm	Barcode
756020	14	W = 14°	8	8	1	4 009317 560203



Rebating cutter TCT, with bearing guide



Rebating bit, tungsten carbide tipped, 2 cutters, precision ground cutting edges, for rebating in solid wood in furniture and frame making, eg windows, doors and pictures, for hard- and softwoods as well as boards, for all standard hand-held routers.

Art.-No.	Ø mm	mm	mm	mm	Barcode
756220	31,7	8	8	1	4 009317 562207



Rounding over bit TCT, with bearing guide



Rounding-over bit, tungsten carbide tipped, 2 cutters, precision ground cutting edges, for rounding the edges of shelves, worktops, cupboards, windows, for hard- and softwoods as well as boards, for all standard hand-held routers.

Art.-No.	Ø mm	Radius R	⌘ mm			Barcode
756620	25,7	R = 6,35	8		1	4 009317 566205
756420	32	R = 9,52	8		1	4 009317 564201

Ovolo bit TCT, with bearing guide



1/4 Ovolo bit, tungsten carbide tipped, 2 cutters, precision ground cutting edges, to make a quarter-circle profile, for hard- and softwoods, for all standard hand-held routers.

Art.-No.	Ø mm	Radius R	⌘ mm			Barcode
756320	25,4	R = 6,35	8		1	4 009317 563204
756120	31,7	R = 9,52	8		1	4 009317 561200

Chamfering bit TCT, with bearing guide



Chamfering bit, tungsten carbide tipped, 2 cutters, precision ground cutting edges, for chamfering the edges of straight or curved workpieces, for hard- and softwoods as well as boards and plastics, for all standard hand-held routers.

Art.-No.	Ø mm	Angle	⌘ mm			Barcode
756520	35,5	W = 45°	8		1	4 009317 565208

Bevel and trim cutter TCT



Bevel and trim bit, tungsten carbide tipped, 2 cutters, precision ground cutting edges, for making a bevelled edge on straight or curved workpieces, for hard- and softwoods as well as boards and plastics, for all standard hand-held routers.

Art.-No.	Ø mm	Angle	⌘ mm			Barcode
755220	11,7	W = 22°	8		1	4 009317 552208



Router cutters

T-slot cutter TCT (hanging slot cutter)



T-grooving bit, tungsten carbide tipped, 2 cutters, precision ground cutting edges, for making a T-shaped groove (keyhole slot) for vertical hanging, or for captive hex head bolts, or for concealing electric cables, for hard- and softwoods as well as boards and plastics, for all standard hand-held routers.







Art.-No.	∅ mm	T mm			Barcode
755520	5 / 9,5	8		1	

Flush trim router bit TCT, with bearing guide



Flush trim bit, tungsten carbide tipped, 2 cutters, precision ground cutting edges, for flush trimming or milling of the openings for switches, sockets, spotlights in installation, shop-fitting, exhibitions, for hard- and softwoods as well as boards and plastics, for all standard hand-held routers.







Art.-No.	∅ mm	T mm			Barcode
755420	13	8		1	

Engraving router bit TCT



Engraving bit, tungsten carbide tipped, 2 cutters, precision ground cutting edges, for lettering or engraving in solid wood and boards, also as insert in conjunction with a copying jig, for hard- and softwoods as well as boards and plastics, for all standard hand-held routers.







Art.-No.	∅ mm	T mm			Barcode
755720	8	8		1	

Beading router bit TCT, with bearing guide

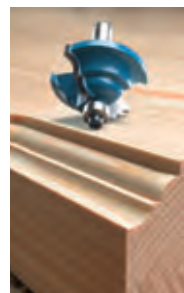

Beading bit, tungsten carbide tipped, 2 cutters, precision ground cutting edges, for making half round grooves, for making a decorative moulded edge on furniture, door frames, cornices, picture frames, for hard- and softwoods as well as boards and plastics, for all standard hand-held routers.



Art.-No.	∅ mm	Radius R	T mm			Barcode
756720	39,2	R = 4,79 / 6,35	8		1	

Beading router bit TCT



Beading bit, tungsten carbide tipped, 2 cutters, precision ground cutting edges, for making half round grooves, for making a decorative moulded edge on furniture, door frames, cornices, picture frames, for hard- and softwoods as well as boards and plastics, for all standard hand-held routers.

Art.-No.	Ø mm	Radius R	ℓ mm			Barcode
756820	12,7	R = 3,2	8		1	4 0093 17 5682 01

Beading router bit TCT, with bearing guide

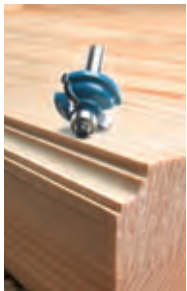

Beading bit, tungsten carbide tipped, 2 cutters, precision ground cutting edges, for making half round grooves, for making a decorative moulded edge on furniture, door frames, cornices, picture frames, for hard- and softwoods as well as boards and plastics, for all standard hand-held routers.

Art.-No.	Ø mm	Radius R	ℓ mm			Barcode
756920	28,1	6,35	8		1	4 0093 17 5692 06

Slotting cutter TCT, with arbor



Slotting bit, tungsten carbide tipped, 2 cutters, precision ground cutting edges, for cutting narrow slots in narrow edges eg for tongue and groove joinery, jointing biscuits, or door seals, for hard- and softwoods as well as boards and plastics, for all standard hand-held routers.

Art.-No.	ℓ mm	ℓ mm			Barcode
754020	2,0	8		1	4 0093 17 5402 05
754030	3,0	8		1	4 0093 17 5403 04
754040	4,0	8		1	4 0093 17 5404 03

Tungsten carbide planer blades

Planer blades, tungsten carbide



Tungsten carbide planer blades, with 2 cutting edges, straight, precision ground, special carbide, for planing in cabinet making and interior work, for planing hard- and softwoods, to fit market-leading electric planers



Art.-No.	Width	kwb part no.	Length	↑↓	☐	📦	Barcode
567502	5,5	H 75	75,5	1,1	☐	1	
568102	5,5	H 81	82,7	1,2	☐	1	
568302	5,5	H 83	82	1,1	☐	1	

Manufacturer / machine model	kwb Code	H 75	H 81	H 83
	Part.-No.	5675-	5681-	5683-
AEG				
HTH 75		x		
EH 82/822, EH 450, H 750, EH 823, E 500, EH 82 S, EH 700 (R), EH 82-1				x
BLACK & DECKER				
DN 750, DN 75, SR 600 K, BD 750, KW 750		x		
DN 710/712, P 71-02, PL 806, P 71-03, DN 730			x	
BD 710, BD 711, DN 730, DN 740, KW 735 E, KW 725, KW 713				x
BOSCH				
PHO 150, PHO 200, PHO 300, PHO 100, PHO 2-82, PHO 3-82, GHO 3-82, GHO 31-82, GHO 36-82 C				x
CASALS				
CE 82				x
FEIN				
HS 2151				x
FELISATTI				
TP 282				x
FESTO				
REP 75		x		
HAFFNER				
FH 222		x		
FH 224		x		x
HITACHI				
F 20, F 20 A, FP 20 A, FP 20 SA, FU 20, P 20 SA, P 20 V				x
HOLZ-HER				
2286, 2320, 2321, (2322), 2223 (R 1985)		x		
2330, 2321, 2323, 2223 (1989 R)				x
KRESS				
Jet Star 6701, 6702		x		
EH 6782-3				x
MAFELL				
HU 75		x		
EHU 82, MHU 82/ EH 82 S				x
MAKITA				
1100, 1125 B, 1900 B, 1923 H, 1923 B, 1001, 1901				x
METABO				
6375		x		
HO 4382, HO 0882, HO 8382, Gustav (HO 3360), HO 0883, HO 0983				x
PERLES				
HHB 82 B				x
PEUGEOT				
BRA 3-82, RA 400, 82 RAC, RA 3082 C, RA 1082 CA, BR 82				x
SCHEER				
MH 80, MH 75/3		x		
SKIL				
98 H		x		
92 H, 94 H, 95 H, 96 H, 97 H				x

... always the appropriate accessories for your machine!



LINE MASTER

The patented rail system with over 50 possibilities for accurate working. kwb, perfection for over 80 years.

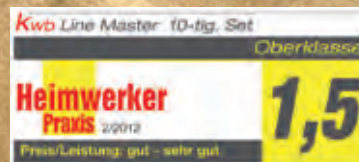

... always the appropriate accessories for your machine!

Trim, mark, saw, cut
and guide with just one
system:

LINE MASTER

The patented precision rule is the core
of the LINE MASTER.

To go with the patented precision rule, there is a
comprehensive programme of add-ons available.



Available in three lengths:

800 mm	Part no. 784208
1000 mm	Part no. 784210
1200 mm	Part no. 784212

LINE MASTER Set



The **angle fence** for setting
angles in 15° steps from 30°
to 150°.



The **blade guide** for clean
and accurate trimming with a
snap-off knife.



The **fixing clamps** to firmly
hold the precision rule.



The **handgrip set with drilling
point markers** is an
indispensable aid for many
wall-mounting jobs, eg hanging
pictures.



The **saw guide** for precision
guiding of jigsaws and circular
saws.

LINE MASTER accessory range



The **rule joiner** is ideal for extra
large workpieces



The **router guide** allows
precise milling of either straight
or rounded profiles.



The **circle cutting guide** for
exact cutting of half-circles
and radius cuts.











With the **adaptor for the
Dubelprofi dowel guide** you
can pre-drill holes accurately
for dowel fixing of wood.

Line Master

LINE MASTER Precision Rule



Made from anodised aluminium, the LINE MASTER precision rule with its guide grooves is at the heart of the LINE MASTER system, with its unlimited wealth of uses. The mm scale is applied using a special resin so is extremely resistant to being erased. The LINE MASTER precision rule meets the standard of accuracy class II of the German Institute of Physics.





Art.-No.	Width	Length				Barcode
784208	58	800	10		2	
784210	58	1000	10		2	
784212	58	1220	10		2	



LINE MASTER angle fence, 15° graduations



The sturdy angle fence fits all LINE MASTER precision rules. Angles can be set from 30 to 150 degrees in 15 degree steps. The retractable fin underneath allows use as an angle guide on the face of the workpiece or as a rip fence against the edge of the workpiece. Glass-fibre reinforced plastic.

Art.-No.	Contents			Barcode
784300	LINE MASTER Fence, glas fibre reinforced plastic, 15° graduations		2	



LINE MASTER fixing clamps



The fixing clamp holds the LINE MASTER precision rules rock-solid to the workpiece, for example when sawing with the LINE MASTER machine guide.



Art.-No.	Contents			Barcode
784500	LINE MASTER Clamp, glass fibre reinforced plastic jaw		2	4 009317 845003



LINE MASTER machine guide



The machine guide is the cleverest part of the LINE MASTER system. Jigsaws and circular saws (max. Ø 190 mm) can be guided so precisely that inaccurate cuts are a thing of the past. The machine guide is made of glassfibre reinforced plastic and fits to any size of LINE MASTER precision rule.



Art.-No.	Contents			Barcode
784400	LINE MASTER Machine Guide, glass fibre reinforced plastic, with measuring scale		2	4 009317 844006



LINE MASTER blade guide



With the blade carrier, you can use snap-off knives, trimming knives and hook knives with all LINE MASTER precision rules for safe and millimetre-accurate trimming.

Art.-No.	Contents			Barcode
784600	LINE MASTER Blade Guide, glass fibre reinforced plastic		2	4 009317 846000



LINE MASTER handle set with drill marking points



This useful handle with built-in spirit level bubble makes every LINE MASTER rule into a spirit level; and makes the LINE MASTER easier to handle. Your extra advantage is that the level can be rotated in 15 degree steps. The pair of trammel points can be positioned on the inch scale of the LINE MASTER and fixed in place with a thumb-screw. An invaluable aid to many wall-mounted fixing jobs!

Art.-No.	Contents			Barcode
784800	1 LINE MASTER Handle2 Drilling Point Markers with steel points		1	4 009317 848004





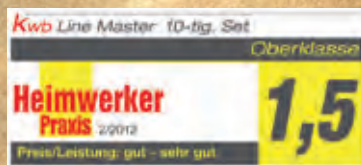









LINE MASTER Universal set



The patented rail system in a 10-piece universal complete set helpful for all DIY-ers

The set consists of either 80 or 120cm precision rule (Part no. 784208 or 784212), angle fence (Part no. 784300), two fixing clamps (Part no. 784500), a machine guide for circular saws and jigsaws (Part no. 784400), a blade guide (Part no. 784600), a Design snap-off knife (Part no. 014000) and a handle set with drilling point markers (Part no. 784800)

Art.-No.	Contents			Barcode
783408	LINE MASTER Universal set		1	
783412	LINE MASTER Universal set		1	
783908	LINE MASTER Universal set		1	





Contents	Art.-No.	Art.-No.	Art.-No.
LINE MASTER SET	783908	783408	783412
Precision rule 800 mm 	Art.-No. 784208 ✓	✓	
Precision rule 1200 mm 	Art.-No. 784212		✓
Angle fence 	Art.-No. 784300 ✓	✓	✓
Fixing clamps 	Art.-No. 784500 ✓	✓	✓
Machine guide for circular saws and jigsaws 	Art.-No. 784400 ✓	✓	✓
Blade guide 	Art.-No. 784600 ✓	✓	✓
Handle set with drilling point markers 	Art.-No. 784800 ✓	✓	✓
Design snap-off knife 	Art.-No. 014000 ✓	✓	✓

LINE MASTER Professional set



Professional starter set of the patented rail system, an invaluable DIY aid. The starter Profiset consists of an 80cm precision rule (Part no. 784208), insertable angle fence (Part no. 784300), two fixing clamps (Part no. 784500), and a machine guide for circular- and jigsaws (Part no. 784400).

Art.-No.	Contents			Barcode
784008	LINE MASTER Professional set		1	





Contents	Art.-No.
LINE MASTER SET	784008
Precision rule 800 mm 	Art.-No. 784208 ✓
Angle fence 	Art.-No. 784300 ✓
Fixing clamps 	Art.-No. 784500 ✓
Machine guide for circular saws and jigsaws 	Art.-No. 784400 ✓

Line Master

LINE MASTER rule connector



A metre often isn't enough. With the rule connector you can join two or more LINE MASTER precision rules firmly and accurately to make one long rule. The connector doesn't obstruct the guide groove so you can make one long saw cut. Plastic profile, glass-fibre reinforced, 4-point fixing.





Art.-No.	Length			Barcode
784900	250		1	 4 009317 849001



LINE MASTER Circle cutting guide for jigsaws, with centre fixing



Circles, semi circles and radii can be sawn with the LINE MASTER rip fence effortlessly and as accurately as though they had been drawn with compasses.

Art.-No.	Contents			Barcode
783600	LINE MASTER Rip Fence for Jigsaws, with centering device		1	 4 009317 836001

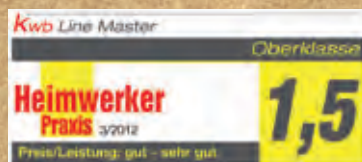





LINE MASTER router guide, with centre fixing



The milling of accurate round profiles becomes so easy with the help of the LINE MASTER Router guide system.
You can also find the centre with or without nailing the pin into the workpiece. For milling straight profiles, the router can of course also be used with the LINE MASTER precision rule.



Art.-No.	Contents			Barcode
783500	LINE MASTER Router Guide, with centering device		1	 4 009317 835004



LINE MASTER Adaptor for kwb Dowel Guide



The kwb DÜBELPROFI Dowel guide (item no. 758000) simplifies the repetitive drilling of dowel holes for the assembly of shelves and cabinet compartments. Fits all LINE MASTER precision rules.



Art.-No.	for			Barcode
784700	758000 / 758100		2	 4 009317 847007

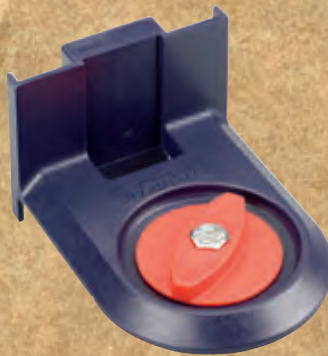



JIGSAW BLADES
**RECIPROCATING
SAW BLADES**
**MULTITOOL
ACCESSORIES**

Jigsaw blades, reciprocating saw blades



For every job, always the right blade

- **Jigsaw blades**
for cutting wood, metal, laminates, plastics, tiles, ceramics, porcelain, rubber
- **Reciprocating saw blades**
for cutting wood, pruning, green wood, firewood, metal, tiles, ceramics, porcelain

Qualities

HCS High carbon steel

Jigsaw blades made from high carbon steel, set, sharpened or cross-ground, for working hard- and softwoods and plastics.

HSS

Fully hardened high speed steel, for use in harder materials, for metal, aluminium, non-ferrous metal etc.

Bi-metal

Highly flexible, almost unbreakable bond of HSS to high carbon steel, also for use in harder materials, extremely supple, for wood, non-ferrous metal, aluminium, also good for abrasive materials.

Tungsten carbide gritted

High carbon steel blade body coated with tungsten carbide grit, specially for use in tiles, ceramics, glass, brick, castings and abrasive materials.

Diamond coated

Diamond coated, ideal for clean, accurate cuts in tiles and ceramics; for hard tiles, porcelain, glass, cast iron, marble.

kwb-Info

Shank overview



T-shaft, also called cruciform fitting

The T-shaft or cruciform fitting has become the standard jigsaw blade shank. This now fits almost all recently manufactured jigsaws.



U-shank, also called Universal shank

The U-shank or Universal shank still fits many popular DIY jigsaws.

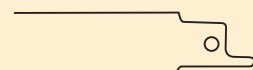

S-Shaft, also called 1/2" sabre saw shank

The S-Shaft or 1/2" sabre saw shank fits most popular electric reciprocating saws and sabre saws.

Multitool accessories



kwb Allrounder for a wealth of uses

- Huge variety of uses, for example sawing, milling, rasping, scraping, sanding
- Comprehensive kwb accessory programme for multitools from all leading manufacturers
- **QUICK-CHANGE** for easy and quick tool changeover

Programme overview multitool accessories



Plunge-cutting saw blades ★★★★★

Simple plunge-cutting into the workpiece in every situation, problem-free insertion cuts in laminate flooring, kitchen worktops, in cupboards or plasterboard, multiple variations for wood or metal, for specially clean and quick cuts choose the plunge-cutting blade with Japanese teeth (see picture).

Page 239 - 240



Saw blades ★★★★★

For removing grouting between tiles to a width of 1.3 mm and a depth of 12 mm, ideal for working into corners, plunge-cutting into the material and flat surface work, for example cutting out damaged tiles, and for milling channels for concealed pipework.

Page 240



Rasp ★★★★★

Rasps and removes mortar, tile adhesive and carpet residues, also for coarse surface preparation and smoothing of filler, concrete, stone and wood, for use on surfaces right into corners, narrow openings and up to edges, for use on machines with and without dust extraction.

Page 241



Scraper ★★★★★

Hard or flexible, for scraping hard and soft materials, removes foam carpet backing residue, old and damaged silicone or acrylic beads or loose flaking paint on wood and metal.

Page 241



Sets ★★★★★

Tile repair set 3-piece:
for tile, mortar and grouting repair
Flooring and installation set, 4-piece:
for carpentry and renovation work
Universal set 17-piece:
for woodworking, sanding and renovation work

Page 242 - 243

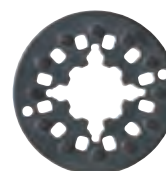

Universal adaptor ★★★★★

With the universal adaptor, you can fit the kwb multi-tool accessories to many popular multi-tools, Allrounders and multi function tools.







Page 243







EASY CUT jigsaw blades for wood, high carbon steel



EASY CUT jigsaw blades, high carbon steel, hardened, teeth cross- and hollow ground, for quick, accurate cuts, progressive toothting, tooth pitch varies from fine at the machine end to coarse at the point, so you can achieve a clean cutting edge both in thin and thick materials, with insertion teeth for problem-free plunge-cutting, for wood, blockboard, chipboard and fibreboard, light plastics.



Art.-No.		BOSCH number	Cont-ents	Length	Cut			Barcode
Cruciform fitting								
623020		T234X	2	116/93	Fine – Coarse		5	















Art.-No.		BOSCH number	Cont-ents	Length	Cut			Barcode
Universal shaft								
623030		U234X	2	116	Fine – Coarse		5	









Jigsaw blades for wood, Bi-metal



Jigsaw blades, bi-metal, hardened, teeth cross-, hollow and conical ground, quick, clean cutting, with insertion teeth for easy plunge cutting, for wood, hardwood, blockboard, fibreboard, chipboard, laminates, light plastics and glass fibre reinforced plastics.



Art.-No.		BOSCH number	Cont-ents	Length	Cut			Barcode
Cruciform fitting								
620120		T101B	2	100/75	Fine		10	
620220		T101D	2	100/75	Medium		10	
620320		T144D	2	100/75	Coarse		10	
620620		T101A0	2	77/50	Curve		10	

Art.-No.		BOSCH number	Cont-ents	Length	Cut			Barcode
Cruciform fitting, extra long								
623220		T344D	2	152	Coarse		10	
623320		T301CD	2	116/93	Coarse / long		5	

Jigsaw blades for wood, Bi-metal



Art.-No.		BOSCH number	Cont-ents	Length	Cut			Barcode
trade pack								
620125	2,5	T101B	5	100/75	Fine		6	
620225	4	T101D	5	100/75	Medium		6	
620325	4	T144D	5	100/75	Coarse		6	
620625	1,35	T101AQ	5	77/50	Curve		6	

Art.-No.		BOSCH number	Cont-ents	Length	Cut			Barcode
Universal shaft								
620130	2,35	U101B	2	100/80	Fine		10	
620230	4	U101D	2	100/80	Medium		10	
620330	4	U144D	2	100/80	Coarse		10	
620630	1,35	U1A0	2	70/50	Curve		10	

Art.-No.		BOSCH number	Cont-ents	Length	Cut			Barcode
Universal fitting, trade pack								
620135	2,5	U101B	5	100/80	Fine		6	
620235	4	U101D	5	100/80	Medium		6	
620635	1,35	U1A0	5	70	Curve		6	



Jigsaw blades for wood, conical ground, Bi-metal



Art.-No.		BOSCH number	Cont-ents	Length	Cut			Barcode
Cruciform fitting								
621020	2,5	T101BF	2	100/75	Fine		10	

Jigsaw blades, bi-metal, hardened, teeth cross-, hollow and conical ground, quick, clean cutting, with insertion teeth for easy plunge cutting, for wood, hardwood, blockboard, fibreboard, chipboard, laminates, light plastics and glass fibre reinforced plastics.



... always the appropriate accessories for your machine!

Jigsaw blades for wood, high carbon steel



Jigsaw blades, high carbon steel, hardened, ground teeth, extra rigid blade, for specially fast, straight and true cuts even in thick material, for wood, thick construction timber, blockboard, chipboard and fibreboard, light plastics, doors and kitchen worktops up to 50mm thick.



Art.-No.		BOSCH number	Cont-ents	Length	Cut			Barcode
Cruciform fitting								
620420		T144DP	2	100	Coarse		10	4 009316 204207

Art.-No.		BOSCH number	Cont-ents	Length	Cut			Barcode
trade pack								
620425		T144DP	5	100	Coarse		6	4 009316 204252

Jigsaw blades for wood, downcut, high carbon steel



Jigsaw blades, downcut, optimal for clean and true cuts when working on material from the visible finished side, high carbon steel, hardened, ground teeth, for quick, accurate and clean cutting, for wood, plywood, chipboard, blockboard and fibreboard, laminated and kitchen worktops up to 30mm thickness.

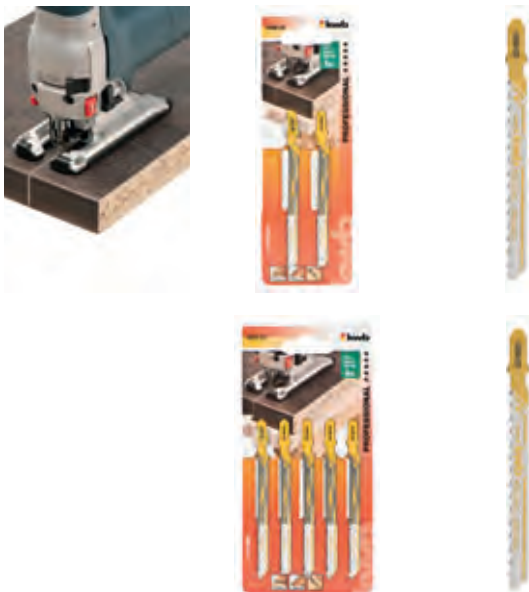





Art.-No.		BOSCH number	Cont-ents	Length	Cut			Barcode
Cruciform fitting								
620820		T101BR	2	100/75	Fine		10	4 009316 208205

Art.-No.		BOSCH number	Cont-ents	Length	Cut			Barcode
Cruciform fitting, trade pack								
620825		T101BR	5	100/75	Fine		6	4 009316 208250

Jigsaw blades

Jigsaw blades for wood, downcut, high carbon steel









Art.-No.		BOSCH number	Cont-ents	Length	Cut			Barcode
Universal fitting								
620830	2,5	U101BR	2	100	Fine		10	







Jigsaw blades for wood and laminates, Bi-metal







Art.-No.		BOSCH number	Cont-ents	Length	Cut			Barcode
Cruciform fitting								
620520	1,7	T101BIF	2	83	Fine		10	
620920	1,4	T101AOF	2	83	Curve		10	

Jigsaw blades, bi-metal, hardened, teeth cross- and hollow ground, quick, clean cutting, with plunge cutting teeth for simple insertion, for laminates, plastic coated and composite boards, wood, hardwoods.



Art.-No.		BOSCH number	Cont-ents	Length	Cut			Barcode
Cruciform fitting, trade pack								
620525	1,7	T101BIF	5	83	Fine		6	



Art.-No.		BOSCH number	Cont-ents	Length	Cut			Barcode
Universal fitting, trade pack								
620535	1,7	U1BIF	5	70	Fine		6	







Jigsaw blade set for wood and laminates, Bi-metal



Jigsaw blade set, bi-metal, hardened, teeth cross- and hollow-ground, quick, clean cutting, with insertion teeth, for problem-free plunge cutting, for laminates, plastic coated and composite boards, wood, hardwoods.







Art.-No.		BOSCH number	Contents	Length	Cut			Barcode
Cruciform fitting								
622320		1,71,4 T101BIF + 1x T101AO	3	83	2x Fine 1x Curve		10	 4 009316 223208

Diamond coated jigsaw blades for tiles and ceramics



Diamond jigsaw blades for tiles and ceramics. Diamond particle coated, ideal for clean, accurate cuts in hard tiles, porcelain, glass, marble, quarry tiles, travertin, tiles, fibreglass and cement board. Craftsman quality, for long life in building and renovation work.



Art.-No.	BOSCH number	Contents	Length	Cut			Barcode
Cruciform fitting							
622220	T150RD	1	83/56	Fine		1	 4 009316 222201







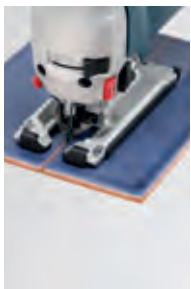

Jigsaw blades for tiles and ceramics, tungsten carbide coated



Jigsaw blades for tiles and ceramics, tungsten carbide gritted, for wall tiles, ceramics, brick, glass and cast iron, up to 15mm thick.







Art.-No.	BOSCH number	Contents	Length	Cut			Barcode
Cruciform fitting							
622121	T150RIFF	1	77/50	Fine		5	 4 009316 221211
621921	T130RIFF	1	77/50	Coarse		5	 4 009316 219218

Jigsaw blades

EASY CUT jigsaw blades for metal, Bi-metal











Art.-No.		BOSCH number	Cont-ents	Length	Cut			Barcode
Cruciform fitting								
624020	1,2-26	T123XF	2	100	Fine – Coarse		5	

EASY CUT jigsaw blades, bi-metal, hardened, teeth milled and set, for quick, accurate cuts, progressive toothting, tooth pitch varies from fine at the machine end to coarse at the point, so you can achieve a clean cutting edge both in thin and thick materials, for thin and thick sheet metal (1.5-10mm), tubes, profiles, in metal and aluminium up to 30mm.











Jigsaw blades for metal, Bi-metal









Art.-No.		BOSCH number	Cont-ents	Length	Cut			Barcode
Cruciform fitting								
621120	1,2	T118AF	2	77/50	Fine		10	
621220	2	T118BF	2	77/50	Medium		10	
621320	3	T127DF	2	75	Coarse		10	

Jigsaw blades, bi-metal, hardened, highly flexible, teeth milled and set, for sheet metal and mesh up to 3mm thick, for tubes and profiles up to 30mm, non-ferrous metal, aluminium and plexiglas.



Art.-No.		BOSCH number	Cont-ents	Length	Cut			Barcode
trade pack								
621125	1,2	T118AF	5	77/50	Fine		6	
621225	2	T118BF	5	77/50	Medium		6	
621325	3	T127DF	5	75	Coarse		6	



Art.-No.		BOSCH number	Cont-ents	Length	Cut			Barcode
Universal fitting								
621130	1,2	U118AF	2	70/50	Fine		10	
621230	2	U118BF	2	70/50	Medium		10	









Jigsaw blades for metal, HSS



Jigsaw blades, HSS, teeth milled and set, for sheet metal and mesh up to 3mm thick, for pipes and profiles up to 65mm, non-ferrous metal, aluminium, sandwich material and Plexiglas.









Art.-No.		BOSCH number	Cont-ents	Length	Cut			Barcode
Cruciform fitting, extra long								
624220		T318A	2	132	Medium		5	

EASY CUT jigsaw blades UNIVERSAL, Bi-metal



EASY CUT jigsaw blades UNIVERSAL, bi-metal, hardened, teeth milled and set, for quick, accurate cuts, progressive toothing, tooth pitch varies from fine at the machine end to coarse at the point, so you can achieve a clean cutting edge both in thin and thick materials, with insertion teeth for problem-free plunge-cutting, for wood with nails up to 65mm thick, wooden materials, plastics, metal sheet, pipes and profiles, and aluminium, up to 10mm diameter.







Art.-No.		BOSCH number	Cont-ents	Length	Cut			Barcode
Cruciform fitting								
624820		T345XF	2	132/105	Fine – Coarse		5	

Jigsaw blade set, 6-piece



Jigsaw blade set 6-piece, 4 woodworking blades, high carbon steel, hardened, teeth cross- and hollow ground, quick, clean cutting, with insertion teeth for problem-free plunge cutting, for wood, chipboard, blockboard and fibreboard, light plastics; 2 bi-metal metalworking blades, highly flexible, teeth milled and set, for sheet metal and mesh up to 3mm thick, for tubes and profiles up to 30mm, non-ferrous metal, aluminium and Plexiglas, in plastic cassette.

Art.-No.	Contents			Barcode
Cruciform fitting, plastic box				
625620	6pc. set HCS / woodworking, 2x fine, 1x coarse, 1x curve, Bi-Metal / metal cutting, 2x medium		6	



Jigsaw blades

Jigsaw blade set, 6-piece



Art.-No.	Contents			Barcode
Universal fitting, plastic box				
625630	6pc. set HCS / woodworking, 2x fine, 1x coarse, 1x curve, Bi-Metal / metal cutting, 2x medium		6	



Jigsaw blades for wood, special plunge cutting teeth, high carbon steel



Art.-No.		BOSCH number	Cont-ents	Length	Cut			Barcode
Cruciform fitting								
610120	2	T111B	2	100	Fine		10	
610220	3	T111C	2	100	Medium		10	
610320	4	T111D	2	100	Coarse		10	
610620	2	T119B0	2	76	Curve		10	

Jigsaw blades, high carbon steel, teeth milled and set, for softwood, up to 50mm thick, blockboard, chipboard and fibreboard.



Art.-No.		BOSCH number	Cont-ents	Length	Cut			Barcode
trade pack								
610125	2	T111B	5	100	Fine		6	
610225	3	T111C	5	100	Medium		6	
610325	4	T111D	5	100	Coarse		6	



Art.-No.		BOSCH number	Cont-ents	Length	Cut			Barcode
Universal fitting								
610130	2	U111B	2	91	Fine		10	
610230	3	U111C	2	91	Medium		10	
610330	4	U111D	2	100	Coarse		10	























Jigsaw blades for metal, HSS









Jigsaw blades, HSS steel, hardened, teeth milled and set, for thin sheet metal.



Art.-No.		BOSCH number	Cont-ents	Length	Cut			Barcode
Cruciform fitting								
611120		T118G	2	76	Fine		10	
611220		T118A	2	76	Medium		10	
611320		T118B	2	76	Coarse		10	

Art.-No.		BOSCH number	Cont-ents	Length	Cut			Barcode
trade pack								
611225		T118A	5	76	Medium		6	
611325		T118B	5	76	Coarse		6	





Art.-No.		BOSCH number	Cont-ents	Length	Cut			Barcode
Universal fitting								
611230		U18A	2	70	Medium		10	





Jigsaw blade set, 10-piece



Jigsaw blade set 10-piece, 8 woodworking blades, high carbon steel, hardened, teeth milled and ground, for softwoods up to 50mm thick, chipboard, blockboard and fibreboard, 2 metalworking blades, teeth milled and set, for thin sheet metal, in CD round box with convenient single blade dispenser.







Art.-No.	Contents			Barcode
Cruciform fitting				
617020	HCS / woodworking 2 x fine, 2 x medium, 2 x coarse, 2 x curve, HSS / metalworking 2 x fine		4	

Art.-No.	Contents			Barcode
Universal shaft				
617030	HCS / woodworking 2 x fine, 2 x medium, 2 x coarse, 2 x curve, HSS / metalworking 2 x fine		4	

Reciprocating saw blades

EASY CUT reciprocating saw blades for wood, high carbon steel





Art.-No.		BOSCH number	Cont-ents	Length	Cut			Barcode
trade pack								
576900	2,4 - 4,0	S22345X	2	205/180	Fine - Coarse		2	

EASY CUT reciprocating saw blades for wood, high carbon steel, hardened, teeth precision ground and set, for quick, progressive toothing, tooth pitch varies from fine at the machine end to coarse at the point, so you can achieve a clean cut edge both in thin and thick materials, for construction timber and wooden structures up to 150mm thick, blockboard and MDF up to 60mm thick, plywood and sheet plastic up to 100mm thick, 1/2" shank for all standard reciprocating and sabre saws.



Reciprocating saw blades for wood, high carbon steel







Art.-No.		BOSCH number	Cont-ents	Length	Cut			Barcode
hard-/ softwood, construction timber, laminates, curved cuts								
576600	4	S644D	2	153/130	Medium		2	

Reciprocating saw blades for wood, high carbon steel, hardened, teeth precision ground and set, for quick, progressive toothing, tooth pitch varies from fine at the machine end to coarse at the point, so you can achieve a clean cut edge both in thin and thick materials, for construction timber and wooden structures up to 100mm thick, blockboard and MDF up to 60mm thick, plywood and sheet plastic up to 100mm thick, 1/2" shank for all standard reciprocating and sabre saws.



Reciprocating saw blades for wood, high carbon steel



Art.-No.		BOSCH number	Cont-ents	Length	Cut			Barcode
hard-/ softwood, construction timber, laminates								
576500	4	S1411D	2	305/283	Medium		2	





Reciprocating saw blades for wood, high carbon steel, hardened, teeth precision ground and set, for quick, progressive toothing, tooth pitch varies from fine at the machine end to coarse at the point, so you can achieve a clean cut edge both in thin and thick materials, for construction timber and wooden structures up to 100mm thick, blockboard and MDF up to 60mm thick, plywood and sheet plastic up to 100mm thick, 1/2" shank for all standard reciprocating and sabre saws.



Reciprocating saw blades for wood, high carbon steel







Reciprocating saw blades for wood, high carbon steel, hardened, teeth precision ground and set, for quick, progressive toothting, tooth pitch varies from fine at the machine end to coarse at the point, so you can achieve a clean cut edge both in thin and thick materials, for construction timber and wooden structures up to 100mm thick, blockboard and MDF up to 60mm thick, plywood and sheet plastic up to 100mm thick, 1/2" shank for all standard reciprocating and sabre saws.

Art.-No.		BOSCH number	Cont-ents	Length	Cut			Barcode
hard-/ softwood, construction timber, firewood								
576700	8,5	S1111K	2	228/205	Coarse		2	



Reciprocating saw blades for wood, high carbon steel





Reciprocating saw blades for wood, high carbon steel, hardened, teeth precision ground and set, 1/2" shank for all standard reciprocating and sabre saws, specially for firewood, wet and dry wood up to 190mm thick, construction timber and hardwoods.

Art.-No.		BOSCH number	Cont-ents	Length	Cut			Barcode
hard-/ softwood, construction timber, dry firewood								
576300	8,5	S1542K	2	240/218	Extra Coarse		2	



Reciprocating saw blades for wood, high carbon steel

Reciprocating saw blades for wood, high carbon steel, hardened, teeth precision ground and set, skip toothing, 1/2" shank for all standard reciprocating and sabre saws, specially for green wood, pruning up to 190mm diameter, firewood, wet and dry wood, construction timber and hardwoods.





Art.-No.		BOSCH number	Cont-ents	Length	Cut			Barcode
hard-/ softwood, pruning, green firewood, skip teeth								
576400	5	S1531L	2	240/218	Coarse		2	



Reciprocating saw blades

Reciprocating saw blades, multi-material, HAS steel



Art.-No.	 BOSCH number	Cont-ents	Length	Cut			Barcode
wood, wood with nails, non-ferrous metals, plasterboard							
578400	2,5 S811H	2	153/130	Medium		2	

HAS steel for woodworking and non-ferrous metals



kwb-Info

A safer job

It's always a good idea to wear protective gloves when your hands could possibly be injured, for example in building work with sharp-edged objects etc.

For all types of work, a safe grip and wearer comfort are the prime requirements for the correct type of glove.







You can find further information in our kwb **Personal Protection leaflet**, or on the Internet at www.kwb.eu.



EASY CUT reciprocating saw blades for metal, Bi-metal



EASY CUT reciprocating saw blades for metal, Bi-metal, hardened, teeth milled and set, 1/2" shank for all standard reciprocating and sabre saws, for quick accurate cutting, progressive toothing, tooth pitch starts from fine at the shaft end to coarse near the tip, so you can always achieve a clean cut whether in thick or thin material, for thin and thick sheet up to 8mm thick, pipes, strong profiles up to 100mm.





Art.-No.		BOSCH number	Cont-ents	Length	Cut			Barcode
thin and thick metals, clean cut								
579900	1,75-3,0	S123XF	2	153/130	Fine – Coarse		2	 4 009315 799001



Reciprocating saw blades for metal, Bi-metal



Reciprocating saw blades for metal, Bi-metal, highly flexible, teeth milled and set, 1/2" shank, for wood with nails, metal up to 150mm thick, pallet repair, sheet steel, pipes and aluminium profiles up to 12mm thick, allows flush cutting thanks to its flexibility.



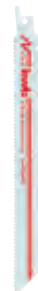
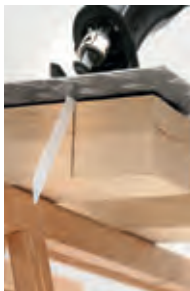





Art.-No.		BOSCH number	Cont-ents	Length	Cut			Barcode
sheet metal, tubes, profiles, plastic, wood with nails; flexible								
577800	2,5	S1022HF	2	205/180	Medium		2	 4 009315 778006



Reciprocating saw blades for metal, Bi-metal



Reciprocating saw blades for metal, Bi-metal, highly flexible, teeth milled and set, 1/2" shank, for wood with nails, metal up to 150mm thick, pallet repair, sheet steel, pipes and aluminium profiles up to 12mm thick, allows flush cutting thanks to its flexibility.





Art.-No.		BOSCH number	Cont-ents	Length	Cut			Barcode
steel, mild steel, profiles, sheet metal, aluminium, plastic								
577500	1,4	S918EF	2	153/130	Fine		2	 4 009315 775005
579100	2	S922BF	2	153/130	Medium		2	 4 009315 791005
577400	2,5	S918HF	2	153/130	Coarse		2	 4 009315 774008



Reciprocating saw blades

Reciprocating saw blades for metal, Bi-metal







Art.-No.		BOSCH number	Cont-ents	Length	Cut			Barcode
Steel, mild steel, non-ferrous metal, aluminium, profiles, tubes; flexible								
579500	2	S1122BF	2	228/205	Medium		2	

Reciprocating saw blades for metal, Bi-metal, highly flexible, teeth milled and set, 1/2" shank, for wood with nails, metal up to 150mm thick, pallet repair, sheet steel, pipes and aluminium profiles up to 12mm thick, allows flush cutting thanks to its flexibility.



EASY CUT reciprocating saw blades UNIVERSAL, Bi-metal







Art.-No.		BOSCH number	Cont-ents	Length	Cut			Barcode
wood with nails, metal, sheet metal, tubes, aluminium profile, plastic								
578900	8,2 - 4,6	S3456XF	2	205/180	Fine - Coarse		2	

EASY CUT reciprocating saw blades, UNIVERSAL, Bi-metal, hardened, teeth milled and set, 1/2" shank to fit all standard reciprocating and sabre saws, for wood with nails, metal, boards up to 150mm thick, sheet metal, pipes, profiles and aluminium profiles up to 18mm thick, glass reinforced plastics up to 150mm thick



Diamond coated reciprocating saw blades for tiles and ceramics



Art.-No.	BOSCH number	Contents	Length	Cut			Barcode
578300	S1050RD	1	200	Medium		1	

Diamond reciprocating saw blades, for tiles and ceramics, diamond particle coated, ideal for clean accurate cuts in porcelain, hard tiles, glass, marble, floor tiles, travertin, fibreglass and cement board, craftsman quality, for long life in building and renovation work.



Saw blades for lightweight blocks



The ideal solution for clean cutting of lightweight blocks, fibre cement and red brick.



Art.-No.	Contents			Barcode
577100	9" x 240 mm		1	4 009315 771007

Saw blades for lightweight blocks



The ideal solution for clean cutting of lightweight blocks, fibre cement and red brick.







Art.-No.		BOSCH number	Cont-ents	Length	Cut			Barcode
577300	12,7	S2243HM	1	455/400	Coarse		1	4 009315 773001

Multitool accessories

CRV plunge-cutting sawblade with Japanese tooting



For especially clean and fast cuts up to a depth of 48 mm (34 mm width) into hard wood, soft wood, plasterboard, laminate, parquet, plastic etc. Easy plunging anywhere into the material. E.g. problem-free plunge cuts in parquet floors, natural wood worktops for ventilation grilles, in cupboards or plasterboard for access to electrical outlets.









Art.-No.	Contents			Barcode
709164	Plunge-cutting sawblade for wood with Japanese tooting		10	



CRV plunge-cut saw blade



Cuts wood up to 28 mm (10 mm), 48 mm (22 mm, 34 mm) for wood, plasterboard, cardboard and soft materials. Easy plunging into the material at any position, for cutting into wood, boards, laminate, parquet, plastic. E.g. plunge cutting into kitchen worktops for air grilles, in cupboards or plasterboard for problem-free access to power outlets.







Art.-No.	Contents			Barcode
709140	Plunge-cut saw blade, 10 mm		1	
709142	Plunge-cut saw blade, 22 mm		1	
709144	Plunge-cut saw blade, 34 mm		1	



Universal plunge-cutting saw blade, Bi-metal



Cuts coated wood up to 50 mm. Easy plunging into the material at any position, for cutting into plastic, glass fibre, sheet metal up to 2 mm, copper pipes, aluminium pipes and profile sections. E.g. flush-cutting of protruding nails from wood or copper pipe from the wall. Trouble-free trimming of door frames when installing laminate flooring and parquet. Smooth plunge-cutting into kitchen worktops for air grilles, in cupboards or plasterboard for access to power outlets. Effortless cutting into glass fibre for boat building or into plastic elements. Easy cut-outs in thin metal sheets and non-ferrous metals.

Art.-No.	Contents			Barcode
709240	Plunge-cut saw blade, 10 mm		1	
709242	Plunge-cut saw blade, 22 mm		1	







HSS plunge-cutting saw blade, semi-circular

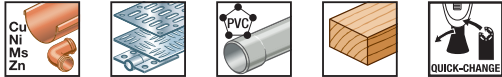

Easy plunging into the material at any position, for cutting into plastic, glass fibre, sheet metal up to 2 mm, copper pipes, aluminium pipes and profile sections. E.g. flush-cutting of protruding nails from wood or copper pipe from the wall. Trouble-free trimming of door frames when installing laminate flooring and parquet. Smooth plunge-cutting into kitchen worktops for air grilles, in cupboards or plasterboard for access to power outlets. Effortless cutting into glass fibre for boat building or into plastic elements. Easy cut-outs in thin metal sheets and non-ferrous metals.







Art.-No.	Contents			Barcode
709440	Plunge-cut saw blade, HSS, 87 mm		10	 4 009317 094401

Saw blade, half-round, tungsten carbide gritted

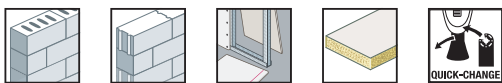

Mills joints of tiles with a cutting width of 2.2 mm. Ideal for working into the corners, plunging into the material and working on flush surfaces. E.g. for detaching damaged joints for tiles or replacing a damaged tile, milling of grooves in sand-lime brick or aerated concrete for cable ducts or milling of pipes for concealed wiring.



Art.-No.	Contents			Barcode
709542	Saw blade, HM, 87 mm		10	 4 009317 095422

Diamond coated saw blade, half-round



Mills joints of tiles with a cutting width of 1.3 mm. Ideal for working into the corners, plunging into the material and working on flush surfaces. E.g. for detaching damaged joints for tiles or replacing a damaged tile, precise cutting of small apertures in soft tiles for pipe connections or corners, milling of grooves in sand-lime brick or aerated concrete for cable ducts or milling of pipes for concealed wiring.

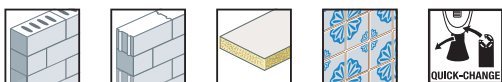



Art.-No.	Contents			Barcode
709546	Diamond saw blade, 65 mm		10	 4 009317 095460

Multitool accessories

Tungsten carbide gritted rasp, Delta shape



Grinds and removes mortar, tile and carpet adhesive residue. Also for rough grinding and smoothing of filler, grout, concrete, masonry, wood, eg for removing mortar or adhesive from damaged tiles, remnants of foam carpet backing, or for surface preparation on concrete, masonry and wood. Can be used right into corners, narrow gaps and angles. Suitable for use with machines with or without dust extraction.

Art.-No.	Contents			Barcode
709544	TC rasp, Delta, 80 mm		10	



Scraper, rigid



For use into corners, narrow spaces and edges. Can be used with machines with or without dust extraction.

Art.-No.	Contents			Barcode
709640	Scraper, rigid		10	



Scraper, flexible



For scraping of soft materials, silicone or acrylic joints, residual glue from bonding, paint residues. E.g. removal of residual glue from old floorcoverings, foam carpet backing residue, old or damaged silicone or acrylic joints or loose flaking paint from wood and metal.

Art.-No.	Contents			Barcode
709642	Scraper, flexible		10	



Delta backing pad, hook and loop, 93mm



Quick, easy changeover of punched sanding discs, scouring pads or felt polishing wheels with QUICK STICK hook and loop fixing. Compatible accessories in the kwb range: Aluminium oxide sandpaper for wood and metal in various grits, Silversand sandpaper for wood and paint, scouring pads for matt finishing and smoothing of wood fibres, felt polishing wheels for polishing wood, metal, non-ferrous metals.





Art.-No.	Contents			Barcode
709940	Delta backing pad, hook and loop, 93mm		10	 4 009317 099406



Tile repair set, 3-piece



Universal use for tile and mortar repair or refurbishment work, for example damaged grouting between tiles, or replacing broken tiles, precision cutting of small cut-outs in ceramic tiles for pipes or to fit corners, removing old mortar and tile adhesive from tiles, removing old carpet remnants or coarse surface preparation of concrete, stone and wood, milling grooves in brick or aerated concrete blocks for conduit or pipework to be concealed under plaster.



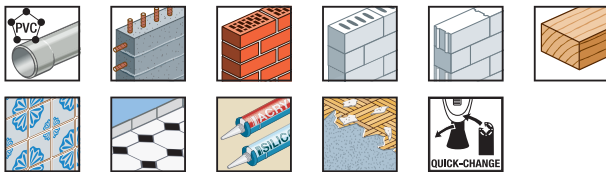

Art.-No.	Contents			Barcode
708600	65 mm semi-circular, carbide grit coated 80 mm Delta, carbide grit coated 65 mm semi-circular, diamond particle coated		10	 4 009317 086000



Floor and installation kit, 4-piece



Universal use in carpentry and refurbishment, for example clean flush cuts in parquet, laminate or sound absorbing flooring, precise trimming of doors during laminated floor laying, shortening aluminium connector bars, flush cutting off of projecting nails or copper pipes from walls. Problem-free plunge cutting in kitchen worktops for ventilation grilles, in cupboards or plasterboard for access to electrical sockets, dust-free cuts in fibreglass for boatbuilding or in plastics. Simple removal of old putty on window frames. Easy cutting out in thin sheet steel and non-ferrous metal.

Art.-No.	Contents			Barcode
708800	87 mm semi-circular HSS saw 22 x 48 mm metal saw blade BIM28 x 48 mm wood saw blade CRV26 x 52 mm scraper		10	 4 009317 088008

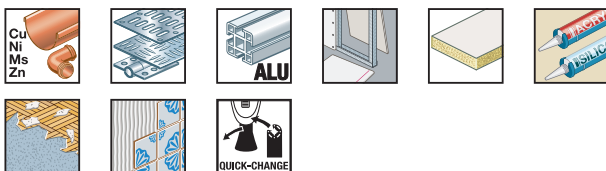





Multitool accessories

OMT Universal adapter



With the Universal Adaptor, the kwb Allrounder/ multitool accessories can be used with many popular multitools. The Universal Adaptor can be used with the following machines: Bosch PMF 180 E, GOP 10.8 V-Li, EINHELL RT-MG 200 E RED, RT-MG 108 Li RED, BT-MG 220 E, BT-MG 180, DREMEL Multi-Max, ERGOTOOLS Plattfield E-MG 250 E, LUX TOOLS AMF 12 Li, Mac Alister MMT108, PARKSIDE, FEIN Multimaster Ø 10 mm, Rockwell/Works Sonicrafter, Craftsman Multi-Tool, Mastercraft Multi-Cutter.



Art.-No.	Contents			Barcode
708700	OMT Universal adapter		10	







Universal kit, 17 items























































Can be used for all kinds of wood, sanding and repair work. E.g. clean cutting of laminate flooring, or sound-proofing flooring, exact, flush trimming of door frames for laminate floor installation, trimming of aluminium connector bars, flush-cutting of protruding nails from wood or copper pipe from the wall. Smooth plunge-cutting into kitchen worktops for air grilles, in cupboards or plasterboard for access to power outlets. Effortless cutting into glass fibre for boat building or into plastic elements. Problem-free removal of old putty in window frames. Easy cut-outs in thin sheet metal and non-ferrous metals. Removal of residual tile adhesive for touch-up work, concrete or mortar residues for masonry work, residual glue from carpeting removal or removal of old varnish and underfloor coatings. Sanding work for wood, varnish, matt finishing and removal of wood fibres, polishing of wood, metal and non-ferrous metal.































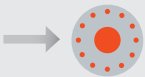





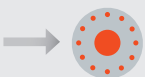













Art.-No.	Contents			Barcode
708900	87 mm semi-circular HSS saw 22 x 48 mm metal saw blade BIM28 x 48 mm wood saw blade CRV 26 x 52 mm scraper 93 mm hook and loop backing pad 6 pc. hook and loop sanding pads wood & metal 6 pc. hook and loop sanding pads wood & paint		10	

... always the appropriate accessories for your machine!

Manufacturer / machine model	Machine fitting	Adaptor fitting	+	kwb Multitool Quick Change	=	Fits!
AEG BWS 12 C		 Adaptor from your machine	+		=	
ALDI (Workzone/Topcraft)			+		=	
ALPHA TOOLS A180			+		=	
BATAVIA ZZ 9506, TD 8501			+		=	
BLACK & DECKER MT250KA, MT300KA, BD200MTB		 Adaptor from your machine	+		=	
BOSCH PS50-2A, MX25EC-21, PMF 180 E, PMF 190 E, PMF 10,8 Li, PMF 250 CES, GOP 250 CE			+		=	
CRAFTSMEN Nextec 5910 12 V, Nextec 174J8		 Adaptor from your machine	+		=	
CRAFTSMEN Craftsman G2 Cordless Nextec Tool-Free Multitool #67537 Variable Speed Oscillating Multifunction Power Tool #67256 base model fixed speed Oscillating Multifunction Power Tool #67707 12 Volt Lithium-Ion Oscillating Multifunction Power Tool #67538 Variable Speed Multifunction Air Tool #68303 Fixed speed Oscillating Multifunction Power Tool #68861 Fixed speed Oscillating Multifunction Power Tool		 Adaptor from your machine	+		=	
DREMEL MM20, Multi-Max TM 8300-q, MM40 (Quick Change)			+		=	
EINHELL RT-MG 200 E, RT-MG 10.8Li, BT-MG 180, BT-MG 220 E			+		=	
ERGOTOOLS Pattfield E-119 250 E			+		=	
FEIN MULTIMASTER FMM 250		 kwb-Adaptor (708700)	+		=	
FERM OTM-1001, OTM-1003		 kwb-Adaptor (708700)	+		=	
LIDL (PARKSIDE) PMFV 280			+		=	
LIDL (PARKSIDE) PMFV 280 A2, PDMT 6.2 A1		 Adaptor from your machine	+		=	

Multitool accessories

Manufacturer / machine model	Machine fitting	Adaptor fitting	+	kwb Multitool Quick Change	=	Fits!
LUX TOOLS AMF 12 Li, MFW 220		 <small>Adaptor from your machine</small>	+		=	
MAC ALLISTER 2426-22MM12, MMT 108		 <small>Adaptor from your machine</small>	+		=	
MAKITA BTM40, BTM50			+		=	
MASTERCRAFT BWS 12 C			+		=	
MEISTER BASIC BMT-250			+		=	
MILWAUKEE 2426-22MM12			+		=	
PORTER CABLE 250MT, PC250MTK, PCL120MT, PCE605, PCCK510LA, PCC510B		 <small>Adaptor from your machine</small>	+		=	
RIGID JobMax			+		=	
ROCKWELL RK5100K, RK5101K, RK5102K, RK5105K, RK5106K, RK5107K, RK5108K		 <small>Adaptor from your machine</small>	+		=	
RYOBI RMT 12011 L, RMT 18011 L, RMT 1801 M		 <small>Adaptor from your machine</small>	+		=	
SKIL Multi-Tasker 147D, 1400 2.0 Amp, 1470 AA			+		=	
STANLEY FATMAX FME600 Oscillating Tool, FME600K Oscillating Tool Kit		 <small>Adaptor from your machine</small>	+		=	
WESTFALIA TD 8501			+		=	
WORX Worx 250W Sonicrafter WX671, Worx 12V Sonicrafter, Worx Sonicrafter Pro 250 W, Worx Sonicrafter Pro 12V Li WX673		 <small>Adaptor from your machine</small>	+		=	
KWB ADAPTOR (708700) Suitable for many types of machine. Two different adaptors in one.		 <small>kwb-Adaptor</small>	+		=	

... always the appropriate accessories for your machine!





CIRCULAR SAW BLADES

Circular saw blades



Quickly and easily find the right circular saw blade in our comprehensive application chart:

Are you searching by manufacturer or machine model?
Then go to pages 250 - 259.

Or are you searching by blade size required?

- for hand-held circular saws pages 260 - 267
- for bench and table saws pages 268 - 274
- for chop- and mitre saws pages 275 - 276

Programme overview / qualities



EASY CUT multi material blade, Ø 150 - 350 mm ★★★★★

Tungsten carbide tipped, precise, clean cut. Special variable pitch teeth, for hand-held circular saws, bench and table saws as well as chop- and mitre saws. Asymmetrical toothting for up to 30% noise reduction. For chipboard, construction timber with nails, metal and aluminium profiles as well as plastics including Plexiglas.

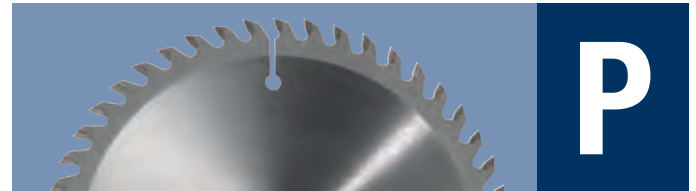
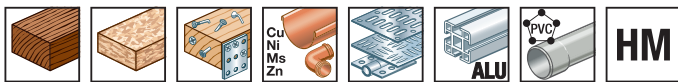

Clean cut blades, Ø 125 - 230 mm ★★★★★

Tungsten carbide tipped, quick, clean cut with break-out free cut edges. Fine teeth, for hand-held circular saws. For solid wood, laminated boards (work surfaces and kitchen worktops), blockboard, chipboard and fibreboard as well as glass fibre reinforced plastics.

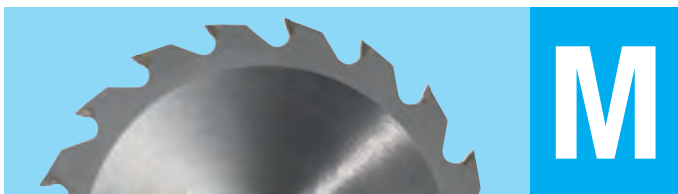
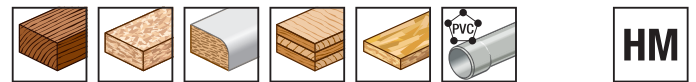

Chipboard blade, Ø 125 - 230 mm ★★★★★

Tungsten carbide tipped, quick, clean cut, regular teeth, for hand-held circular saws. For solid wood, laminated boards (work surfaces and kitchen worktops), blockboard, chipboard or fibreboard and glass fibre reinforced plastics.

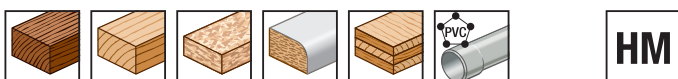

Construction wood blades, Ø 250 - 500 mm ★★★★★

Tungsten carbide tipped, quick, coarse cut. Coarse teeth, for bench and table saws. For solid wood, blockboard, chipboard, high density fibreboard and glass fibre reinforced plastics.

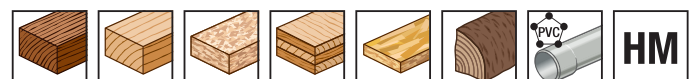

kwb-Info

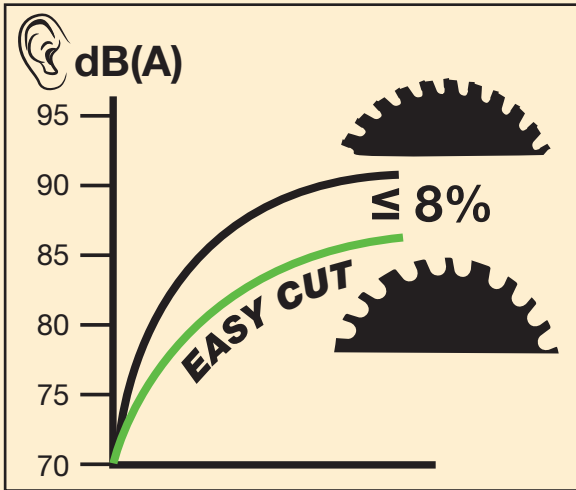

EASY CUT quiet multi-material circular saw blades

- Asymmetrical toothing
- Vibration-free running
- Less recoil from the saw
- Operator protecting, safe working
- Clean, perfect cut
- Up to 30% quieter



Moulding blade, Ø 125 - 500 mm ★★★★★
 Chrome vanadium, fine, accurate cut. Pointed teeth, for hand-held circular saws, bench and table saws. For softwood, plywood, panels and mouldings.

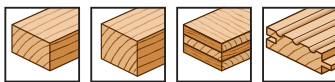

CV

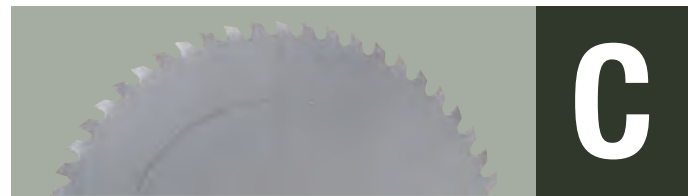

Logging blade, Ø 250 - 500 mm ★★★★★
 Chrome Vanadium, fast, coarse cut. Coarse teeth, for saw benches and table saws. For firewood, construction timber and boards.

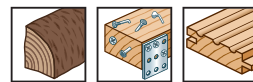

CV



Crosscut blad, Ø 210 - 300 mm ★★★★★
 Chrome Vanadium, fine, accurate cut. Fine teeth, for mitre and chopsaws. For softwood, plywood, panels and profiles.

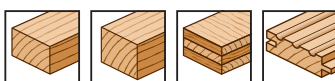

CV

kwb-Info

CV

Chrome Vanadium

Particularly suitable for long grain and cross cuts in natural and laminated wood. For easy and clean cuts.

HM

Tungsten carbide tipped

Especially hardwearing and stays sharp longer. The more teeth on the blade, the finer the cut.

... always the appropriate accessories for your machine!

Manufacturer/ machine model	Blade Ø mm	Bore size Ø mm	Applications							kwb quick reference number	Part-No.
			E	P	M	K	B	C	A		
AEG											
Circular saws											
HK 125, 125A, 125B, 125H	125	20		✓						13	5813
HK 40	140	20		✓						28	5828
HK 45, 45A, 46, 46N, 46S, HK 50, 52, 737, HKS 52	150	20	✓		✓		✓			35	5835
AHK 52 Akku	150	20	✓		✓		✓			35	5835
HK 55A, 55B, 160A, 160B, K 55, 55S, 55SE	160	20	✓		✓		✓			45	5845
HK 65, 65A, 66, 190, HKS 65, 65A, 66, HKE 66, K 66SE	190	30	✓		✓		✓			69	5869
HKSE 66, KS 66S, K 66S	190	30	✓		✓		✓			69	5869
HK 200, 201	200	30	✓				✓			74	5874
HK 75, 75A, HKS 75	210	30	✓	✓	✓		✓			78	5878
35, HKS 85	230	30	✓				✓			85	5885
Bench and table saws											
M 65	250	30	✓		✓	✓	✓	✓		93	5893
AL-KO											
Bench and table saws											
Holzmeister H, S, NHS, HS/3, HS/4	315	30	✓		✓	✓	✓	✓		931	5931
W 450	450	30				✓	✓	✓		945	5945
W 500, W 50 Profi	500	30				✓	✓	✓		951	5951
ALPHA TOOLS											
Circular saws											
KS 210 / 2 Profi	210	30	✓	✓	✓		✓			78	5878
ATIKA											
Bench and table saws											
ATK 315H, BTA 90, HAT 315	315	30	✓		✓	✓	✓	✓		931	5931
ABH 400, ABK 400	400	30				✓	✓	✓		940	5940
ABH 450, ATU, BWK 450, ABK 450	450	30				✓	✓	✓		945	5945
ABH 500, BWK 500, ABK 500	500	30				✓	✓	✓		951	5951
BLACK & DECKER											
Circular saws											
DN 254, 55, 56, D 984, 985, D 2702, 2712	127	12,75			✓		✓			15	5815
BD 227, 228, 846, DN 227, DN 227H, KS 846, 840	140	12,75			✓		✓			23	5823
P 88-09	150	20	✓		✓		✓			35	5835
BD 228, 228CK, 2288L, SR 352, DN 228, 57, SR 352E, P 36-01	156	12,75	✓				✓			41	5841
BD 855, U 336, 975, 976, KS 855, 855N, GKS 54CE	160	16	✓		✓		✓			43	5843
M 336, 975, 976	160	16	✓		✓		✓			43	5843
HD 1200, 2062	180	20	✓		✓		✓			57	5857
BD 229, 865E, DN 229, 59, 820, HD 100, 1000, 1200P	184	16	✓	✓	✓		✓			61	5861
KS 865, 865KN, 865E, GD 60, P 37-03, 37-05, SEC 718, 2062, SR 300, 362E	184	16	✓		✓		✓			61	5861
BD 365	190	30	✓		✓		✓			69	5869
U 338, M 338	200	16	✓		✓		✓			71	5871
BD 800, 88, DN 800, 810, HD 2075S, KS 805, 810, 800,	210	30	✓	✓	✓		✓			78	5878
PS 174, P 38-02, SEC 818, SR 700	210	30	✓	✓	✓		✓			78	5878
HD 2086S, P 39-02, SEC 918	230	30	✓				✓			85	5885
Chop- and mitre saws											
BD 800, SR 700, KS 810, KS 800, HD 20755, KS 810 A	210	30	✓	✓						78	5878

Circular saw blades classified by Manufacturer/ machine model

Manufacturer/ machine model	Blade Ø mm	Bore size Ø mm	Applications							kwb quick reference number	Part-No.
			E	P	M	K	B	C	A		
BOSCH											
Circular saws											
PKS 40, 40S, S 43	130	16			✓		✓			18	5818
1551, 1559	140	20		✓						28	5828
GKS 12V Akku, PKS 416, GKS 12	150	16		✓	✓		✓			33	5833
GB 1923, PKS 46, S 1, S 33	150	16	✓	✓	✓		✓			33	5833
GKS 54, 54CE, 54C, PKS 54, 54CE	160	16	✓		✓		✓			43	5843
GKS 55, 55CE, PKS 55 A	160	20	✓		✓		✓			45	5845
1552, 1556, 1563, GKS 55	170	30	✓				✓			54	5854
0550, 1550, 1553, 1557, 1560	180	30		✓	✓		✓			59	5859
P 30, 300, PKS 65	190	16	✓		✓		✓			65	5865
0051, 1553, 1564, PKS 66, 66CE, 66 A, 66 AF, GKS 65, 65CE	190	30	✓	✓	✓		✓			69	5869
GKS 66, 66CE, 68BC, 68B, P 30	190	30	✓	✓	✓		✓			69	5869
0551, 1561	200	30	✓				✓			74	5874
1554, 1558, 1565, 1588, GKS 75S	210	30	✓	✓	✓		✓			78	5878
0052, 1562, 1566, 0552, 1662, GKS 85 (235mm), 85S	230	30	✓				✓			85	5885
Bench and table saws											
PTS 10, 10T, GTS 10	254	30	✓		✓		✓	✓		93	5893
Chop- and mitre saws											
GCM 8S	216	30								82	5882
GCM 10SD, 10S, 10	254	30	✓							94/93	5894
GCM 12SD, 12, GTM 12	305	30	✓						✓	930	5930
DEWALT											
Circular saws											
DW 62	184	16	✓		✓		✓			61	5861
DW 65	190	30	✓		✓		✓			69	5969
Bench and table saws											
DW 110 *1), DW 111 *1), DW 125 *1), DW 150, DW 744 *1), <small>*1) Red Ring 30 x 16</small>	250	30	✓		✓	✓	✓	✓		93	5893
DW 250, DW 252, DW 320	250	30	✓		✓	✓	✓	✓		93	5893
DW 12 *2), DW 1370, 142 DS, 160 DS, 1635/4L, 3L, <small>*2) Red Ring 30 x 20</small>	300	30	✓			✓	✓	✓		930	5930
1653/3L, 1875, 2155, DW 810	300	30	✓			✓	✓	✓		930	5930
C 14	350	30	✓			✓	✓	✓		935	5935
163546+62, 2155-4+6	400	30				✓	✓	✓		940	5940
1420 S, 1600S, 1635/4L, 1635/6L, 6K, 1875, 2155/4+6	500	30				✓	✓	✓		951	5951
DA 1420S, DA 1600S, DA 1635/54L, DA 1635/6L	500	30				✓	✓	✓		951	5951
Chop- and mitre saws											
DW 110, DW 111, DW 125, DW 150	250	16								95	5895
DW 250, DW 252, DW 320, DW 710	250	30	✓							94/93	5894
DW 810, DW 1370, 1420S, 1600S, 1635/4L, 1875	300	30	✓						✓	930	5930
2155/4, DW 704, DW 705	300	30	✓						✓	930	5930
1420S, 1600S, 1635/4L, 1875, 2155/4	350	30	✓							935	5935
EINHELL											
Circular saws											
HES 160, BT-CS 1200	160	20	✓		✓		✓			45	5845
RT-CS 165 Red-Ring 20 x 16	165	20	✓							48	5848
BT-CS 1400	190	20	✓		✓		✓			67	5867
RT-CS 190L	190	30	✓		✓		✓			69	5969
BT-TS 800	200	16	✓		✓		✓			71	5871
RT-TS 1221	210	30	✓	✓	✓		✓			78	5878

... always the appropriate accessories for your machine!

Manufacturer/ machine model	Blade Ø mm	Bore size Ø mm	Applications							kwb quick reference number	Part-No.
			E	P	M	K	B	C	A		
EINHELL											
Bench and table saws											
BT-TS 1500 U, RT-TS 1825U, RT-TS 1725 U	250	30	✓		✓	✓	✓	✓		93	5893
BT-TS 2031 Z, RT-TS 2031 U, RT-TS 2231 DU	315	30	✓			✓	✓	✓		931	5931
Chop- and mitre saws											
BT-MS 210 T, BT-MS 210, BT-SM 2050, RT-SM 305 L	210	30	✓							78	5878
KGTN 250, KGTN 245, BT-MS 250 T, BT-SM 3100	250	30	✓							94/93	5894
BT-MS 250 L, RT-SM 430 U	250	30	✓							94/93	5894
ELEKTRA-BECKUM											
Circular saws											
PK 200, P 200, UK 200 W, UK 200E	210	30	✓	✓	✓		✓			78	5878
Bench and table saws											
KS 250, KS 304, PK 3100 WN/250, PK 4200 DN/250	250	30	✓		✓	✓	✓	✓		93	5893
PK 6000 DN/250, DN 4200, PK 255 TOP LINE	250	30	✓		✓	✓	✓	✓		93	5893
PKF 255 V8, PKF 255 Profi Line, UK 250 Profi Line	250	30	✓		✓	✓	✓	✓		93	5893
UK 330 Profi Line	250	30	✓		✓	✓	✓	✓		93	5893
1800, 2200, 2800, 3100, 4100, Combi HS 315, TKHS 315	315	30	✓			✓	✓	✓		931	5931
BS 3100 WNB/400, BS 4200 DNB/400, BKS 400	400	30				✓	✓	✓		940	5940
BS 6000 DNB/500	400	30				✓	✓	✓		940	5940
BKH 450, BKS 450, BS 3100 WNB/400, BS 6000/500	450	30				✓	✓	✓		945	5945
BS 4200 DNB/400	450	30				✓	✓	✓		945	5945
BS 8000 D, BS 6000 DNB/500, BS 3100 WNB/400	500	30				✓	✓	✓		951	5951
BS 4200 DNB/400	500	30				✓	✓	✓		951	5951
Chop- and mitre saws											
KGS 250, KGS 300, KGS 330, KGT 500	250	30	✓							94/93	5894
ELU											
Circular saws											
MH 151, MH 151/10	150	20	✓		✓		✓			35	5835
MH 55, MH 155, MH 65	170	30	✓	✓			✓			54	5854
MH 65	180	30			✓		✓			59	5859
MH 165, MH 265	190	30	✓		✓		✓			69	5869
MH 30, MH 82, MH 182, PS 174	210	30	✓		✓		✓			78	5878
Bench and table saws											
KS 101, TGS 170, TGS 171, TGS 172, TGS 173, ETS 21	250	30	✓		✓		✓	✓		93	5893
ETS 23, ETS 31, ETS 33, KSU 101, RKS 1251, RKS 1253	250	30	✓		✓		✓	✓		93	5893
ETS 3001, ETS 3003	300	30	✓				✓	✓		930	5930
DG 102, SA 103, 104, MGS 105, LBK 500	400	30	✓				✓	✓		940	5940
RSA 133/25	500	30	✓				✓	✓		951	5951
Chop- and mitre saws											
TGS 170, TGS 171, TGS 172, TGS 173, TGS 2271	250	30	✓							94/93	5894
TGS 273	250	30	✓							94/93	5894
EMCO											
Bench and table saws											
Super Red-Ring 30 x 20	250	30	✓		✓		✓	✓		93	5893
ERGO TOOLS PATTFIELD											
Circular saws											
E-HKS 1600	190	20	✓							67	5867

Circular saw blades classified by Manufacturer/ machine model

Manufacturer/ machine model	Blade Ø mm	Bore size Ø mm	Applications							kwb quick reference number	Part-No.
			E	P	M	K	B	C	A		
FEIN											
Circular saws											
SSK 646	150	20	✓		✓		✓			35	5835
SSK 660	160	20	✓		✓		✓			45	5845
SSK 661, SSK 661-1	210	30	✓	✓	✓		✓			78	5878
FELISATTI											
Chop- and mitre saws											
T 770, T 771, T 778, T 777, T 777 CE, T 84, T 85, T 87	250	20								96	5896
T 867 GS, T 777 B	250	20								96	5896
M 74, M 75, M 76, M 77, T 84, T 85, T 87, T 88	250	30	✓							94/93	5894
M 79, M 80, M 90, M 90E, T 82, T 92, T 97 CE, T 83	300	30	✓						✓	930	5930
T 91, T 91 CE	300	30	✓						✓	930	5930
FESTO											
Circular saws											
AU 35S2	125	20		✓						13	5813
AP 55, 55E, 55E-FS, 55EB, 55-FS, ATF 55, 55E, 55BE, 55-FS	160	20	✓		✓		✓			45	5845
AM 42S, 42A, AT 55E, 55EB, AU 42A, 42S, AUT 42S	170	30	✓				✓			54	5854
AXT 50LA, 55, AMT 42S	170	30	✓		✓		✓			54	5854
AU 55S, 60P, 60S, AUT 42S, 60S, AUP 605	180	30		✓	✓		✓			59	5859
AP 65E, 65E-FS, 65, 65EB, AP 65EB-FS, AT 65E-FS	190	30	✓		✓		✓			69	5969
AT 65E, 65EB, 65, 65EB-FS	190	30	✓		✓		✓			69	5969
AD 65, AP 65S, 68E, AU 65S, AXP 65, 200, AUP 65S	200	30	✓				✓			74	5874
Au 80S	230	30	✓				✓			85	5885
Bench and table saws											
AD 85, AD 100, AD 100/1, AE 85	250	30	✓		✓	✓	✓	✓		93	5893
AXP 130, AXP 132E, BD 125	350	30	✓			✓	✓	✓		935	5935
BD 145, BD 145/1	400	30				✓	✓	✓		940	5940
BD 170	450	30				✓	✓	✓		945	5945
FERM											
Circular saws											
CSM 1002	165	20	✓							48	5848
CSM 1022	185	20	✓		✓		✓			57	5857
TSM 1008	200	16	✓		✓		✓			71	5871
MSM 1020, MSM 1007, MSM 1030 Red-Ring 30 x 16	210	30	✓	✓	✓		✓			78	5878
Bench and table saws											
TSM 1011 Red-Ring 30 x 16	250	30	✓		✓	✓	✓	✓		93	5893
Chop- and mitre saws											
MSM 1020 *1), MSM 1007 *1), MSM 1030 *1) *1) Red.-Ring 30 x 16	210	30	✓							78	5878
FLOTT											
Bench and table saws											
Basic-Uni-Kombi 1011, Uni-Profi 2011, Profi 3011	250	30	✓		✓	✓	✓	✓		93	5893
Basic-Uni-Kombi, KS 2011D, KS 2011W, TKS 2011D	250	30	✓		✓	✓	✓	✓		93	5893
TKS 2011W	250	30	✓		✓	✓	✓	✓		93	5893
100000, 2000 Red-Ring 30 x 20	300	30	✓			✓	✓	✓		930	5930
Profi 2001 Red-Ring 30 x 20	315	30	✓			✓	✓	✓		931	5931

... always the appropriate accessories for your machine!

Manufacturer/ machine model	Blade Ø mm	Bore size Ø mm	Applications							kwb quick reference number	Part-No.
			E	P	M	K	B	C	A		
HAFFNER											
Circular saws											
KSU 105, KSU 125	125	20		✓						13	5813
KSU 50	160	20	✓		✓		✓			45	5845
KSU 110	170	30	✓				✓			54	5854
KSU 113, KSU 60	180	30		✓	✓		✓			59	5859
GL 136	200	16	✓		✓		✓			71	5871
AKS	200	30	✓				✓			74	5874
KS 75, KSU 118, RS 75	210	30	✓	✓	✓		✓			78	5878
HSU 85, KS 85, KSU 85	230	30	✓				✓			85	5885
SP 187, HUS 85	230	30	✓				✓			85	5885
Bench and table saws											
AKS, GS 150, GS 165, GS 166, SP 189, 20, SP 195	250	30	✓		✓	✓	✓	✓		93	5893
SP 196, SP 197, SP 198, TGS 161, KL 140, TGS 162	250	30	✓		✓	✓	✓	✓		93	5893
TGS 163, TGS/GS 1+2	250	30	✓		✓	✓	✓	✓		93	5893
GS 155, GS 156, GS 157, GS 158, SP 221, SP 223	300	30	✓			✓	✓	✓		930	5930
SP 224, TGS 168, TGS 169, US 151, GS 148, GS 165	300	30	✓			✓	✓	✓		930	5930
GS 166, 950, TGS 200	300	30	✓			✓	✓	✓		930	5930
KS 120	315	30	✓			✓	✓	✓		931	5931
DGS 184, DGS 184 E, GS 183, GS 183M, KS 155	400	30				✓	✓	✓		940	5940
DGS 188, DGS 188 M, ZS 640, ZS 800, DGS 180, 182	400	30				✓	✓	✓		940	5940
185, GSA 184 (E), KS 155	400	30				✓	✓	✓		940	5940
DGS 124, DGS 187, GS 124, US 161, DGS 202, GS 161	500	30				✓	✓	✓		951	5951
GS 162	500	30				✓	✓	✓		951	5951
Chop- and mitre saws											
GS 150	250	30	✓							94/93	5894
GS 146, GS 147, GFS 200, GS 157, GS 158	300	30	✓						✓	930	5930
GS 159, GS 160, ZS 800	350	30	✓							935	5935
HANNING											
Circular saws											
TK 20N, 20S, 200, 300	200	16	✓		✓		✓			71	5871
Bench and table saws											
HKS 250 Red-Ring 30 x16	250	30	✓		✓	✓	✓	✓		93	5893
HTK 315/3SV	315	30	✓			✓	✓	✓		931	5931
HITACHI											
Circular saws											
C 5Y	125	20		✓						13	5813
C 5, CM 6, FC 5, 5SA, 5SA1	150	20	✓		✓		✓			35	5835
C 6DA, FC 6SA, 65A, C 6, D 1	160	20	✓		✓		✓			45	5845
C 6SA, PSU-6	170	30	✓				✓			54	5854
C 18DL, C 6MFA, C 6BU2, C 6BU2K	165	30	✓				✓			54	5854
C 8U	180	30		✓	✓		✓			59	5859
FC 7SA, PSM-7, 7A, PSU-7, C 7MFA, C 7BU2	190	30	✓		✓		✓			69	5969
C 8FA, C 8U, PSM-8, 8A, PSU-8	210	30	✓	✓	✓		✓			78	5878
C 9U, C 9U2 (235)	230	30	✓				✓			85	5885
Bench and table saws											
PSU 13	315	30	✓			✓	✓	✓		931	5931
Chop- and mitre saws											
C 10FSH (255)	255	30	✓							94/93	5894
C 12LSH (305)	305	30	✓						✓	930	5930

Circular saw blades classified by Manufacturer/ machine model

Manufacturer/ machine model	Blade Ø mm	Bore size Ø mm	Applications							kwb quick reference number	Part-No.
			E	P	M	K	B	C	A		
HOLZ-HER											
Circular saws											
264, 1420, 2103, 2104, 2105, 2106, HKU 50, 264, HKUS 50	160	20	✓		✓		✓			45	5845
281, 2115(T55a), 2266, 2271, 2281, HKUS 266, 281, 55 A	170	30	✓				✓			54	5854
2112, 2269, 2282, 2113, 2292, 2272, 2291, HKU 2272, 2291	180	30		✓	✓		✓			59	5859
HKUS 269, 272, 282, 55	180	30		✓	✓		✓			59	5859
211, 2114, 2116(T65a), 2117(T65), 2119(T65e), 2126, 2127	190	30	✓		✓		✓			69	5969
2269, 2282, 2292, 2116, 2117, 2119, HK 282	190	30	✓	✓	✓		✓			69	5969
2113, 2292, 2555, HK 201	200	30	✓				✓			74	5874
2264, 2267, 2279, 2284, PKS 267, 284	210	30	✓	✓	✓		✓			78	5878
2118(T85), 2120(T85e), 2279, 2293, 2294, 2118, 2120	230	30	✓				✓			85	5885
Bench and table saws											
HKD 85, 275, PKS 1210, 1211, 1212, 1213, 1215, 1220	300	30	✓			✓	✓	✓		930	5930
PKS 275, HKD 275	300	30	✓			✓	✓	✓		930	5930
HKS 130, 150, 176, 276	350	30	✓			✓	✓	✓		935	5935
B 7K, HKS 155, 277	400	30				✓	✓	✓		940	5940
INCA											
Bench and table saws											
MajOR Red-Ring 30 x 20	250	30	✓		✓		✓	✓		93	5893
KRESS											
Circular saws											
1050KS, 6050, 6055 Duo, CHKS 6055, 6050	160	20	✓		✓		✓			45	5845
6055a, Elekt.-Duo-Säge	160	20	✓	✓	✓		✓			45	5845
1400KS, 1600KS, 1500KS, 1600HTKS, 6060, 6060 B	190	20	✓		✓		✓			67	5867
CHKS 6060, 6006, 6066, 1800 KSE	190	20	✓		✓		✓			67	5867
Chop- and mitre saws											
GST 90	250	30	✓							94/93	5894
LESCHA											
Bench and table saws											
TKS 315 H, TKS 315 HS, TKS 315 N	315	30	✓			✓	✓	✓		931	5931
LUTZ											
Bench and table saws											
Jumbo 2000, KKS 400, KKS Starr, RBK 500, Eurocut	315	30	✓			✓	✓	✓		931	5931
Jumbo	315	30	✓			✓	✓	✓		931	5931
LBK 500 Starr, LBK 500	400	30				✓	✓	✓		940	5940
RKS 700	450	30				✓	✓	✓		945	5945
LBK Starr, RKS 700	500	30				✓	✓	✓		951	5951
LUX TOOLS											
Circular saws											
Lux Tools	190	30	✓		✓		✓			69	5869
MAFELL											
Circular saws											
X 40, XE 40, SF 32	125	20		✓						13	5813
Biberella	150	13		✓						31	5831
MKS 55, MS 55, PS 52, A 55, X 55, XE 55, KSP 55(F)	160	20	✓		✓		✓			45	5845
KSS 330, FU 50	160	20	✓	✓	✓		✓			45	5845
A 55, B 55, FU 50, FU 550, FUS 50, FK 50	170	20		✓						51	5851

Manufacturer/ machine model	Blade Ø mm	Bore size Ø mm	Applications							kwb quick reference number	Part-No.
			E	P	M	K	B	C	A		
MAFELL											
Circular saws											
ERIKA 55	180	30		✓	✓		✓			59	5859
MKS 65, MS 65, ERIKA 60, KSP 65(F)	190	30	✓		✓		✓			69	5969
B 65, X 72	200	30	✓				✓			74	5874
MKS 75, MKS 85S, MS 75	210	30	✓	✓	✓		✓			78	5878
KSP 85 F	230	30	✓				✓			85	5885
Bench and table saws											
A 85, FS 65, Fus 85, MKS 85, MS 85, ERIKA, MKS 85 N	250	30	✓		✓	✓	✓	✓		93	5893
MKS 85 S, ERIKA 85, FKS 65	250	30	✓		✓	✓	✓	✓		93	5893
FS 85, MKS 105, Biber, Biberex, MKS 105 E, MONIKA	315	30	✓			✓	✓	✓		931	5931
TFK 8G, TFK 8	315	30	✓			✓	✓	✓		931	5931
MKS 125, BSK 4, BSK 5, BSK 6, SF 32	350	30	✓			✓	✓	✓		935	5935
AZB, BK 3, FKB 150, TDH 4, TDH 425, TK 150, VKS 130	400	30				✓	✓	✓		940	5940
VKS 160, FS 130 S, TD 3, BSK 4, BSK 5, BSK 6	400	30				✓	✓	✓		940	5940
BK, BKV 4, FSG 165, TDH 450, TDH 5, BK 4, BSK 5	450	30				✓	✓	✓		945	5945
BSK 6, FSG 165K, MKS 185E, FSG 200K-240	450	30				✓	✓	✓		945	5945
BKV 5, FSG 2000, TDH 5/170, FSK 2000	500	30				✓	✓	✓		951	5951
MAKITA											
Circular saws											
5600NB, 5603R, 5600RDW, SR 1600	160	20	✓		✓		✓			45	5845
SR 1600	165	20	✓							48	5848
5600BR	170	20		✓						51	5851
5800, 5800B, 5800N, 5801B, S 800BR, SR 1800, 5500 S	180	20	✓		✓		✓			57	5857
3501, 5800BR	190	20	✓		✓		✓			67	5867
5703 R	190	30	✓		✓		✓			69	5869
5700	200	30	✓				✓			74	5874
5903 R	230	30	✓				✓			85	5885
Bench and table saws											
2400 *1), SR 2402 *1), SR 2600 *1) *1) Red-Ring 30 x 25	250	30	✓		✓	✓	✓	✓		93	5893
5100 BR	315	30	✓			✓	✓	✓		931	5931
LS 1400 *1), 5143 R *1) Red-Ring 30 x 25	350	30	✓			✓	✓	✓		935	5935
Chop- and mitre saws											
LS 1030 *1), LS 0813 *1) *1) Red-Ring 30 x 25	250	30	✓							94/93	5894
METABO											
Circular saws											
BHK 01, 2, KS 3340S, 3342, 4340, 6311, Max KS 40S	130	16			✓		✓			18	5818
KS 4342S	130	16			✓		✓			18	5818
BHK 2+3, 4340S	142	13		✓	✓		✓			29	5829
BTK 1, C 2, KS 1155S	165	20	✓							48	5848
6317S	180	20	✓		✓		✓			57	5857
BTK, KS 65S, KS 4345S, KS 4346S, KSE 1668S, Robert	190	20	✓		✓		✓			67	5867
TK 5348, KS 1266S, KS 1468S, 46 S, 5348, KS 166S	190	20	✓		✓		✓			67	5867
KS 1266, KS 4345S	190	20	✓		✓		✓			67	5867
KSE 1678S Signal, MAGNUM KGS E 1670S-SIGNAL	210	30	✓	✓	✓		✓			78	5878
Bench and table saws											
Magnum TKU 1693, Magnum TK 1685, TKU 1633	250	30	✓		✓	✓	✓	✓		93	5893
TKU 1693, TK 1685	250	30	✓		✓	✓	✓	✓		93	5893
TK 1688(D)	300	30	✓			✓	✓	✓		930	5930
TK 168S, TK 1685D, TK 1685, TK 16850	315	30	✓			✓	✓	✓		931	5931

Circular saw blades classified by Manufacturer/ machine model

Manufacturer/ machine model	Blade Ø mm	Bore size Ø mm	Applications							kwb quick reference number	Part-No.
METABO			E	P	M	K	B	C	A		
Chop- and mitre saws											
KGS E 1670 S, KGS E 16705 SIGNAL	210	30	✓		✓				✓	78	5878
KGS 16-300 (PLUS)	250	30	✓		✓				✓	94/93	5894
MAC ALLISTER			E	P	M	K	B	C	A		
Circular saws											
MCS 1200 L	165	16				✓				7	5807
MCS 1400 L	190	16	✓		✓		✓			65	5865
Chop- and mitre saws											
MSMS255DBL	254	30	✓		✓					93	5893
MILWAUKEE			E	P	M	K	B	C	A		
Chop- and mitre saws											
6494-50, 6496-50	250	30	✓							94/93	5894
NIKO			E	P	M	K	B	C	A		
Bench and table saws											
TS 10 (254mm)	250	30	✓		✓	✓	✓	✓		93	5893
Chop- and mitre saws											
MS 305 (254)	254	30	✓							94/93	5894
DC 14 (355x25,4)	355	25.4	✓							935	5935
PARKSIDE			E	P	M	K	B	C	A		
Circular saws											
PHKS 66	190	30	✓		✓		✓			69	5869
PERLES			E	P	M	K	B	C	A		
Circular saws											
KS 50	152	20	✓		✓		✓			35	5835
PEUGEOT			E	P	M	K	B	C	A		
Circular saws											
SC 46, 52, 52C, 53C	150	20	✓		✓		✓			35	5835
SC 4510XA	160	16	✓		✓		✓			43	5843
FIP 20S, FIP 50S	180	20	✓		✓		✓			57	5857
10XA, SC 65C, 650, 66C, SC 65010xA	184	16	✓		✓		✓			61	5861
ROCKWELL			E	P	M	K	B	C	A		
Circular saws											
63416	160	16	✓		✓		✓			43	5843
RYOBI			E	P	M	K	B	C	A		
Circular saws											
W-5502, W-560, W-560P	160	20	✓		✓		✓			45	5845
W-651, W-6502, W-66N, W-651A	180	20	✓		✓		✓			57	5857
W-6403NC, W-640NCI, W-6403C	184	16	✓		✓		✓			61	5861
W-750	200	16	✓		✓		✓			71	5871
SCHEER			E	P	M	K	B	C	A		
Circular saws											
MS 50	150	16	✓		✓		✓			33	5833
MS 45, MS 45E, MS 45/3, 45E	150	20	✓		✓		✓			35	5835
FM	160	16	✓		✓		✓			43	5843

... always the appropriate accessories for your machine!

Manufacturer/ machine model	Blade Ø mm	Bore size Ø mm	Applications							kwb quick reference number	Part-No.
			E	P	M	K	B	C	A		
SCHEER											
Circular saws											
MS 55	165	20	✓							48	5848
MS 65	190	30	✓		✓		✓			69	5969
MS 70, FM 16DNC, FM 16 Elektronic, FM 16 Standard	200	30	✓				✓			74	5874
MS 85	230	30	✓				✓			85	5885
SCHEPPACH											
Bench and table saws											
TKG 250, TKS 250, KSE 250	250	30	✓		✓	✓	✓	✓		93	5893
TK 1685 Magnum, TKH, TKU, TS 4000, TS 4010	300	30	✓			✓	✓	✓		930	5930
TK, TKH, TKU, ts 4000, ts 4010, FORSATO XL, TG 315	315	30	✓			✓	✓	✓		931	5931
FORSATO XXL	315	30	✓			✓	✓	✓		931	5931
BSH 400, BSH 500	400	30				✓	✓	✓		940	5940
BS 500, BSH 500, WS 500	450	30				✓	✓	✓		945	5945
BS 500, BSH 500, WS 500	500	30				✓	✓	✓		951	5951
KE 6, KE 6M, KE 60, KE 60M, KE 6011, KE 611, KH 6	600	30				✓		✓		960	5960
KH 60, KW 60, KW 60M, KW 601, KW 6011, KW 611	600	30				✓		✓		960	5960
KDZ 700, KE 70, KW 70, KWZ 700, KH 70, KW 7, KWZ 7	700	30				✓		✓		970	5970
KD 2700, KE 7011, KEZ 700, KW 2700	700	30				✓		✓		970	5970
SCHLEICHER											
Bench and table saws											
310, 330	300	30	✓			✓	✓	✓		930	5930
Chop- and mitre saws											
6	300	30	✓						✓	930	5930
07, 08	350	30	✓							935	5935
SKIL											
Circular saws											
5240H, 5140	130	16			✓		✓			18	5818
533, 553	150	13		✓						31	5831
1850H, 1850	150	20	✓		✓		✓			35	5835
367, 416H, 534, 536, 552B, 552H, 856, 1408H, 1409H	160	16	✓		✓		✓			43	5843
1410H, 1855U, 1854, 1855H, 1865	160	16	✓		✓		✓			43	5843
22501B	170	30	✓	✓			✓			54	5854
1865, 537, 553B, 553H, 559, 559U, 574U, 77, 77U, 857	184	16	✓		✓		✓			61	5861
1850, 1865, 599U	184	16	✓		✓		✓			61	5861
1865H, 1965U, 1865U, 5565, 5666, 5566, 5266, 554B	190	16	✓		✓		✓			65	5865
554H, 8244, 825, 858	190	16	✓		✓		✓			65	5865
1965U	190	30	✓		✓		✓			69	5869
1524H, 1873H	210	30	✓	✓			✓			78	5878
1525H, 1886H, 1986, 1985U	230	30	✓				✓			85	5885
Bench and table saws											
107 *1), 860 *1), 1526H, 1899H, *1) Red-Ring 30 x 16	250	30	✓		✓	✓	✓	✓		93	5893
127, 2127	300	30	✓			✓	✓	✓		930	5930
STAYER											
Circular saws											
CP 66, CP 66E	190	30	✓		✓		✓			69	5869
CP 76	210	30	✓	✓			✓			78	5878
CP 86	230	30	✓				✓			85	5885

Circular saw blades classified by Manufacturer/ machine model

Manufacturer/ machine model	Blade Ø mm	Bore size Ø mm	Applications							kwb quick reference number	Part-No.
			E	P	M	K	B	C	A		
STAYER											
Chop- and mitre saws											
SLL 250, SCE 1600, SC 270, SC 271, SLL 251	250	30	✓							94/93	5894
SLL 251 E, SL 251 E, SL 250 E	250	30	✓							94/93	5894
STRIEBIG											
Bench and table saws											
Plattensäge	300	30	✓			✓	✓	✓		930	5930
TOOLTEC											
Circular saws											
TOOLTEC Handkreissäge	185	20	✓		✓		✓			57	5857
Bench and table saws											
TOOLTEC Bau- und Tisch-Kreissäge	200	30	✓				✓			74	5874
ULMIA											
Circular saws											
1610, 1607	160	16	✓		✓		✓			43	5843
1607, 1708	200	16	✓	✓	✓		✓			71	5871
1706	200	30	✓				✓			74	5874
Bench and table saws											
1622, 1625, 1710, 1610, 1710R, 1710SN, 1711, KS 1	250	30	✓		✓	✓	✓	✓		93	5893
1711, 1712, 1725	300	30	✓			✓	✓	✓		930	5930
KS 300	315	30	✓			✓	✓	✓		931	5931
1712, 1725, 1728, 1729, 1711, 1712RT, 1712/1712R	350	30	✓			✓	✓	✓		935	5935
Chop- and mitre saws											
1728	350	30	✓							935	5935
WEGOMA											
Bench and table saws											
TS 400	400	30				✓	✓	✓		940	5940
SD 25, SD 30	500	30				✓	✓	✓		951	5951
Chop- and mitre saws											
RS 460	250	30	✓							94/93	5894
RS 660	300	30	✓						✓	930	5930
SD 16, S 40, S 4W, SD 17AE, SD 17 M+P	350	30	✓							935	5935
WOLF											
Circular saws											
6070	184	16	✓		✓		✓			61	5861
WORX DIY											
Circular saws											
WX425	160	25			✓		✓			46	5846
WX431K	185	30		✓	✓		✓			59	5859
WX441, WX445, 1500W Blade Runner	190	30	✓		✓		✓			69	5869
WORX PRO											
Circular saws											
WU530	165	30	✓							48	5848
WT431KE	185	30		✓	✓		✓			59	5859
WU 430.1, WU434/WU434.1	190	30	✓		✓		✓			69	5869

EASY CUT multi material blade



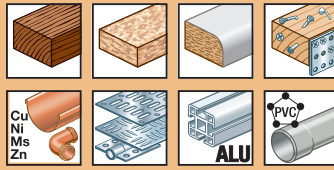



















- tungsten carbide tipped
- special variable toothing
- zero hook
- suitable for all types of saw
- precise, clean cut



- Boards
- Laminated boards
- Construction timber
- Light alloy
- Thin sheet steel
- Aluminium profiles
- Plastics including Plexiglas

E

Circular saw blades for hand held circular saws Ø 150 up to Ø 230 mm

Manufacturer	kwb Code	Part-No.	Ø x  mm	Teeth	 mm	 mm			Barcode	Quality
Bosch Scheer	E 33	583333	150 x 16	24	2,8	1,8		1		★★★★★
AEG B & D ELU Fein Hitachi Metabo Perles Peugeot Scheer Skil	E 35	583533	150 x 20	24	2,8	1,8		1		★★★★★
B & D	E 41	584133	156 x 12,75	24	2,8	1,8		1		★★★★★
B & D Bosch Peugeot Rockwell Scheer Skil Ulmia	E 43	584333	160 x 16	24	2,8	1,8		1		★★★★★
AEG Bosch Einhell Fein Festo Haffner Hitachi Holz-Her Kress Mafell Makita Ryobi	E 45	584533	160 x 20	24	2,8	1,8		1		★★★★★
Einhell Ferm Makita Metabo Scheer Worx Diy Worx Pro	E 48	584833	165 x 20	24	2,8	1,8		1		★★★★★
Bosch ELU Festo Haffner Hitachi Holz-Her Skil	E 54	585433	170 x 30	24	2,8	1,8		1		★★★★★
B & D Ergo Tools Pattfield Ferm Makita, Metabo Peugeot Ryobi Skil Tooltec	E 57	585733	180 x 20	30	2,8	1,8		1		★★★★★
B & D DeWalt Peugeot Ryobi Skil Wolf	E 61	586133	184 x 16	30	2,8	1,8		1		★★★★★

Circular saw blades for hand held circular saws

EASY CUT multi material blade



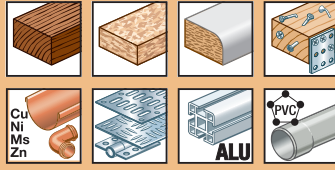















- tungsten carbide tipped
- special variable toothing
- zero hook
- suitable for all types of saw
- precise, clean cut



- Boards
- Laminated boards
- Construction timber
- Light alloy
- Thin sheet steel
- Aluminium profiles
- Plastics including Plexiglas

E

Circular saw blades for hand held circular saws Ø 150 up to Ø 230 mm

Manufacturer	kwb Code	Part-No.	Ø x  mm	Teeth	 mm	 mm			Barcode	Quality
Bosch Mac Allister Skil	E 65	586533	190 x 16	30	2,8	1,8		1		★★★★★
Einhell Kress Makita Metabo	E 67	586733	190 x 20	30	2,8	1,8		1		★★★★★
AEG Bosch DeWalt Einhell ELU Festo Hitachi Holz-Her Lux Tools Mafell Makita Parkside Scheer Skil Stayer Worx Diy, Worx Pro	E 69	586933	190 x 30	30	2,8	1,8		1		★★★★★
B & D Einhell Ferm Haffner Hanning Ryobi Ulmia	E 71	587133	200 x 16	30	2,8	1,8		1		★★★★★
AEG Bosch Festo Haffner Holz-Her Mafell, Makita Scheer Tooltec Ulmia	E 74	587433	200 x 30	30	2,8	1,8		1		★★★★★
AEG Alpha Tools B & D, Bosch Einhell Elektra-Beckum ELU Fein, Ferm Haffner Hitachi Holz-Her Mafell, Metabo Skil, Stayer	E 78	587833	210 x 30	34	2,8	1,8		1		★★★★★
AEG B & D, Bosch Festo Haffner Hitachi Holz-Her Mafell Makita Scheer Skil Stayer	E 85	588533	230 x 30	34	2,8	1,8		1		★★★★★

Fine cut blade



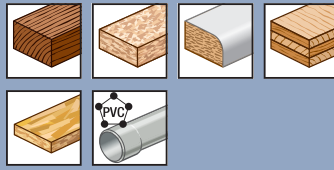

- Tungsten carbide tipped
- Fine teeth
- Positive hook
- For hand held- bench- and table saws
- Quick, fine cut
- Splinter-free cutting edges



- Solid wood
- Laminated boards (work surfaces and kitchen worktops)
- Blockboard, chipboard, fibreboard
- Glass-fibre reinforced plastics

P

Circular saw blades for hand held circular saws Ø 125 up to Ø 230 mm

Manufacturer	kwb Code	Part-No.	Ø x  mm	Teeth	 mm	 mm			Barcode	Quality
AEG Festo Haffner Hitachi Mafell	P 13	581366	125 x 20	36	2,5	1,5		1	 4 009315 813660	★★★★★
B & D	P 23	582366	140 x 12,75	42	2,5	1,5		1	 4 009315 823669	★★★★★
Metabo	P 29	582966	142 x 13	42	2,5	1,5		1	 4 009315 829661	★★★★★
Kress Mafell Skil	P 31	583166	150 x 13	48	2,8	1,8		1	 4 009315 831664	★★★★★
AEG B & D ELU Fein Hitachi Metabo Perles, Peugeot Scheer, Skil	P 35	583566	150 x 20	48	2,8	1,8		1	 4 009315 835662	★★★★★
Mafell Makita	P 51	585166	170 x 20	52	2,8	1,8		1	 4 009315 851662	★★★★★
Bosch ELU Fern, Festo Haffner Hitachi Holz-Her Mafell Worx Diy, Worx Pro	P 59	585966	180 x 30	56	2,8	1,8		1	 4 009315 859668	★★★★★
AEG Bosch Festo Haffner Holz-Her Mafell, Makita Scheer Tooltec Ulmia	P 74	587466	200 x 30	64	2,8	1,8		1	 4 009315 874661	★★★★★
AEG Alpha Tools B & D, Bosch Einhell Elektra-Beckum ELU Fern, Fein Haffner Hitachi Holz-Her Mafell, Metabo Skil, Stayer	P 78	587866	210 x 30	64	2,8	1,8		1	 4 009315 878669	★★★★★
AEG B & D, Bosch Festo Haffner Hitachi Holz-Her Mafell, Makita Scheer Skil Stayer	P 85	588566	230 x 30	64	3,2	2,2		1	 4 009315 885667	★★★★★

Circular saw blades for hand held circular saws

Chipboard blade

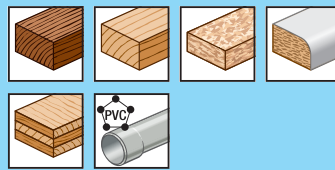

- Tungsten carbide tipped
- Regular teeth
- Positive hook
- for hand held circular saws
- Quick, clean cut



- Solid wood
- Laminated boards (work surfaces and kitchen worktops)
- Blockboard, chipboard, fibreboard
- Glass-fibre reinforced plastics

M

Circular saw blades for hand held circular saws Ø 127 up to Ø 230 mm

Manufacturer	kwb Code	Part-No.	Ø x  mm	Teeth	 mm	 mm			Barcode	Quality
B & D	M 15	581555	127 x 12,75	18	2,4	1,4		1		★★★★★
Bosch Metabo Skil	M 18	581855	130 x 16	18	2,4	1,4		1		★★★★★
B & D	M 23	582355	140 x 12,75	18	2,4	1,4		1		★★★★★
AEG Bosch Holz-Her Metabo Peugeot Stayer	M 28	582855	140 x 20	18	2,4	1,4		1		★★★★★
Metabo	M 29	582955	142 x 13	18	2,4	1,4		1		★★★★★
Bosch Scheer	M 33	583355	150 x 16	20	2,4	1,4		1		★★★★★
AEG B & D ELU Fein Hitachi Metabo Perles Peugeot Scheer, Skil	M 35	583555	150 x 20	20	2,4	1,4		1		★★★★★
B & D Bosch Peugeot Rockwell Scheer, Skil Ulmia	M 43	584355	160 x 16	20	2,4	1,4		1		★★★★★
AEG Bosch Einhell Fein Festo Haffner Hitachi Holz-Her Kress Mafell, Makita Ryobi	M 45	584555	160 x 20	20	2,4	1,4		1		★★★★★
Fabrikate alte DDR	M 46	584655	160 x 25	20	2,4	1,4		1		★★★★★
B & D Ferm Makita Metabo Peugeot Ryobi Skil Tooltec	M57	585755	180 x 20	22	2,4	1,4		1		★★★★★
Bosch ELU Festo Haffner Hitachi Holz-Her Mafell Worx Diy, Worx Pro	M 59	585955	180 x 30	22	2,4	1,4		1		★★★★★

Chipboard blade



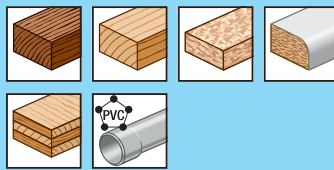















- Tungsten carbide tipped
- Regular teeth
- Positive hook
- for hand held circular saws
- Quick, clean cut



- Solid wood
- Laminated boards (work surfaces and kitchen worktops)
- Blockboard, chipboard, fibreboard
- Glass-fibre reinforced plastics

M

Circular saw blades for hand held circular saws Ø 125 up to Ø 230 mm

Manufacturer	kwb Code	Part-No.	Ø x  mm	Teeth	 mm	 mm			Barcode	Quality
B & D DeWalt Peugeot Ryobi Skil Wolf	M 61	586155	184 x 16	22	2,4	1,4		1		★★★★★
Bosch Mac Allister Skil	M 65	586555	190 x 16	30	2,4	1,4		1		★★★★★
Einhell Kress Makita Metabo	M 67	586755	190 x 20	30	2,4	1,4		1		★★★★★
AEG B & D Bosch DeWalt Einhell ELU Festo Hitachi Holz-Her Lux Tools Mafell Makita Parkside Scheer Skil Stayer Worx Diy Worx Pro	M 69	586955	190 x 30	30	2,4	1,4		1		★★★★★
B & D Einhell Ferm Haffner Hanning Ryobi Ulmia	M 71	587155	200 x 16	30	2,4	1,6		1		★★★★★
Fabrikate alte DDR	M 73	587355	200 x 25	30	2,6	1,6		1		★★★★★
AEG Alpha Tools B & D Bosch Einhell Elektra-Beckum ELU Fein Ferm Haffner Hitachi Holz-Her Mafell Metabo Skil Stayer	M 78	587855	210 x 30	30	2,4	1,6		1		★★★★★

Circular saw blades for hand held circular saws

Moulding blade



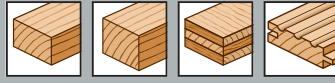













- Chrome vanadium
- Pointed teeth
- Positive hook
- for hand-held, bench and table saws
- Fine, precise cut



- Softwood
- Plywood
- Panels
- Mouldings

B

Circular saw blades for hand held circular saws Ø 127 up to Ø 230 mm

Manufacturer	kwb Code	Part-No.	Ø x  mm	Teeth	 mm	 mm		Barcode	Quality
B & D	B 15	581511	127 x 12,75	80	2,2	1,2		4 009315 815114	★★★★★
Bosch Metabo Skil	B 18	581811	130 x 16	64	2,2	1,2		4 009315 818115	★★★★★
B & D	B 23	582311	140 x 12,75	80	2,2	1,2		4 009315 823119	★★★★★
AEG Bosch Holz-Her Metabo Peugeot Stayer	B 28	582811	140 x 20	90	2,2	1,2		4 009315 828114	★★★★★
Metabo	B 29	582911	142 x 13	80	2,2	1,2		4 009315 829111	★★★★★
Bosch Scheer	B 33	583311	150 x 16	64	2,2	1,2		4 009315 833118	★★★★★
AEG B & D ELU Fein Hitachi Metabo Perles Peugeot Scheer Skil	B 35	583511	150 x 20	90	2,2	1,2		4 009315 835112	★★★★★
B & D	B 41	584111	156 x 12,75	80	2,2	1,2		4 009315 841113	★★★★★
B & D Bosch Peugeot Rockwell Scheer Skil Ulmia	B 43	584311	160 x 16	110	2,2	1,2		4 009315 843117	★★★★★
AEG Bosch Einhell Fein Festo Haffner Hitachi Holz-Her Kress Mafell Makita Ryobi	B 45	584511	160 x 20	110	2,2	1,2		4 009315 845111	★★★★★
Fabrikate alte DDR	B 46	584611	160 x 25	110	2,2	1,2		4 009315 846118	★★★★★
Bosch ELU Festo Haffner Hitachi Holz-Her Skil	B 54	585411	170 x 30	56	2,4	1,4		4 009315 841113	★★★★★

Moulding blade



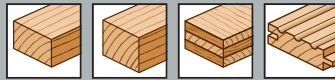

















- Chrome vanadium
- Pointed teeth
- Positive hook
- for hand-held, bench and table saws
- Fine, precise cut



- Softwood
- Plywood
- Panels
- Mouldings

B

Circular saw blades for hand held circular saws Ø 127 up to Ø 230 mm

Manufacturer	kwb Code	Part-No.	Ø x  mm	Teeth	 mm	 mm			Barcode	Quality
B & D Ferm Makita Metabo Peugeot Ryobi Tooltec	B 57	585711	180 x 20	72	2,4	1,4		1	 4 009315 857114	★★★★★
Bosch ELU Festo Haffner Holz-Her Hitachi Mafell Worx Diy Worx Pro	B 59	585911	180 x 30	72	2,4	1,4		1	 4 009315 859118	★★★★★
B & D DeWalt Einhell Peugeot Ryobi Skil Wolf	B 61	586111	184 x 16	100	2,4	1,4		1	 4 009315 861111	★★★★★
Bosch Mac Allister Skil	B 65	586511	190 x 16	110	2,4	1,4		1	 4 009315 865119	★★★★★
Einhell Kress Makita Metabo	B 67	586711	190 x 20	110	2,4	1,4		1	 4 009315 867113	★★★★★
AEG B & D Bosch DeWalt Einhell ELU Festo Hitachi Holz-Her Lux Tools Mafell Makita Parkside Scheer Skil Stayer Worx Diy Worx Pro	B 69	586911	190 x 30	72	2,4	1,4		1	 4 009315 869117	★★★★★
B & D Einhell Ferm Haffner Hanning Ryobi Ulmia	B 71	587111	200 x 16	72	2,6	1,6		1	 4 009315 871110	★★★★★
Fabrikate alte DDR	B 73	587311	200 x 25	72	2,6	1,6		1	 4 009315 873114	★★★★★

Circular saw blades for hand held circular saws

Moulding blade



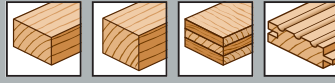







- Chrome vanadium
- Pointed teeth
- Positive hook
- for hand-held, bench and table saws
- Fine, precise cut



- Softwood
- Plywood
- Panels
- Mouldings

B

Circular saw blades for hand held circular saws Ø 127 up to Ø 230 mm

Manufacturer	kwb Code	Part-No.	Ø x  mm	Teeth	 mm	 mm			Barcode	Quality
AEG Bosch Festo Haffner Holz-Her Mafell Makita Scheer Tooltec Ulmia	B 74	587411	200 x 30	72	2,6	1,6		1	 4 009315 874111	★★★★★
AEG Alpha Tools B & D Bosch Einhell Elektra-Beckum ELU Fein Ferm Haffner Hitachi Holz-Her Mafell Metabo Skil Stayer	B 78	587811	210 x 30	72	2,6	1,6		1	 4 009315 878119	★★★★★
AEG B & D Bosch Festo Haffner Hitachi Holz-Her Mafell Makita Scheer Skil Stayer	B 85	588511	230 x 30	72	2,6	1,6		1	 4 009315 885117	★★★★★

EASY CUT multi material blade



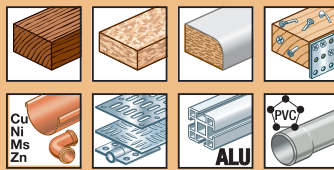









- tungsten carbide tipped
- special variable toothing
- zero hook
- suitable for all types of saw
- precise, clean cut



- Boards
- Laminated boards
- Construction timber
- Light alloy
- Thin sheet steel
- Aluminium profiles
- Plastics including Plexiglas

E

Circular saw blades for bench- and table saws Ø 250 up to Ø 350 mm

Manufacturer	kwb Code	Part-No.	Ø x  mm	Teeth	 mm	 mm			Barcode	Quality
AEG B & D Einhell DeWalt Elektra-Beckum ELU Emco Ferm Festo Flott Haffner Hanning Inca Mafell Makita Metabo Niko Scheppach Skil Ulmia	E 93	589333	250 x 30	42	3	2		1	 4 009315 893334	★★★★★
DeWalt ELU Flott Haffner Holz-Her Metabo Scheppach Schleicher Skil Striebig Ulmia	E 930	593033	300 x 30	48	3,2	2,2		1	 4 009315 930336	★★★★★
AL-KO Atika Einhell Elektra-Beckum Flott Haffner Hanning Hitachi Lescha Lutz Mafell Makita Metabo Scheppach Ulmia	E 931	593133	315 x 30	48	3,2	2,2		1	 4 009315 931333	★★★★★
DeWalt Festo Holz-Her Mafell Makita Ulmia	E 935	593533	350 x 30	54	3,2	2,2		1	 4 009315 935331	★★★★★

Circular saw blades for bench- and table saws

Chipboard blade



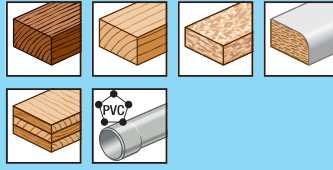



- Tungsten carbide tipped
- Regular teeth
- Positive hook
- for hand held circular saws
- Quick, clean cut



- Solid wood
- Laminated boards (work surfaces and kitchen worktops)
- Blockboard, chipboard, fibreboard
- Glass-fibre reinforced plastics

M

Circular saw blades for bench- and table saws Ø 250 mm

Manufacturer	kwb Code	Part-No.	Ø x  mm	Teeth	 mm	 mm			Barcode	Quality
AEG DeWalt Elektra-Beckum ELU Emco Festo Flott Haffner Hanning Inca Mafell Makita Scheppach Skil Ulmia	M 93	589355	250 x 30	42	2,2	2,2		1	 4 0 09315 893556	★★★★★

Construction timber blade

- Tungsten carbide tipped
- Coarse teeth
- Zero hook
- For bench and table saws
- Quick, coarse cut

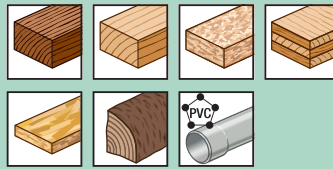

- Solid wood
- Blockboard, chipboard, fibreboard
- Glass-fibre reinforced plastics

K

Circular saw blades for bench- and table saws Ø 250 up to Ø 500 mm

Manufacturer	kwb Code	Part-No.	Ø x  mm	Teeth	 mm	 mm			Barcode	Quality
AEG DeWalt Einhell Elektra-Beckum ELU Emco Ferm Festo Flott Haffner Hanning Inca Mafell Makita Metabo Niko Scheppach Skil Ulmia	K 93	589344	250 x 30	24	2,8	1,8		1	 4 009315 893440	★★★★★

Construction timber blade



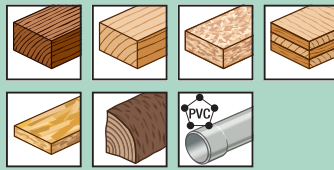













- Tungsten carbide tipped
- Coarse teeth
- Zero hook
- For bench and table saws
- Quick, coarse cut



- Solid wood
- Blockboard, chipboard, fibreboard
- Glass-fibre reinforced plastics

K

Circular saw blades for bench- and table saws Ø 250 up to Ø 500 mm

Manufacturer	kwb Code	Part-No.	Ø x  mm	Teeth	 mm	 mm			Barcode	Quality
DeWalt Flott Haffner Holz-Her Metabo Scheppach Schleicher Skil Striebig Ulmia	K 930	593044	300 x 30	28	2,8	1,8		1	 4 009315 930442	★★★★★
AL-KO Atika Einhell Elektra-Beckum Flott Haffner Hanning Hitachi Lescha Lutz Mafell Makita Metabo Scheppach Ulmia	K 931	593144	315 x 30	28	2,8	1,8		1	 4 009315 931449	★★★★★
DeWalt Festo Holz-Her Mafell Makita Ulmia	K 935	593544	350 x 30	32	3	2		1	 4 009315 935447	★★★★★
Atika DeWalt Elektra-Beckum ELU Festo Haffner Holz-Her Lutz Mafell Scheppach Wegoma	K 940	594044	400 x 30	36	3,2	2,2		1	 4 009315 940441	★★★★★
AL-KO Atika Elektra-Beckum Festo Lutz Mafell Scheppach	K 945	594544	450 x 30	40	3,5	2,5		1	 4 009315 945446	★★★★★
AL-KO Atika DeWalt Elektra-Beckum ELU Haffner Lutz Mafell Scheppach Wegoma	K 951	595144	500 x 30	44	3,5	2,5		1	 4 009315 951447	★★★★★

Circular saw blades for bench- and table saws

Moulding blade















- Chrome vanadium
- Pointed teeth
- Positive hook
- for hand-held, bench and table saws
- Fine, precise cut



- Softwood
- Plywood
- Panels
- Mouldings

B

Circular saw blades for bench- and table saws Ø 250 up to Ø 500 mm

Manufacturer	kwb Code	Part-No.	Ø x  mm	Teeth	 mm	 mm			Barcode	Quality
AEG B & D Bosch DeWalt Einhell Elektra-Beckum ELU Emco Festo Flott Haffner Hanning Inca Mafell Makita Metabo Niko Scheppach Skil Ulmia	B 93	589311	250 x 30	80	2,4	1,4		1	 4 009315 893112	★★★★★
DeWalt ELU Flott Haffner Holz-Her Metabo Scheppach Schleicher Skil Striebig Ulmia	B 930	593011	300 x 30	80	2,6	1,6		1	 4 009315 930114	★★★★★
AL-KO Atika Einhell Elektra-Beckum Flott Haffner Hanning Hitachi Lescha Lutz Mafell, Makita Metabo Scheppach Ulmia	B 931	593111	315 x 30	80	2,8	1,8		1	 4 009315 931111	★★★★★
DeWalt Festo Holz-Her Mafell, Makita Ulmia	B 935	593511	350 x 30	80	2,8	1,8		1	 4 009315 935119	★★★★★
Atika DeWalt Elektra-Beckum ELU Festo Haffner Holz-Her Lutz Mafell Scheppach Wegoma	B 940	594011	400 x 30	80	3	2		1	 4 009315 940113	★★★★★

... always the appropriate accessories for your machine!

Moulding blade



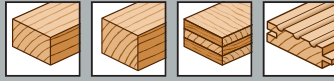





- Chrome vanadium
- Pointed teeth
- Positive hook
- for hand-held, bench and table saws
- Fine, precise cut



- Softwood
- Plywood
- Panels
- Mouldings

B

Circular saw blades for bench- and table saws Ø 250 up to Ø 500 mm

Manufacturer	kwb Code	Part-No.	Ø x  mm	Teeth	 mm	 mm			Barcode	Quality
AL-KO Atika Elektra-Beckum Festo Lutz Mafell Scheppach	B 945	594511	450 x 30	80	3,2	2,2		1	 4 009315 11945118	★★★★★
AL-KO Atika DeWalt Elektra-Beckum ELU Haffner Lutz Mafell Scheppach Wegoma	B 951	595111	500 x 30	80	3,5	2,5		1	 4 009315 11935119	★★★★★

Circular saw blades for bench- and table saws

Logging blade



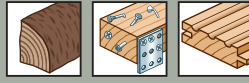











- Chrome vanadium
- Coarse teeth
- Positive hook
- For bench and table saws
- Quick, coarse cut



- Firewood
- Construction timber with nails
- Mouldings

C

Circular saw blades for bench- and table saws Ø 250 up to Ø 500 mm

Manufacturer	kwb Code	Part-No.	Ø x  mm	Teeth	 mm	 mm			Barcode	Quality
AEG Bosch DeWalt Einhell Elektra-Beckum ELU Emco Ferm Festo Flott Haffner Hanning Inca Mafell, Makita Metabo Niko Scheppach Skil Ulmia	C 93	589322	250 x 30	56	2,4	1,4		1	 4 009315 893228	★★★★★
DeWalt ELU Flott Haffner Holz-Her Metabo Scheppach Schleicher Skil Striebig Ulmia	C 930	593022	300 x 30	56	2,6	1,6		1	 4 009315 930220	★★★★★
AL-KO Atika Einhell Elektra-Beckum Flott Haffner Hanning Hitachi Lescha Lutz Mafell Makita Metabo Scheppach Ulmia	C 931	593122	315 x 30	56	2,8	1,8		1	 4 009315 931227	★★★★★
DeWalt Festo Holz-Her Mafell Makita Ulmia	C 935	593522	350 x 30	56	2,8	1,8		1	 4 009315 935225	★★★★★
Atika DeWalt Elektra-Beckum ELU Festo Haffner Holz-Her Lutz Mafell Scheppach Wegoma	C 940	594022	400 x 30	56	3	2		1	 4 009315 940229	★★★★★

... always the appropriate accessories for your machine!

Logging blade



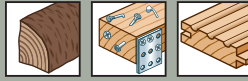





- Chrome vanadium
- Coarse teeth
- Positive hook
- For bench and table saws
- Quick, coarse cut



- Firewood
- Construction timber with nails
- Mouldings

C

Circular saw blades for bench- and table saws Ø 250 up to Ø 500 mm

Manufacturer	kwb Code	Part-No.	Ø x  mm	Teeth	 mm	 mm			Barcode	Quality
AL-KO Atika Elektra-Beckum Festo Lutz Mafell Scheppach	C 945	594522	450 x 30	56	3,2	2,2		1	 4 009315 1945224	★★★★★
AL-KO Atika DeWalt Elektra-Beckum ELU Haffner Lutz Mafell Scheppach Wegoma	C 951	595122	500 x 30	56	3,5	2,5		1	 4 009315 1951225	★★★★★

Circular saw blades for chop- and mitre saws

EASY CUT multi material blade



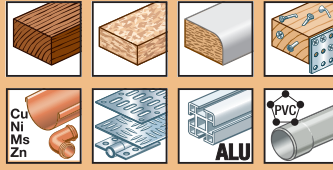









- tungsten carbide tipped
- special variable toothing
- zero hook
- suitable for all types of saw
- precise, clean cut



- Boards
- Laminated boards
- Construction timber
- Light alloy
- Thin sheet steel
- Aluminium profiles
- Plastics including Plexiglas

E

Circular saw blades for chop- and mitre saws, negative hook Ø 205 up to Ø 350 mm

Manufacturer	kwb Code	Part-No.	Ø x  mm	Teeth	 mm	 mm			Barcode	Quality
AEG B & D Bosch Elektra-Beckum ELU Fein Ferm Haffner Hitachi Holz-Her Mafell Metabo Skil Stayer	E 78	587833	210 x 30	34	2,8	1,8		1	 4 009315 878331	★★★★★
AEG DeWalt Einhell Elektra-Beckum ELU Emco Felisatti Festo Flott Haffner Hanning Hitachi Inca Kress Mac Allister Mafell, Makita Metabo Milwaukee Niko Scheppach Skil Stayer Ulmia Wegoma	E 93	589333	250 x 30	42	3	2		1	 4 009315 893334	★★★★★
DeWalt Felisatti Flott Haffner Hitachi Holz-Her Schleicher Skil Striebig Ulmia Wegoma	E 930	593033	300 x 30	48	3,2	2,2		1	 4 009315 930336	★★★★★
AL-KO Atika Elektra-Beckum Flott Haffner Hanning Hitachi Lescha Lutz Mafell Makita Metabo Scheppach	E 931	593133	315 x 30	48	3,2	2,2		1	 4 009315 931333	★★★★★

... always the appropriate accessories for your machine!

EASY CUT multi material blade



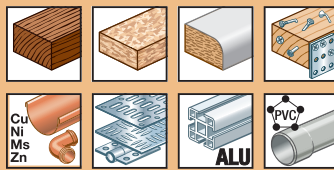



- tungsten carbide tipped
- special variable tothing
- zero hook
- suitable for all types of saw
- precise, clean cut



- Boards
- Laminated boards
- Construction timber
- Light alloy
- Thin sheet steel
- Aluminium profiles
- Plastics including Plexiglas

E

Circular saw blades for chop- and mitre saws, negative hook Ø 205 up to Ø 350 mm

Manufacturer	kwb Code	Part-No.	Ø x  mm	Teeth	 mm	 mm			Barcode	Quality
DeWalt Festo Haffner Holz-Her Mafell Makita Niko Schleicher Ulmia Wegoma	E 935	593533	350 x 30	54	3,2	2,2		1	 4 009315 935331	★★★★★

Moulding blade



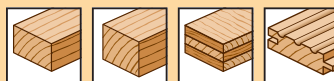



- Chrome vanadium
- Feinzahn
- Zahnstellung **negativ**
- für Kapp- und Gehrungssägen
- Fine, precise cut



- Softwood
- Plywood
- Panels
- Mouldings

A

Circular saw blades for chop- and mitre saws, negative hook Ø 210 up to Ø 300 mm











Manufacturer	kwb Code	Part-No.	Ø x  mm	Teeth	 mm	 mm			Barcode	Quality
Bosch DeWalt Felisatti Flott Haffner Hitachi Holz-Her Schleicher Skil Striebig Ulmia Wegoma	A 930	593000	300 x 30	96	2,6	1,6		1	 4 009315 930008	★★★★★

Circular saws

Bushings for circular saw blades



Reducing bushes for all common circular saw blades with centre bore 20mm down to 16mm, and with centre bore 30mm down to 16mm, 20mm and 25mm.

Art.-No.	∅ outside	∅ inside	±			Barcode
582016	20	16	1,2		2	
583016	30	16	1,2		2	
583020	30	20	1,2		2	
583025	30	25	1,2		2	



kwb-Info

A safer job



Whenever you work with circular saws, saw benches, table saws or with chop- and mitre saws the chips will fly in the truest sense of the word. That's why the eyes as one of our most important sensory organs must be protected whichever of these types of saw we're using. That's why kwb has put together a comprehensive eye protection range, also suitable for spectacle wearers.

Of course you also need safety eyewear for other jobs such as drilling, milling, sanding, welding whether indoors or outside.

You can find further information in our kwb **Personal Protection catalogue** or on the Internet at www.kwb.eu.



... always the appropriate accessories for your machine!





CHAINSAW CHAINS

Chainsaw chains



The benefits of chainsaw chains

- **Saw chains for electric and petrol machines**
Saw chains for professional forestry use and DIY. Keep their sharpness, with long working life even in hardwood. The sharpening angle marks on the links make sharpening easier.

Always the right chain for every chainsaw

Guide bar length	Drive link width	Spacing
30 cm	1,1 MM, 1,3 MM	3/8"
35 cm	1,1 MM, 1,3 MM	3/8"
38 cm	1,1 MM, 1,3 MM, 1,5 MM	3/8", .325
40 cm	1,1 MM, 1,3 MM, 1,5 MM, 1,6 MM	3/8", .325

How do you pick out the correct saw chain?

When buying a saw chain it comes down to the spacing and number of links (= length). In addition you have to get the correct link thickness.



z.B. 3/8"

Spacing:

To measure the spacing, you need to measure the distance from the middle of one rivet to the middle of the next-but-one rivet and divide this figure by two. The result is the spacing in millimetres, which is internationally denominated in inch measurements.



z.B. 44

Drive links:

The parts of the chain which run in the groove of the chainsaw bar are described as drive links. The length of the saw chain is classified by the number of links.

z.B. 1,3 MM



Drive link thickness:

The drive link thickness is the width of the links which run in the groove of the chainsaw bar. With 3/8" saw chains this can be 1.3mm or sometimes 1.1mm. With .325" and 3/8" saw chains 1.3mm, 1.5mm and 1.6mm (extra heavy duty chains) are possible.

Saw Chains for chain saws



Art.-No.	kwb part no.	Guide bar length	Graduation	Links	Link thickness			Barcode
HOBBY								
640344	A-44	30	3/8"	44	1,3		1	
640345	A-45	30	3/8"	45	1,3		1	
640346	A-46	30	3/8"	46	1,3		1	
640349	A-49	35	3/8"	49	1,3		1	
640350	A-50	35	3/8"	50	1,3		1	
640352	A-52	35	3/8"	52	1,3		1	
640355	A-55	40	3/8"	55	1,3		1	
640356	A-56	40	3/8"	56	1,3		1	
640357	A-57	40	3/8"	57	1,3		1	
640644	C-44	30	3/8"	44	1,1		1	
640650	C-50	35	3/8"	50	1,1		1	
640652	C-52	35	3/8"	52	1,1		1	

Art.-No.	kwb part no.	Guide bar length	Graduation	Links	Link thickness			Barcode
PROFI								
640864	D-64	38	.325	64	1,3		1	
641262	G-62	38	.325	62	1,6		1	
641756	L-56	38	3/8"	56	1,5		1	
641856	M-56	33	3/8"	56	1,6		1	
641860	M-60	40	3/8"	60	1,6		1	

Chains for chainsaws are ideal for use in tree felling, pruning, construction, joinery and wood sculpture. To prolong the life of the chainsaw bar, the chain must be regularly oiled when in use.



kwb-Info



A safe job

Please make sure you equip yourself with the right safety kit when using chainsaws:- headfuard with visor, gloves and hearing protection.

kwb-Info





The right protection

To prolong the life of the chainsaw bar, it is vital to oil the chain regularly.





Kwb has just the right saw chain oil.







Part.-no. 939110





Manufacturer/machine model	Guide bar length cm	Spacing 	Drive links 	Drive link width 		kwb quick reference number	Part-No.
ALKO							
KB350, KB450, 3500, 4000, 4500, KB3501, 4001, 5001							
E 25A, E 1200 S, E 125, E 1400, E 1500, EK 25 A, KB 3500, KB 4000, KB 4001, KB 4500, KB 4501, KE 14, KE 16, KE 18, KSB 1450, P11, P12, 2000, 2300, 3000, KS, KSB, Elektro							
ALPINA-CASTOR							
EL140, EL160, EL170, 300, 330, 380, 423, 432, 438, CP34S, P34, P34S, P350, P380, P438, PR350, PR370, Euro35, Euro40, Euro45, KS300, KS350, CX35, CX40, CX 45, Energie 1.6, E1.8, Jolly40 Garden Ranger							
BLACK & DECKER							
CS30, CS35, D35KS, D40KS, DN301, DN302, DN400, DN401, DN402, DN402/B, DN404, DN404/B, DN404-TypH2, DN410, DN412, DN416, DN 430, GK30, GK40, GK100/110, GK120, GK130, GK300, GK31, GK310, GK320, GK321, GK322, GK330, GK331, GK3300, GK35, GK42, GK43, GK430, GK425, GK435, GK440, GK535, GK540, 5400, 8308, 8310, 8312, 8314, GK1300K, GK1330, GK1440, GK1530, GK1630T, GK1430, GK1435, GK1630 XC, GK1635, GK1830, Pro40							
GK1430, GK1300							
BEL PICKPINE							
16							
BLITZ							
B 300, B 304, B 34, E 140F							
BOSCH							
EKS 1535, 1540, KS 300							
BULLKRAFT							
KSE 30, KS 300, KSE 1300B, GK 30, KSM 25, 300 S							
CASTEL GARDEN							
XC 35P							
DYNAMAC							
30F, E 140F							
EFCO							
114E, 134, 135, 116							
FARM U. GARTEN	30	3/8"	44	1,3	ø 4,0	A44	640344
P349, PR350							
FOLUX							
F 30F							
GRIZZLY							
BKS 35-12							
HANDY							
30HF, E 140F							
IKRA							
MKS 30							
MCCULLOCH							
Electramac 16-EE, ES 30, 22, 24, 26, 35, 36, 40, PM-394, PM-494, M 1, 2, 2B, 4, 4B, 6, 6B, Californian, Arizona, Eager-Beaver, 10, 12, 12 A/S, 14 AVS, 16 E, 170, 374, 384, 394, 484, 494, 735, 930, 935, C 180, EM-8							
Mac110, 120, 130, 140, 160, PM300, PM310, PM320, PM330, PM340, PM360, PM364, PM370, PM380, PM394, PM470, PM474, PM480, PM484, PM494, PM530, PM538, PM540, 832, 833, 835, 836, 838, 839, 930, Euromac S32, S33, S34, S36, S40, S41, ELECTR							
METABO							
5338 B							
OLEO MAC OLYM.							
35, 233, 234, 240, 241, 244, 335, 340, 930, 935D, 935X, 935DX, E140F, E160F, E170F, E1700, E170, E1900, E-200							
936, 940C, E140							
PARTNER							
1400E, 1500-EL, 1601, 1602, 1612, 1613, 1614, 1616, 1618							
RYOBI							
35B, CS 36C, CS 41, CSE 330, CSE 3330, CSE 385CB, HC 31, HCS 31, HC 36, HC 41, CS 1530, CS 1535, CS 1540							
CS 290, C 300, CS1530							
STARK-SYMPRA-SYMPRATEC							
1400, 1412, 1430, 14830							





Saw chains classified by bar length kwb Part no./ Manufacturer

Manufacturer/machine model	Guide bar length cm	Spacing 	Drive links 	Drive link width 		kwb quick reference number	Part-No.
STEINMAX	30	3/8"	44	1,3	ø 4,0	A44	640344
CS 300							
STIGA							
SP 340							
STIHL							
009, 010, 011, 012, 015, 018C, 019, 020, 020/T, 021, 023, 023C, 023L, 025, 025C, E 10, E 14, E 20, E 140, E 160, E 180, E 180C, E 220, E 220C, MS 180C, MS 190, MS 190T, MS 200, MS 200T, MS 210, MS 211, MS 230, MS 250, MSE 160, MSE 180, MSE 200, AVH-Elektronik							
TECHNIC TOOL							
PP 1250							
AEG							
KS 30							
ALKO							
Hobby 320, E135, E1200E, 1400E, 1500E							
E 25A, E 1200 S, E 125, E 1400, E 1500, EK 25 A, KB 3500, KB 4000, KB 4001, KB 4500, KB 4501, KE 14, KE 16, KE 18, KSB 1450, P11, P12, 2000, 2300, 3000, KS, KSB, Elektro							
ALPINA-CASTOR							
A10, A10E, A12, A12E, A14, A14E, E100, E120, E130, E150, E160, E170, KS1400B, KS1500B, P360, P390							
BLACK & DECKER							
CS30, CS35, D35KS, D40KS, DN301, DN302, DN400, DN401, DN402, DN402/B, DN404, DN404/B, DN404-TypH2, DN410, DN412, DN416, DN 430, GK30, GK40, GK100/110, GK120, GK130, GK300, GK31, GK310, GK320, GK321, GK322, GK330, GK331, GK3300, GK35, GK42, GK43, GK430, GK425, GK435, GK440, GK535, GK540, 5400, 8308, 8310, 8312, 8314, GK1300K, GK1330, GK1440, GK1530, GK1630T, GK1430, GK1435, GK1630 XC, GK1635, GK1830, Pro40							
L10							
BOSCH							
AES 35, AKE 30B, AKE 30E, AKE 30-19Pro, AKE 30-16S, AKE 35B, AKE 40B, AKE 300B, PKE 10B, PKE 25, PKE 30 PowerSharp, PKE 30B, PKE 35B, PKE 40B, PKE 40BC, PKE 1350B, GKE 35BC, 1586							
BUDGET							
BKS 301							
DOLMAR							
101, 200, 201, 260, 290							
101 PowerSharp							
ECHO							
CS 200E, CS 280E, CS 280EVL, CS 290EVL, CS 300, CS 302, CS 320, CS 3000, CS 3050							
EFCO							
131							
136, 140							
EINHELL							
CS 280, EKS 35, EKS 35-1, MKS 30, MKS 34, PE 34/2, PE 35/3ZS, PES 2000, PES 30/2, PES 30-2, PES 34/3, PES 34/2, PES 34/3, PES 35, PES 35/2TS, PES 35-2, PES 35-3, PES 40S, PKS 35-1AV, PES 40/3, PES 1435, PES 1540, PES 1640, PES 1540, PES 1640, PES 1840, KSE 1435, KSE 1635, KSE 1640, KSE 2000, KSE 3000, KSE 4000							
FRONTIER							
MK 1=Quadra							
HITACHI							
CS 280A, CS 280B							
HOMELITE							
i335, i3350B, D 3850B, D 3850BC, 23AV, Sabre S 3350B, S 1035							
HUSQUARNA							
Husky 33, Husky 34							





Manufacturer/machine model	Guide bar length cm	Spacing 	Drive links 	Drive link width 		kwb quick reference number	Part-No.
IKRA							
KS30ST, KS400, KS12A, A104P PowerSharp, A104A							
A104P+S, A204S, A205B, FA12, FA14, KS12, H014S, KS14, KS30ST, KS400, KS1200B, KS1250B, KS1300, Shark1300, KS1400, KS1400A, KS1400B, KS1500, KS1600, KS2000, 1200KS, Shark PE1400, Sup-Pro 1500, KS1500T, KS 1500TS, KS1700DL, KSE2000, EKS30, EKS35, EKS40, EKS1500-35, EKS1400, EKS1600, EKS1650, EKS1700, EKS1800, EKS2000, BKS301, BKS402, BKS4135, PKS40							
JONSERED							
2033, 370, 380, CS2115EL, CS2120EL, CS2137							
KOMATSU ZENOAH							
G31AVS, G310TS, G3100, G3200, G3300, G380AVS, G3800, G2800AVS							
SDK 100							
Electric 5011B, Electric 5012B, Electric, 5014-NB, Electric 5016-B, Electric 5016-NB							
MCCULLOCH							
Electramac 230/1030, 230, 312, 312s, 330, 1030, ES22, S12, Mac 930/12, Euromac 30/E30/ES30, Euromac S12, PM 360/364/730/930							
OLEO MAC OLYM.							
931, 932, 932C							
OPEM							
130Z							
PARTNER							
1400E, 1500-EL, 1601, 1602, 1612, 1613, 1614, 1616, 1618							
330, 335, 340, 345, 350, 351, 357, 360, 365, 370, 371, 385, 389, 390, 405, P-420, P 740, P 842, P842CC							
341, 395, 420, 1200, 1450							
PEUGEOT							
TLS 1630, TRC 1630, TLS 1635, TLS 1635A, TRC 1635, TLS 1640, TRC 1640, EKS1740							
POULAN							
Micro 25, Micro 25A							
REMINGTON							
860 AV, Cutter, EL6 DELUXE							
SHINDAIWA-SDK-ISEKI							
140, 160, 285s, 300s, 305s, 305AVZ, 340, 345, 346, 350, 352s, 355, 357, 357s, 360, 377, 391, 395, A-090, 102, 103, 104, 105, 107, 110, 110P, 113L+P, 117P, 100, E 150, 315, YB 301, YB 401, A 090B, A 100C, A 102, A 150B							
SKIL							
1600HE, 1601HE, 1602HE, 1603H, 1604H, 1606H, 1610U, 1612U, 1616U, 1620U, 1634U, 1636U, 1712U							
SOLO							
613, 614, 620, 630, 633, 635, 635ECO, 636, 637, 640, 643							
STIGA							
930							
TALON							
AC2101, AC2105, AC2109, AC2111, AC3100							
TAS-TANAKA							
290, 300, ECS 320, ECS 330, ECS 3301, ECS 3351, ECS 3401, TCS 3301S, TCS 3401							
DOLMAR							
33, 40, 100, 100s, 102, 103, 104, 105, 108, 270, 271, 275, 285, 290, 295, ES 3, ES 6A, ES 30, ES 32A, ES 33A, ES 35, ES 37A, ES 38A, ES 40A (ab 09/01), ES 41A, ES 42A, ES 140, ES 151A, ES 152A, ES 153A, ES 160, ES 160A, ES 161A, ES 162A, ES 163A, ES 171A, ES 172A, ES 173A, ES 183A, ES 1600, ES 2030A, ES 2035A, ES 2040A, ES 2135A, ES 2140A, PS 33, PS 34, PS 36, PS 41, PS 45 (1,3mm), PS 39, PS 330, PS 340, PS 341, PS 342, PS 344, PS 350, PS 390, PS 400, PS 401, PS 3300TH, PS 3410, PS 3500TH, PS 3400TH, PS 3410TH							





Saw chains classified by bar length kwb Part no./ Manufacturer

Manufacturer/machine model	Guide bar length cm	Spacing 	Drive links 	Drive link width 		kwb quick reference number	Part-No.
MAKITA DCS 33, DCS 34, DCS 300, DCS 330, DCS 330S, DCS 330TH, DCS 340, DCS 341, DCS 342, DCS 344, DCS 350, DCS 380, DCS 390, DCS 400, DCS 401, DCS 3300TH, DCS 3400TH, DCS 3401TH, DCS 3500, DCS 3501, DCS 4610, DES 350, DES 400, UC 300, UC 3000, UC 3000A, UC 3001A, UC 3003A, UC 3500, UC 3500A, UC 3501A, UC 3503A, UC 4000, UC 4000A, UC 4001A, UC 4003A, 5014B, 5016B, 5016NB	30	3/8"	46	1,3	ø 4,0	A46	640346
ZENOAH G 300T, G 300AVS							
ALKO KB350, KB450, 3500, 4000, 4500, KB3501, 4001, 5001							
ALPINA-CASTOR EL140, EL160, EL170, 300, 330, 380, 423, 432, 438, CP34S, P34, P34S, P350, P380, P438, PR350, PR370, Euro35, Euro40, Euro45, KS300, KS350, CX35, CX40, CX 45, Energie 1.6, E1.8, Jolly40 Garden Ranger							
BLACK & DECKER CS30, CS35, D35KS, D40KS, DN301, DN302, DN400, DN401, DN402, DN402/B, DN404, DN404/B, DN404-TypH2, DN410, DN412, DN416, DN 430, GK30, GK40, GK100/110, GK120, GK130, GK300, GK31, GK310, GK320, GK321, GK322, GK330, GK331, GK3300, GK35, GK42, GK43, GK430, GK425, GK435, GK440, GK535, GK540, 5400, 8308, 8310, 8312, 8314, GK1300K, GK1330, GK1440, GK1530, GK1630T, GK1430, GK1435, GK1630 XC, GK1635, GK1830, Pro40 GK1635TX, GK1635TG, GK1435 L10							
BEL PICKPINE 34, 16							
BLITZ B 35D, B 38							
BONUS KSB 35							
BULLKRAFT KSE 1300B, BES 1300B, KS 350, KS 350/2							
DYNAMAC 35F							
EFCO 114E, 134, 135, 116	35	3/8"	49	1,3	ø 4,0	A49	640349
EINHELL AC 31114, BKS 38/35, MKS 35, PBK 35/35							
FLEURELLE KSB 1735							
FOLUX F 35, F 35F							
GRIZZLY Farmer MKS 350, BKS 35-14, BKS 38-14, BKS 38-16, EKS 1600, EKS 1800, EKS 400I, EKS 400TL, EKS 2000, P390, BKS 350, BKS 400, KSI 2000							
HANDY 35 HF							
HURRICANE MKS 38/35							
HUSQUARNA CMI 1735BKS, BKS 35-14, KS 1938/35							
MCCULLOCH E14, Electramac14E, ES80, 230, 1030, S22, ES30, Euromac35, 833, S12, S33, S34, Mac12, 130, 140, 833, 835, 836, Mini Mac30, Mini Mac833, PM730, Titan7 Electramac 16-EE, ES 30, 22, 24, 26, 35, 36, 40, PM-394, PM-494, M 1, 2, 2B, 4, 4B, 6, 6B, Californian, Arizona, Eager-Beaver, 10, 12, 12 A/S, 14 AVS, 16 E, 170, 374, 384, 394, 484, 494, 735, 930, 935, C 180, EM-8 Mac110, 120, 130, 140, 160, PM300, PM310, PM320, PM330, PM340, PM360, PM364, PM370, PM380, PM394, PM470, PM474, PM480, PM484, PM494, PM530, PM538, PM540, 832, 833, 835, 836, 838, 839, 930, Euromac S32, S33, S34, S36, S40, S41, ELECTR							





Manufacturer/machine model	Guide bar length cm	Spacing 	Drive links 	Drive link width 		kwb quick reference number	Part-No.
OLEO MAC OLYM.	35	3/8"	49	1,3	ø 4,0	A49	640349
35, 233, 234, 240, 241, 244, 335, 340, 930, 935D, 935X, 935DX, E140F, E160F, E170F, E1700, E170, E1900, E-200							
936, 940C, E140							
REMINGTON							
Mighty Mite 500/812/814							
RYOBI							
35B, CS 36C, CS 41, CSE 330, CSE 3330, CSE 385CB, HC 31, HCS 31, HC 36, HC 41, CS 1530, CS 1535, CS 1540							
CSE 385CB, HC 36, CS 360, CS1535							
SHARK							
BKS3540							
STARK-SYMPRA-SYMPRATEC							
1414, 1435, 14350, 14835							
STEINMAX							
CS 360							
TALON							
AC2101, AC2105, AC2109, AC2111, AC3100							
UNIROPA							
BKS3840							
ALKO	35	3/8"	50	1,3	ø 4,0	A50	640350
E 25A, E 1200 S, E 125, E 1400, E 1500, EK 25 A, KB 3500, KB 4000, KB 4001, KB 4500, KB 4501, KE 14, KE 16, KE 18, KSB 1450, P11, P12, 2000, 2300, 3000, KS, KSB, Elektro							
ALPINA-CASTOR							
A10, A10E, A12, A12E, A14, A14E, E100, E120, E130, E150, E160, E170, KS1400B, KS1500B, P360, P390							
EL140, EL160, EL170, 300, 330, 380, 423, 432, 438, CP34S, P34, P34S, P350, P380, P438, PR350, PR370, Euro35, Euro40, Euro45, KS300, KS350, CX35, CX40, CX 45, Energie 1.6, E1.8, Jolly40 Garden Ranger							
BULLKRAFT							
KS 350, KS 350/2, KS 400, KS 400/2							
CASTEL GARDEN							
XC 18EL, XC 20EL, XC 35P, XC 36, XC 37							
DOLMAR							
101, 200, 201, 260, 290							
EFCO							
117E, 119E							
EINHELL							
MKS 35, PES 1435							
EUROMAC							
S 14/35/ES 35/ES 24/530, PM 370/374/470/474/735, Titan 35, E35							
FARM U. GARTEN							
P349, PR350							
160EL, 165EL, 170EL, 180EL, 360P, 370P, 390P							
GRIZZLY							
BKS 35-32, BKS 35-38, PKS 360/390, EKS 2500QT							
IKRA							
MKS 35, KS1300Shark							
MCCULLOCH							
Electramac235, 1035, 35, Euromac530, S14, Mac Cut, Mac 538, 538a, 538e, 540, 545, 545e, 546, California, California 2000/Kit, 930,935, PM36, 370, 374, 470, 474, 486, 735, Titan35, PM 1-10, 2-10, 3-10, 4-10, 5-10, 6-10, 7-10, 10-10, 55, PM60, 70, 80, 81, 555, PM570, 610, 650, 655, PM700, 800, 805, 850, PM1000, DE-50, SP-60, Titan 50, 57							
Electramac 16-EE, ES 30, 22, 24, 26, 35, 36, 40, PM-394, PM-494, M 1, 2, 2B, 4, 4B, 6, 6B, Californian, Arizona, Eager-Beaver, 10, 12, 12 A/S, 14 AVS, 16 E, 170, 374, 384, 394, 484, 494, 735, 930, 935, C 180, EM-8							





Saw chains classified by bar length kwb Part no./ Manufacturer

Manufacturer/machine model	Guide bar length cm	Spacing 	Drive links 	Drive link width 		kwb quick reference number	Part-No.							
MCCULLOCH PM 1-10, 2-10, 3-10, 4-10, 5-10, 6-10, 7-10, 10-10, 55, PM60, 70, 80, 81, 555, PM570, 610, 650, 655, PM700, 800, 805, 850, PM1000, DE-50, SP-60, Titan 50, 57	35	3/8"	50	1,3	ø 4,0	A50	640350							
OLEO MAC OLYM. 35, 233, 234, 240, 241, 244, 335, 340, 930, 935D, 935X, 935DX, E140F, E160F, E170F, E1700, E170, E1900, E-200														
PARTNER 1400E, 1500-EL, 1601, 1602, 1612, 1613, 1614, 1616, 1618 330, 335, 340, 345, 350, 351, 357, 360, 365, 370, 371, 385, 389, 390, 405, P-420, P 740, P 842, P842CC 341, 395, 420, 1614 P1535, P1550, 1640, P1850, P538, 538E														
PEUGEOT TLS 1630, TRC 1630, TLS 1635, TLS 1635A, TRC 1635, TLS 1640, TRC 1640, EKS1740														
REMINGTON Electricpower, Limb`n`-Trim, 1450														
SHARK 1300-35														
SOLO 634, E-105, KSB 2035														
STIGA 935, SP 340, SE 1.6 SE 1.8, SE180, SE 190, SE 200Q, SP 370, SP 410, SPR 350														
STIHL 009, 010, 011, 012, 015, 018C, 019, 020, 020/T, 021, 023, 023C, 023L, 025, 025C, E 10, E 14, E 20, E 140, E 160, E 180, E 180C, E 220, E 220C, MS 180C, MS 190, MS 190T, MS 200, MS 200T, MS 210, MS 211, MS 230, MS 250, MSE 160, MSE 180, MSE 200, AVH-Elektronik														
AEG KSE 35, KS 35								35	3/8"	52	1,3	ø 4,0	A52	640352
ALKO BKS 35/35 II, KE 2000/35, KE40-16/11, KE1400/35, KE1600/35 E 25A, E 1200 S, E 125, E 1400, E 1500, EK 25 A, KB 3500, KB 4000, KB 4001, KB 4500, KB 4501, KE 14, KE 16, KE 18, KSB 1450, P11, P12, 2000, 2300, 3000, KS, KSB, Elektro														
ALPINA-CASTOR A10, A10E, A12, A12E, A14, A14E, E100, E120, E130, E150, E160, E170, KS1400B, KS1500B, P360, P390														
ASGATEC 1400, 1600, 1801, 1840, 2001, 2040														
BOSCH AES 35, AKE 30B, AKE 30E, AKE 35B, AKE 35-16S, AKE 35-17, AKE 35-19Pro, AKE 40B, AKE 350B, GKE 35, GKE 35BC, GKE 35 BCE, PKE 10B, PKE 25, PKE 30B, PKE 35 PowerSharp, PKE 35B, PKE 40B, PKE 40BC, PKE 1350B, 1586.7														
BUDGET BBKS 1235														
DOLMAR 101, 200, 201, 260, 290 33, 40, 100, 100s, 102, 103, 104, 105, 108, 270, 271, 275, 285, 290, 295, ES 3, ES 6A, ES 30, ES 32A, ES 33A, ES 35, ES 37A, ES 38A, ES 40A (ab 09/01), ES 41A, ES 42A, ES 140, ES 151A, ES 152A, ES 153A, ES 160, ES 160A, ES 161A, ES 162A, ES 163A, ES 171A, ES 172A, ES 173A, ES 183A, ES 1600, ES 2030A, ES 2035A, ES 2040A, ES 2135A, ES 2140A, PS 33, PS 34, PS 36, PS 41, PS 45 (1,3mm), PS 39, PS 330, PS 340, PS 341, PS 342, PS 344, PS 350, PS 390, PS 400, PS 401, PS 3300TH, PS 3410, PS 3500TH, PS 3400TH, PS 3410TH														
104 PowerSharp														
ECHO CS 3400, CS 3450, CS 4400, CS 1550FT, CS 1850FT														





Manufacturer/machine model	Guide bar length cm	Spacing 	Drive links 	Drive link width 		kwb quick reference number	Part-No.
EFCO							
136, 140							
EINHELL							
36GS, KSE 1435, KSE 1635, PE 35/3TS, PES 1435, PES 3000, PES 4000, PKS 1635, PKS 34/1AV, P35, RBK 3735, BG-PC 1235, BG-PC 3735, GH-EC 1835, RPC 3835, PES 40/3, PES 1435, PES 1540, PES 1640, PES 1540, PES 1640, PES 1840, KSE 1435, KSE 1635, KSE 1640, KSE 2000, KSE 3000, KSE 4000							
EK							
1535, Migros E 35, KSE 1435							
FARM U. GARTEN							
150EL							
FLEURELLE							
KS1435, KS1640, KSE1640, KSE1845, KSE2040-1, KSB2035, KSB2640							
GARDENA							
CST 3518, CST 3519-X							
HITACHI							
CS 350A, CS 350B							
HOMELITE							
i335, i3350B, D 3850B, D 3850BC, 23AV, Sabre S 3350B, S 1035, HCS 3435BA, CSP 3314, Bandit BSC 35, BanditXLX30, ECW 1636, HCS 3335, XL2 Super, XL, XEL, XLTI, 240SL							
HURRICANE							
HEK 18-35							
HUSQUARNA							
Husky 35, Hisky 36, 315, 316, 318, 320 Electric							
IKRA							
A104P+S, A204S, A205B, FA12, FA14, KS12, H014S, KS14, KS30ST, KS400, KS1200B, KS1250B, KS1300, Shark1300, KS1400, KS1400A,KS1400B, KS1500, KS1600, KS2000, 1200KS, Shark PE1400, Sup-Pro 1500, KS1500T, KS 1500TS, KS1700DL, KSE2000, EKS30, EKS35, EKS40, EKS1500-35, EKS1400, EKS1600, EKS1650, EKS1700, EKS1800, EKS2000, BKS301, BKS402, BKS4135, PKS40	35	3/8"	52	1,3	ø 4,0	A52	640352
KS14A, H014A, A104P PowerSharp							
KS1600-35, KS1600-40, KS1800-40, KSE2000-35, KSE2000-40, KSE2000-45, KS1500TS							
BKS4141							
KS1400T, KS1500T							
EL1400, Hobby Cutter, KS1200B, KS1250, KS1400A, KS1400T, KS1400TF, KS1435, KS1600T-35, KS1600TF-35,KS1600TS-35, KS14A, A104P PowerSharp							
JONSERED							
2036, 2040, 2033, 370, 380, CS2115EL, CS2120EL, CS2137							
KOMATSU ZENOAH							
G31AVS, G310TS, G3100, G3200, G3300, G380AVS, G3800, G2800AVS							
MAKITA							
Electric 5011B, Electric 5012B, Electric, 5014-NB, Electric 5016-B, Electric 5016-NB							
DCS 33, DCS 34, DCS 300, DCS 330, DCS 330S, DCS 330TH, DCS 340, DCS 341, DCS 342, DCS 344, DCS 350, DCS 380, DCS 390, DCS 400, DCS 401, DCS 3300TH, DCS 3400TH, DCS 3401TH, DCS 3500, DCS 3501, DCS 4610, DES 350, DES 400, UC 300, UC 3000, UC 3000A, UC 3001A, UC 3003A, UC 3500, UC 3500A, UC 3501A, UC 3503A, UC 4000, UC 4000A, UC 4001A, UC 4003A, 5014B, 5016B, 5016NB							
MCCULLOCH							
Mac 335, 435, MacCat 438							
NAUTEC							
131							
OBI-CMI							
CMI 1735BKS, 2115, EKS 1800-35							
OBI-DIANA							
1300-35KS							





Saw chains classified by bar length kwb Part no./ Manufacturer

Manufacturer/machine model	Guide bar length cm	Spacing 	Drive links 	Drive link width 		kwb quick reference number	Part-No.
OLEO MAC OLYM.							
937							
931, 932, 932C							
935, 936, 940							
OPEM							
140Z, 142Z							
PARTNER							
330, 335, 340, 345, 350, 351, 357, 360, 365, 370, 371, 385, 389, 390, 405, P-420, P 740, P 842, P842CC							
1601,1602, 1612, 1613, 1614, 1616, 1618, 395, 420, 465							
POULAN							
25A, S 25D, S 25DA, 1400E, 2000, 2300AV, 2300CVA, P 600, 2050, 2150, 2250, 2450, 2550, Woodshark, Pro4016							
RYOBI							
CSP 3314, ECW 1636, PCN 3335, RCS 3335							
SABRE							
S 3350B, 1035, CS 35, BCS 35							
SHINDAIWA-SDK-ISEKI							
140, 160, 285s, 300s, 305s, 305AVZ, 340, 345, 346, 350, 352s, 355, 357s, 360, 377, 391, 395, A-090, 102, 103, 104, 105, 107, 110, 110P, 113L+P, 117P, 100, E 150, 315, YB 301, YB 401, A 090B, A 100C, A 102, A 150B	35	3/8"	52	1,3	ø 4,0	A52	640352
SHINGU							
SP 3200, SP 3200T, SP 3400							
SKIL							
1600HE, 1601HE, 1602HE,1603H, 1604H, 1606H, 1610U, 1612U, 1616U, 1620U, 1634U, 1636U, 1712U							
SOLO							
613, 614, 620, 630, 633, 635, 635ECO, 636, 637, 640, 643							
TALON							
AC2101, AC2105, AC2109, AC2111, AC3100							
TAS-TANAKA							
290, 300, ECS 320, ECS 330, ECS 3301, ECS 3351, ECS 3401, TCS 3301S, TCS 3401							
TURBO SILENT							
BKS3536							
UNIROPA							
KSE2035, KSI1800-35, KSE2040, KSI20-40							
VARIOLUX							
2135KSE, 2140KSE, 2335BKES, 2340BKES							
ZENOAH							
G 310TS, G 320AV, G 320AVS, G 3100, G 3200							





Manufacturer/machine model	Guide bar length cm	Spacing 	Drive links 	Drive link width 		kwb quick reference number	Part-No.
ALPINA-CASTOR EL140, EL160, EL170, 300, 330, 380, 423, 432, 438, CP34S, P34, P34S, P350, P380, P438, PR350, PR370, Euro35, Euro40, Euro45, KS300, KS350, CX35, CX40, CX 45, Energie 1.6, E1.8, Jolly40 Garden Ranger	40	3/8"	55	1,3	ø 4,0	A55	640355
BLACK & DECKER CS30, CS35, D35KS, D40KS, DN301, DN302, DN400, DN401, DN402, DN402/B, DN404, DN404/B, DN404-TypH2, DN410, DN412, DN416, DN 430, GK30, GK40, GK100/110, GK120, GK130, GK300, GK31, GK310, GK320, GK321, GK322, GK330, GK331, GK3300, GK35, GK42, GK43, GK430, GK425, GK435, GK440, GK535, GK540, 5400, 8308, 8310, 8312, 8314, GK1300K, GK1330, GK1440, GK1530, GK1630T, GK1430, GK1435, GK1630 XC, GK1635, GK1830, Pro40							
BONUS KSE 2000 S							
BUDGET BKS 402							
BULLKRAFT KS 40S, KS 400S, KSE 1300B, KSM 40							
EINHELL PES 1840, REK 2040WK, PES 1540, PES 1640, BG-PC 4040							
FLEURELLE KSB 2340							
GRIZZLY EKS 2000, EKS 2000QT, BKS 38-16, BKS 35-14, BKS 38-14, EKS 1600, EKS 1800, EKS 400i, EKS 400TL, P390, BKS 350, BKS 400, KS 400i, KSI 2000							
GRIZZLY-LIDL Parkside EKS 1700							
HURRICANE ES 2040S							
IKRA BKS 38-16							
LIDL KSE1435, 1640, PKS 2000/4							
MCCULLOCH Electramac 240, 316, 316a, 340E, 1040, ES28, S16, Mac 538, 538e, 539e, 540, 540e, 545, 545e, 546, 838, 940, Mac Cat 839, California, California 2000/Kit, KSB2340, Mac6, Mac6B, Mac740, Mac940, PM486, EM30, Mac12, Mac28, MiniMac832, Titan7							
MCCULLOCH Electramac 16-EE, ES 30, 22, 24, 26, 35, 36, 40, PM-394, PM-494, M 1, 2, 2B, 4, 4B, 6, 6B, Californian, Arizona, Eager-Beaver, 10, 12, 12 A/S, 14 AVS, 16 E, 170, 374, 384, 394, 484, 494, 735, 930, 935, C 180, EM-8							
Mac110, 120, 130, 140, 160, PM300, PM310, PM320, PM330, PM340, PM360, PM364, PM370, PM380, PM394, PM470, PM474, PM480, PM484, PM494, PM530, PM538, PM540, 832, 833, 835, 836, 838, 839, 930, Euromac S32, S33, S34, S36, S40, S41, ELECTR							
PARKSIDE KSE1435, KSE1640, EKS1650, 1700PKS40, 2000							
PARTNER P1535, P1550, 1640, P1850, P538, 538E							
RYOBI 35B, CS 36C, CS 41, CSE 330, CSE 3330, CSE 385CB, HC 31, HCS 31, HC 36, HC 41, CS 1530, CS 1535, CS 1540 CS 41, HC 41, CS1540							
STARK-SYMPRA-SYMPRATEC 1416, 1500, 1600, 1616, 1440, 14840, 16840							
STIHL 009, 010, 011, 012, 015, 018C, 019, 020, 020/T, 021, 023, 023C, 023L, 025, 025C, E 10, E 14, E 20, E 140, E 160, E 180, E 180C, E 220, E 220C, MS 180C, MS 190, MS 190T, MS 200, MS 200T, MS 210, MS 211, MS 230, MS 250, MSE 160, MSE 180, MSE 200, AVH-Elektronik							
TALON AC2101, AC2105, AC2109, AC2111, AC3100							

Saw chains classified by bar length kwb Part no./ Manufacturer





Manufacturer/machine model	Guide bar length cm	Spacing 	Drive links 	Drive link width 		kwb quick reference number	Part-No.
ALDI							
Kingkraft KSI2000-40, KS1500B, EKS1700, EKS1750							
ALKO							
KE 40-16, KE 1750, KSB 40/40 II, BKS 40/40II							
E 25A, E 1200 S, E 125, E 1400, E 1500, EK 25 A, KB 3500, KB 4000, KB 4001, KB 4500, KB 4501, KE 14, KE 16, KE 18, KSB 1450, P11, P12, 2000, 2300, 3000, KS, KSB, Elektro							
ALPINA-CASTOR							
EL140, EL160, EL170, 300, 330, 380, 423, 432, 438, CP34S, P34, P34S, P350, P380, P438, PR350, PR370, Euro35, Euro40, Euro45, KS300, KS350, CX35, CX40, CX 45, Energie 1.6, E1.8, Jolly40 Garden Ranger							
BLACK & DECKER							
CS30, CS35, D35KS, D40KS, DN301, DN302, DN400, DN401, DN402, DN402/B, DN404, DN404/B, DN404-TypH2, DN410, DN412, DN416, DN 430, GK30, GK40, GK100/110, GK120, GK130, GK300, GK31, GK310, GK320, GK321, GK322, GK330, GK331, GK3300, GK35, GK42, GK43, GK430, GK425, GK435, GK440, GK535, GK540, 5400, 8308, 8310, 8312, 8314, GK1300K, GK1330, GK1440, GK1530, GK1630T, GK1430, GK1435, GK1630 XC, GK1635, GK1830, Pro40							
GK1640T, GK1640TG, GK1640XC, GK1740X, GK2040T, GT1640TX							
BULLKRAFT							
KS 400, KS 400/2, KS 400/3							
CASTEL GARDEN							
XC 36P, XC 37, XC 18EL, XC 20EL							
CASTORAMA							
Cast TPE 40							
DOLMAR							
33, 40, 100, 100s, 102, 103, 104, 105, 108, 270, 271, 275, 285, 290, 295, ES 3, ES 6A, ES 30, ES 32A, ES 33A, ES 35, ES 37A, ES 38A, ES 40A (ab 09/01), ES 41A, ES 42A, ES 140, ES 151A, ES 152A, ES 153A, ES 160, ES 160A, ES 161A, ES 162A, ES 163A, ES 171A, ES 172A, ES 173A, ES 183A, ES 1600, ES 2030A, ES 2035A, ES 2040A, ES 2135A, ES 2140A, PS 33, PS 34, PS 36, PS 41, PS 45 (1,3mm), PS 39, PS 330, PS 340, PS 341, PS 342, PS 344, PS 350, PS 390, PS 400, PS 401, PS 3300TH, PS 3410, PS 3500TH, PS 3400TH, PS 3410TH	40	3/8"	56	1,3	ø 4,0	A56	640356
EINHELL							
BG-EC 2240, RG-EC 2240 MG, REC 2240 TC, GH-EC 2040							
FARM U. GARTEN							
160EL, 165EL, 170EL, 180EL, 360P, 370P, 390P							
GRIZZLY							
BKS 35-14, BKS 35-38, BKS 35-40, BKS 38-14, BKS 38-16, PKS 360/390, EKS 1600, EKS 1700-40, EKS 1800, EKS 400I, EKS 400TL, EKS 2000, P390, BKS 350, BKS 400, KSI 2000							
HOMELITE							
2014B, 20AV, HCS 3435BA, ECW 1641							
HERKULES							
1/41							
HUSQUARNA							
Husky 35, Hisky 36, Husky 37, Husky 41, 315, 316, 318, 320 Electric							
IKRA							
A104P+S, A204S, A205B, FA12, FA14, KS12, H014S, KS14, KS30ST, KS400, KS1200B, KS1250B, KS1300, Shark1300, KS1400, KS1400A,KS1400B, KS1500, KS1600, KS2000, 1200KS, Shark PE1400, Sup-Pro 1500, KS1500T, KS 1500TS, KS1700DL, KSE2000, EKS30, EKS35, EKS40, EKS1500-35, EKS1400, EKS1600, EKS1650, EKS1700, EKS1800, EKS2000, BKS301, BKS402, BKS4135, PKS40							
KS1400B-40, KS1500B-40, KSB3940, MKS 40, Peifi Cutter, SEK 618							
JONSERED							
2036, 2040, 2033, 370, 380, CS2115EL, CS2120EL, CS2137							
KINGCRAFT							
KS1500B							

Manufacturer/machine model	Guide bar length cm	Spacing 	Drive links 	Drive link width 		kwb quick reference number	Part-No.
MCCULLOCH							
Electramac 16-EE, ES 30, 22, 24, 26, 35, 36, 40, PM-394, PM-494, M 1, 2, 2B, 4, 4B, 6, 6B, Californian, Arizona, Eager-Beaver, 10, 12, 12 A/S, 14 AVS, 16 E, 170, 374, 384, 394, 484, 494, 735, 930, 935, C 180, EM-8							
MacCat 440, 441, 442							
OBI-DIANA							
1400-40KS							
OLEO MAC OLYM.							
936, 940C, E140							
PARKSIDE							
KSE1435, KSE1640, EKS1650, 1700PKS40, 2000							
PARTNER							
1400E, 1500-EL, 1601, 1602, 1612, 1613, 1614, 1616, 1618							
330, 335, 340, 345, 350, 351, 357, 360, 365, 370, 371, 385, 389, 390, 405, P-420, P 740, P 842, P842CC							
PEUGEOT							
TLS 1630, TRC 1630, TLS 1635, TLS 1635A, TRC 1635, TLS 1640, TRC 1640, EKS1740	40	3/8"	56	1,3	ø 4,0	A56	640356
POULAN							
2050, 2150, 2250, 2450, 2550, Woodshark, Pro4016							
RYOBI							
CSN 410, ECW 1641, HCS 340BA							
SOLO							
662, KSB 2640							
STAYER							
SEC 40							
STIGA							
SE 1.8, SE180, SE 190, SE 200Q, SP 370, SP 410, SPR 350							
DPC-1316							
TOPCRAFT							
KSI2000-40, EKS1700, EKS1750, EKS1800							
TURBO SILENT							
BKS4041							
AEG							
KS 40							
ALDI							
TopCraft EKS 1700, EKS 1800, EKS 1750							
ALKO							
KE1000, 3000, 3500, 3500Vario, 4000, KE40-18, KE1600/40, KE1750/40, KE2200/40							
E 25A, E 1200 S, E 125, E 1400, E 1500, EK 25 A, KB 3500, KB 4000, KB 4001, KB 4500, KB 4501, KE 14, KE 16, KE 18, KSB 1450, P11, P12, 2000, 2300, 3000, KS, KSB, Elektro							
ALPINA-CASTOR							
A10, A10E, A12, A12E, A14, A14E, E100, E120, E130, E150, E160, E170, KS1400B, KS1500B, P360, P390							
CP55, CP65, CP66, Prof.55, Prof.60, 540, 600, P700, 800							
ASGATEC							
1400, 1600, 1801, 1840, 2001, 2040							
ATIKA							
KS 2001/40	40	3/8"	57	1,3	ø 4,0	A57	640357
BLACK & DECKER							
GK1940T, GK 2240T							
BOSCH							
AES 35, AKE 30B, AKE 30E, AKE 35B, AKE 40B, AKE 40-16S, AKE 40-19Pro, GKE 40B, GKE 40BC, GKE 40 BCE, PKE 10B, PKE 25, PKE 30B, PKE 35B, PKE 40, PKE 40B, PKE 40BC, PKE 1350B, 1586.8							
BUDGET							
BEKS 1840, BKS 401, BKS 402							
CMI							
KS1840, 2040 KS							
DEFORT							
DEC-1645N, DEC-2045N							





Saw chains classified by bar length kwb Part no./ Manufacturer





Manufacturer/machine model	Guide bar length cm	Spacing 	Drive links 	Drive link width 		kwb quick reference number	Part-No.
DYNAMAC							
DY 36, DY 19E							
ECHO							
CS 3400, CS 3450, CS 4400, CS 1550FT, CS 1850FT							
EFCO							
136, 140							
117E, 119E							
EINHELL							
41, 40A, BG-EC-840TC, BG-EC 1840, BG-EC 1840 TC, BG-EC 2040S, BG-EC 2240, BG-PC 4040, CS 38,EKS 1840, EKS 2040, EKS 2040/1P, 2040P, KS 1800-40, KSE 1435, KSE 1635, KSE 1640,KSE 1740, KSE 2000, KSE 3000, KSE 4000, MKS 34, MKS 40AV, NKS 2000, PCS 3840, PES 1435, PES 1540, PES 1640, PES 1740, PES 1840, PES 40/3, PES 40S, PES 4000, PKS 1840, PKS 2000, PKS 2040, PKS 2040 WK, PKS 40/1AV, RBK 4040, REK 1840, RG-EC 2040, RG-EC 2240, RG-EC 2240 TC, RPC 4640, RPC 2040, REC 1840, REK 1840/1, REK 184, REK 2048, Turbo-Silent							
FLEURELLE							
KS1435, KS1640, KSE1640, KSE1845, KSE2040-1, KSB2035, KSB2640							
GARDENA							
CST 4020-X							
GRIZZLY							
BKS 35-14, BKS 38-14, BKS 38-16, EKS 400I, EKS 400TL, EKS 1600, EKS 1800, EKS 1800-40, EKS 1850, EKS 2000, EKS 2000-6, EKS 2000-6QT, P390, BKS 350, BKS 400, KSI 2000							
GÜDE							
KS 400E							
HANSEATIC							
1840 KS, 2040 KS	40	3/8"	57	1,3		A57	640357
HERKULES							
18/41							
HITACHI							
CS 35B							
HOMELITE							
CSP 4016							
HURRICANE							
PS 200-40E							
IKRA							
A104P+S, A204S, A205B, FA12, FA14, KS12, H014S, KS14, KS30ST, KS400, KS1200B, KS1250B, KS1300, Shark1300, KS1400, KS1400A,KS1400B, KS1500, KS1600, KS2000, 1200KS, Shark PE1400, Sup-Pro 1500, KS1500T, KS 1500TS, KS1700DL, KSE2000, EKS30, EKS35, EKS40, EKS1500-35, EKS1400, EKS1600, EKS1650, EKS1700, EKS1800, EKS2000, BKS301, BKS402, BKS4135, PKS40							
KSI1600-35, KSI1600-40, KSI1800-40, KSE2000-35, KSE2000-40, KSE2000-45, KS1500TS							
KS1400T, KS1500T							
KS1600T							
IKRA							
KS1640, BKS401, KSI2000-40, SWING1840KS, 2140KSE, Variolux, SWING2040KS, CMI2040S, Hanseatic 1840KSM, KSE2040, KS1600T-40, KS2000TF, KS2000TS, KS1600TF-40, 1640Shark, KF1800TF-40, KF1800TS-40, KS1400T/TS, KS1640, KS1800TF/TS, PKS40, KS2000TF/TS							
KINGCRAFT							
EKS1650, KSI2000-40							
KOMATSU ZENOAH							
G31AVS, G310TS, G3100, G3200, G3300, G380AVS, G3800, G2800AVS							

... always the appropriate accessories for your machine!





Manufacturer/machine model	Guide bar length cm	Spacing 	Drive links 	Drive link width 		kwb quick reference number	Part-No.
MAKITA							
Electric 5011B, Electric 5012B, Electric, 5014-NB, Electric 5016-B, Electric 5016-NB							
DCS 33, DCS 34, DCS 300, DCS 330, DCS 330S, DCS 330TH, DCS 340, DCS 341, DCS 342, DCS 344, DCS 350, DCS 380, DCS 390, DCS 400, DCS 401, DCS 3300TH, DCS 3400TH, DCS 3401TH, DCS 3500, DCS 3501, DCS 4610, DES 350, DES 400, UC 300, UC 3000, UC 3000A, UC 3001A, UC 3003A, UC 3500, UC 3500A, UC 3501A, UC 3503A, UC 4000, UC 4000A, UC 4001A, UC 4003A, 5014B, 5016B, 5016NB							
ES 2000-400, EK 2000-400							
MATRIX							
ES2000-400, EK2000-400							
MAX BAHR							
Bahr 2000, Bonus 1800, EKS 1800-40, KSI 2000-40							
METABO							
KT 1441, KT1440							
OBI-CMI							
CMI 2040KS/KSI, 2040KSS, BKS45, KS 1840/1, KS 2000							
O.K.							
EKS 1840							
OLEO MAC OLYM.							
935, 936, 940							
OPEM							
140Z, 142Z							
POULAN							
25A, Micro 25, S 25 CVA, S 25D, S 25DA, 1800, 2000, 2300AV, 2300CVA, P 600							
PROVIL							
PVKS 20000E, PVKS 2000/1E							
RYOBI	40	3/8"	57	1,3		A57	640357
HCS 3435BA							
SHINDAIWA-SDK-ISEKI							
140, 160, 285s, 300s, 305s, 305AVZ, 340, 345, 346, 350, 352s, 355, 357s, 360, 377, 391, 395, A-090, 102, 103, 104, 105, 107, 110, 110P, 113L+P, 117P, 100, E 150, 315, YB 301, YB 401, A 090B, A 100C, A 102, A 150B							
1600 ES							
SHINGU							
SP 3400							
SKIL							
1600HE, 1601HE, 1602HE, 1603H, 1604H, 1606H, 1610U, 1612U, 1616U, 1620U, 1634U, 1636U, 1712U							
SOLO							
613, 614, 620, 630, 633, 635, 635ECO, 636, 637, 640, 643							
SWING							
1840KS, 2040KS							
TAS-TANAKA							
290, 300, ECS 320, ECS 330, ECS 3301, ECS 3351, ECS 3401, TCS 3301S, TCS 3401							
TOPCRAFT							
KSI2000-40, EKS1700, EKS1750, EKS1800							
TURBO SILENT							
EKS2040							
UNIROPA							
KSE2035, KSI1800-35, KSE2040, KSI20-40							
VARIOLUX							
2135KSE, 2140KSE, 2335BKS, 2340BKS							
ZENOAH							
G 380AV, G 380AVS, G 3800AVS							

Saw chains classified by bar length kwb Part no./ Manufacturer





Manufacturer/machine model	Guide bar length cm	Spacing 	Drive links 	Drive link width 		kwb quick reference number	Part-No.
ALPINA CASTOR PS 34, PS 34S SHINDAIWA-SDK-ISEKI SBA-P230 STIHL 009, 017, 018, 019/T, 23L, E 140, MS 170, MS 171C, MS 180, MS 181, MS 190T, MS 192, MS 192T, E14, MSE 140, HT 70/75 TAS-TANAKA TPS 2501, TPS 2501S, TPS 2510, RPS 200H	30	3/8"	44	1,1	ø 4,8	C44	640644
EFCO 115E OLEO MAC OLYM. E 1500 STIHL 009, 017, 018, 019/T, 23L, E 140, MS 170, MS 171C, MS 180, MS 181, MS 190T, MS 192, MS 192T, E14, MSE 140, HT 70/75	35	3/8"	50	1,1	ø 4,8	C50	640650
BOSCH AKE 30-17S, AKE 35, AKE 35-17S, AKE 35-18S, AKE 35-19S, AKE 40-17S DOLMAR ES-5A, ES 36A, ES 37A, ES 38A, PS 34 MAKITA EL-UC 210R, DCS 34, UC 3010A, UC 3510U, DCS3400, DCS 3410, UC 4010A PARTNER 1436, 1641 POULAN E 5300 SOLO 633, 636-Microlite	35	3/8"	52	1,1	ø 4,0	C52	640652
ALPINA-CASTOR P410 CASTEL GARDEN XC 41 DOLMAR PS-410, PS-411, PS-420, PS420C DYNAMAC DY 41 EFCO 138, 141 HOMELITE i3850B, D 4550B, D 3850BC, EZ-AO-130/150/290/340, XL-76/100/250, VI-123/125, VISuper Mini HUSQUARNA 33, 36, 40, 41, 42, 44,45, 49, 51, 55, 131, 136, 141, EL1200, E1400, E1600, EL16, 136, 137 e-serie, 140, 141, 142 e-serie, 340, 345, 346, 350, 351, 242XP JONSERED 2016, 2036, 2040, 2041, 2045, 2050, 2054, 2055, CS2147, CS2152 MAKITA DCS 410, DCS 411, DCS 4301, DCS 440, DCS 441, DCS 430, DCS 520, DCS 4300i, DCS 5200i MAFELL EKS400S MCCULLOCH PM 3500, 4000, 400-P, 4500, 4700, 4900, 5000, Titan 35+40, Logger-Kit, 3500, 400P, T 35, T 40, PM 38, 40-46, T 46, T 48, ProMac 10-42, ProMac 10-49Pro, ProMac 40, ProMac 40II, ProMac 46, ProMac 46II, Timber NAUTEC 138	38	.325	64	1,3	ø 4,8	D64	640864

Manufacturer/machine model	Guide bar length cm	Spacing 	Drive links 	Drive link width 		kwb quick reference number	Part-No.
OLEO MAC OLYM. 240, E 170, E170F 945, 950, 938, 941	38	.325	64	1,3	ø 4,8	D64	640864
PARTNER P-21, 26, 28, 360, 365, 400, 405, 410, 411, 450, 460, P461, P461II, 462, P470, 500, P510, 511, 540, 543, 1074, 5000, EL 1450, EL 1650							
POULAN 2800, 2900, 3300, 3350							
SHINDAIWA-SDK-ISEKI 360, 366, 370, 394, 400, 415, 416, 420, 450, 451, 457, 488, 495, 500, 506, 510, 560, 601, 691, A-180B, YB 501, YB 601, YB 701							
SOLO 634, 639, 645							
STIGA SP 410, SP 370							
ZENOAH G 415AVS-16							
STIHL 024/WB, 025, 026/C/W/CW/WB/WVH, 028, 028/S/WB/AV/EQ, MS 240, MS 260, MS 270, MS 280							
BOSCH 1535							
DOLMAR 105, 108, 109, 110, 110i, 111, 112, 113, 113CA, 114, 115, 115i, 115iH, 116, 116si, 117, 118, 119, 120, 120Si, 120super, 219, PS43, PS52, PS6000iH, PS6000i, PS6800i, PS6800iH, PS9000, PS6000, PS6800 PS 460(3/8"), PS 500(3/8"), PS 52, PS 5000(3/8") PS5000, PS6400, PS7300, PS7900, PSW6400H, PS7300H, PS79004, 153, 152, 144, PS 9010							
HUSQUARNA 61, 75, 77, 162, 163, 181, 246, 262, 263, 266, 268, 272, 280, 281, 285, 286, 288, 289, 298, 365, 371, 380, 480 (XP/XPG), 61, 65, 66, 1100, 2100, 2100XP, 2101, 25XP, 245XPG, 254XP, 254XPG, 27, 262, 264, 288XPG, 338XPT, 334T, 365, 372XP, 385XP, 394XPG, 395XP, 395XPG, 3120XP, 55							
JONSERED CS2156, CS2159, CS2163, CS2165, CS2171							
MAKITA DCS 43, DCS 52, DCS 430, DCS 431, DCS 460, DCS 461, DCS 480, DCS 500, DCS 501, DCS 520, DCS 520i, DCS 4300, DCS 4600S, DCS 4600SH, DCS 5000, DCS 5001, DCS 5000H, DCS 5200i, DCS 6600, DCS 6000i, DCS 6400, DCS 6800, DCS 6800i, DCS 7300, DCS 7900							
MCCULLOCH Mac 950, 951, 955, 960, 961, 970, Pro Mac 51, 55, 60, 61, 72, Titan 51, 61, Topso							
OLEO MAC OLYM. 250, 250A, 251, 251B, 251S, 252, 254, 260, 261, 264, 271, 272, 280, 284, 350, 350S, 355, 460, 480, 481, 482, 484, E 300, OM-E 300, 956, 962, 970, 980							
PARTNER P 500, 605, P 5000							
PARTNER 550, 650, 660, 1633-B, F 55, F 65, P-55, 65, 70, 85, 7000, R-11, 12, 14, R-16, 17, 18, 19, 20, 21, R-22, 30, 40, 417, 418, R-420, 421,422, 435, R-440, 522, 523, S-50, 55, 65, 660, P-7700							
SOLO 662, 670, 680, 690							
STIHL 029, 030, 031, 032, 034/S, 036/W/WVH, 036QS, 038, 039, 041, 042, 044, 045, 046, 048, 056, 064, E-10, E-16, E-20, E-220, MS 290, MS 310, MS 360/C, MS 390, MS 440/C, MS 460/C, MS 660							
40	3/8"	60	1,6	ø 4,8	M60	641860	





Saw chains classified by manufacturer

Manufacturer/machine model	Guide bar length cm	Spacing 	Drive links 	Drive link width 		kwb quick reference number	Part-No.
AEG							
KS 30	30	3/8"	45	1,3	∅ 4,0	A45	640345
KSE 35, KS 35	35	3/8"	52	1,3	∅ 4,0	A52	640352
KS 40	40	3/8"	57	1,3	∅ 4,0	A57	640357
ALDI							
	35	3/8"	49	1,3	∅ 4,0	A49	640349
	40	3/8"	55	1,3	∅ 4,0	A55	640355
Kingkraft KSI2000-40, KS1500B, EKS1700, EKS1750	40	3/8"	56	1,3	∅ 4,0	A56	640356
TopCraft EKS 1700, EKS 1800, EKS 1750	40	3/8"	57	1,3	∅ 4,0	A57	640357
ALKO							
Hobby 320, E135, E1200E, 1400E, 1500E	30	3/8"	44	1,3	∅ 4,0	A44	640344
KB350, KB450, 3500, 4000, 4500, KB3501, 4001, 5001	30	3/8"	44	1,3	∅ 4,0	A44	640344
	35	3/8"	49	1,3	∅ 4,0	A49	640349
KE1800/35, KE4000Vario	35	3/8"	50	1,3	∅ 4,0	A56	640356
BKS 35/35 II, KE 2000/35, KE40-16/11, KE1400/35, KE1600/35	35	3/8"	52	1,3	∅ 4,0	A52	640352
KE 40-16, KE 1750, KSB 40/40 II, BKS 40/40II	40	3/8"	56	1,3	∅ 4,0	A56	640326
KE1000, 3000, 3500, 3500Vario, 4000, KE40-18, KE1600/40, KE1750/40, KE2200/40	40	3/8"	57	1,3	∅ 4,0	A57	640357
	30	3/8"	44	1,3	∅ 4,0	A44	640344
E 25A, E 1200 S, E 125, E 1400, E 1500, EK 25 A, KB 3500, KB 4000, KB 4001, KB 4500, KB 4501, KE 14, KE 16, KE 18, KSB 1450, P11, P12, 2000, 2300, 3000, KS, KSB, Elektro	30	3/8"	45	1,3	∅ 4,0	A45	640345
	35	3/8"	50	1,3	∅ 4,0	A50	640350
	35	3/8"	52	1,3	∅ 4,0	A52	640352
	40	3/8"	56	1,3	∅ 4,0	A56	640356
	40	3/8"	57	1,3	∅ 4,0	A57	640357
ALPINA-CASTOR							
PS 34, PS 34S	30	3/8"	44	1,1	∅ 4,8	C44	640644
	30	3/8"	45	1,3	∅ 4,0	A45	640345
A10, A10E, A12, A12E, A14, A14E, E100, E120, E130, E150, E160, E170, KS1400B, KS1500B, P360, P390	35	3/8"	50	1,3	∅ 4,0	A50	640350
	35	3/8"	52	1,3	∅ 4,0	A52	640352
	40	3/8"	57	1,3	∅ 4,0	A57	640357
EL140, EL160, EL170, 300, 330, 380, 423, 432, 438, CP34S, P34, P34S, P350, P380, P438, PR350, PR370, Euro35, Euro40, Euro45, KS300, KS350, CX35, CX40, CX 45, Energie 1.6, E1.8, Jolly40 Garden Ranger	30	3/8"	44	1,3	∅ 4,0	A44	640344
	35	3/8"	49	1,3	∅ 4,0	A49	640349
	35	3/8"	50	1,3	∅ 4,0	A50	640350
	40	3/8"	55	1,3	∅ 4,0	A55	640355
	40	3/8"	56	1,3	∅ 4,0	A56	640356
CP55, CP65, CP66, Prof.55, Prof.60, 540, 600, P700, 800	40	3/8"	57	1,3	∅ 4,0	A57	640357
P410	38	.325	64	1,3	∅ 4,8	D64	640864
ASGATEC							
1400, 1600, 1801, 1840, 2001, 2040	35	3/8"	52	1,3	∅ 4,0	A52	640352
	40	3/8"	57	1,3	∅ 4,0	A57	640357
ATIKA							
KS 2001/40	40	3/8"	57	1,3	∅ 4,0	A57	640357
BLACK & DECKER							
CS30, CS35, D35KS, D40KS, DN301, DN302, DN400, DN401, DN402, DN402/B, DN404, DN404/B, DN404-TypH2, DN410, DN412, DN416, DN 430, GK30, GK40, GK100/110, GK120, GK130, GK300, GK31, GK310, GK320, GK321, GK322, GK330, GK331, GK3300, GK35, GK42, GK43, GK430, GK425, GK435, GK440, GK535, GK540, 5400, 8308, 8310, 8312, 8314, GK1300K, GK1330, GK1440, GK1530, GK1630T, GK1430, GK1435, GK1630 XC, GK1635, GK1830, Pro40	30	3/8"	44	1,3	∅ 4,0	A44	640344
	30	3/8"	45	1,3	∅ 4,0	A45	640345
GK1430, GK1300	35	3/8"	49	1,3	∅ 4,0	A49	640349
	40	3/8"	55	1,3	∅ 4,0	A55	640355
	40	3/8"	56	1,3	∅ 4,0	A56	640356
GK1430, GK1300	30	3/8"	44	1,3	∅ 4,0	A44	640344
GK1635TX, GK1635TG, GK1435	35	3/8"	49	1,3	∅ 4,0	A49	640349
GK1640T, GK1640TG, GK1640XC, GK1740X, GK2040T, GT1640TX	40	3/8"	56	1,3	∅ 4,0	A56	640356
L10	30	3/8"	45	1,3	∅ 4,0	A45	640345
	35	3/8"	49	1,3	∅ 4,0	A49	640349
GK1940T, GK 2240T	40	3/8"	57	1,3	∅ 4,0	A57	640357





... always the appropriate accessories for your machine!

Manufacturer/machine model	Guide bar length cm	Spacing 	Drive links 	Drive link width 		kwb quick reference number	Part-No.
BEL PICKPINE							
16	30	3/8"	44	1,3	∅ 4,0	A44	640344
34, 16	35	3/8"	49	1,3	∅ 4,0	A49	640349
BLITZ							
B 300, B 304, B 34, E 140F	30	3/8"	44	1,3	∅ 4,0	A44	640344
B 35D, B 38	35	3/8"	49	1,3	∅ 4,0	A49	640349
BONUS							
KSB 35	35	3/8"	49	1,3	∅ 4,0	A49	640349
KSE 2000 S	40	3/8"	55	1,3	∅ 4,0	A55	640355
BOSCH							
AKE 30, AKE 30-17S, AKE 30-18S	30	3/8"	45	1,1	∅ 4,8	C45	640645
AKE 30-17S, AKE 35, AKE 35-17S, AKE 35-18S, AKE 35-19S, AKE 40-17S	35	3/8"	52	1,1	∅ 4,0	C52	640652
EKS 1535, 1540, KS 300	30	3/8"	44	1,3	∅ 4,0	A44	640344
AES 35, AKE 30B, AKE 30E, AKE 30-19Pro, AKE 30-16S, AKE 35B, AKE 40B, AKE 300B, PKE 10B, PKE 25, PKE 30 PowerSharp, PKE 30B, PKE 35B, PKE 40B, PKE 40BC, PKE 1350B, GKE 35BC, 1586	30	3/8"	45	1,3	∅ 4,0	A45	640345
AES 35, AKE 30B, AKE 30E, AKE 35B, AKE 35-16S, AKE 35-17, AKE 35-19Pro, AKE 40B, AKE 350B, GKE 35, GKE 35BC, GKE 35 BCE, PKE 10B, PKE 25, PKE 30B, PKE 35 PowerSharp, PKE 35B, PKE 40B, PKE 40BC, PKE 1350B, 1586.7	35	3/8"	52	1,3	∅ 4,0	A52	640352
AES 35, AKE 30B, AKE 30E, AKE 35B, AKE 40B, AKE 40-16S, AKE 40-19Pro, GKE 40B, GKE 40BC, GKE 40 BCE, PKE 10B, PKE 25, PKE 30B, PKE 35B, PKE 40, PKE 40B, PKE 40BC, PKE 1350B, 1586.8	40	3/8"	57	1,3	∅ 4,0	A57	640357
1535	38	3/8"	56	1,5	∅ 4,8	L56	641756
BUDGET							
BKS 301	30	3/8"	45	1,3	∅ 4,0	A45	640345
BBKS 1235	35	3/8"	52	1,3	∅ 4,0	A52	640352
BKS 402	40	3/8"	55	1,3	∅ 4,0	A55	640355
BEKS 1840, BKS 401, BKS 402	40	3/8"	57	1,3	∅ 4,0	A57	640357
BULLKRAFT							
KSE 30, KS 300, KSE 1300B, GK 30, KSM 25, 300 S	30	3/8"	44	1,3	∅ 4,0	A44	640344
KSE 1300B, BES 1300B, KS 350, KS 350/2	35	3/8"	49	1,3	∅ 4,0	A49	640349
KS 40S, KS 400S, KSE 1300B, KSM 40	40	3/8"	55	1,3	∅ 4,0	A55	640355
KS 350, KS 350/2, KS 400, KS 400/2	35	3/8"	50	1,3	∅ 4,0	A50	640350
KS 400, KS 400/2; KS 400/3	40	3/8"	56	1,3	∅ 4,0	A56	640356
CASTEL GARDEN							
XC 35P	30	3/8"	44	1,3	∅ 4,0	A44	640344
XC 18EL, XC 20EL, XC 35P, XC 36, XC 37	35	3/8"	50	1,3	∅ 4,0	A50	640350
XC 36P, XC 37, XC 18EL, XC 20EL	40	3/8"	56	1,3	∅ 4,0	A56	640356
XC 41	38	.325	64	1,3	∅ 4,8	D64	640864
CASTORAMA							
Cast TPE 40	40	3/8"	56	1,3	∅ 4,0	A56	640356
CMI							
KS1840, 2040 KS	40	3/8"	57	1,3	∅ 4,0	A57	640357
DEFORT							
DEC-1645N, DEC-2045N	40	3/8"	57	1,3	∅ 4,0	A57	640357
DPC-1316	40	3/8"	57	1,3	∅ 4,0	A57	640357
DOLMAR							
ES-5A, ES 36A, ES 37A, ES 38A, PS 34	35	3/8"	52	1,1	∅ 4,0	C52	640652
	30	3/8"	45	1,3	∅ 4,0	A45	640345
101, 200, 201, 260, 290	35	3/8"	50	1,3	∅ 4,0	A50	640350
	35	3/8"	52	1,3	∅ 4,0	A52	640352





Saw chains classified by manufacturer





Manufacturer/machine model	Guide bar length cm	Spacing 	Drive links 	Drive link width 		kwb quick reference number	Part-No.
DOLMAR							
33, 40, 100, 100s, 102, 103, 104, 105, 108, 270, 271, 275, 285, 290, 295, ES 3, ES 6A, ES 30, ES 32A, ES 33A, ES 35, ES 37A, ES 38A, ES 40A (ab 09/01), ES 41A, ES 42A, ES 140, ES 151A, ES 152A, ES 153A, ES 160, ES 160A, ES 161A, ES 162A, ES 163A, ES 171A, ES 172A, ES 173A, ES 183A, ES 1600, ES 2030A, ES 2035A, ES 2040A, ES 2135A, ES 2140A, PS 33, PS 34, PS 36, PS 41, PS 45 (1,3mm), PS 39, PS 330, PS 340, PS 341, PS 342, PS 344, PS 350, PS 390, PS 400, PS 401, PS 3300TH, PS 3410, PS 3500TH, PS 3400TH, PS 3410TH	30	3/8"	46	1,3	ø 4,0	A46	640346
	35	3/8"	52	1,3	ø 4,0	A52	640352
	40	3/8"	56	1,3	ø 4,0	A56	640356
101 PowerSharp	30	3/8"	45	1,3	ø 4,0	A45	640345
104 PowerSharp	35	3/8"	52	1,3	ø 4,0	A52	640352
PS-410, PS-411, PS-420, PS420C	38	.325	64	1,3	ø 4,8	D64	640864
105, 108, 109, 110, 110i, 111, 112, 113, 113CA, 114, 115, 115i, 115iH, 116, 116si, 117, 118, 119, 120, 120Si, 120super, 219, PS43, PS52, PS6000iH, PS6000i, PS6800i, PS6800iH, PS9000, PS6000, PS6800	38	3/8"	56	1,5	ø 4,8	L56	641756
PS 460(3/8"), PS 500(3/8"), PS 52, PS 5000(3/8")	38	3/8"	56	1,5	ø 4,8	L56	641756
PS5000, PS6400, PS7300, PS7900, PSW6400H, PS7300H, PS79004, 153, 152, 144, PS 9010	38	3/8"	56	1,5	ø 4,8	L56	641756
	40	3/8"	60	1,5	ø 4,8	L60	641760
DYNAMAC							
30F, E 140F	30	3/8"	44	1,3	ø 4,0	A44	640344
35F	35	3/8"	49	1,3	ø 4,0	A49	640349
DY 36, DY 19E	40	3/8"	57	1,3	ø 4,0	A57	640357
DY 41	38	.325	64	1,3	ø 4,8	D64	640865
ECHO							
CS 200E, CS 280E, CS 280EVL, CS 290EVL, CS 300, CS 302, CS 320, CS 3000, CS 3050	30	3/8"	45	1,3	ø 4,0	A45	640345
CS 2700ES, CS 280EG, CS 330EVL, CS 350T, CS 3050, CS 3400, CS 3500	35	3/8"	53	1,3	ø 4,0	A53	640353
	35	3/8"	52	1,3	ø 4,0	A52	640352
	40	3/8"	57	1,3	ø 4,0	A57	640357
EFCO							
115E	35	3/8"	50	1,1	ø 4,8	C50	640650
131	30	3/8"	45	1,3	ø 4,0	A45	640345
	30	3/8"	45	1,3	ø 4,0	A45	640345
136, 140	35	3/8"	52	1,3	ø 4,0	A52	640352
	40	3/8"	57	1,3	ø 4,0	A57	640357
	30	3/8"	44	1,3	ø 4,0	A44	640344
114E, 134, 135, 116	35	3/8"	49	1,3	ø 4,0	A49	640349
EFCO							
117E, 119E	35	3/8"	50	1,3	ø 4,0	A50	640350
	40	3/8"	57	1,3	ø 4,0	A57	640357
138, 141	38	.325	64	1,3	ø 4,8	D64	640864
EINHELL							
CS 280, EKS 35, EKS 35-1, MKS 30, MKS 34, PE 34/2, PE 35/3ZS, PES 2000, PES 30/2, PES 30-2, PES 34/3, PES 34/2, PES 34/3, PES 35, PES 35/2TS, PES 35-2, PES 35-3, PES 40S, PKS 35-1AV, PES 40/3, PES 1435, PES 1540, PES 1640, PES 1540, PES 1640, PES 1840, KSE 1435, KSE 1635, KSE 1640, KSE 2000, KSE 3000, KSE 4000	30	3/8"	45	1,3	ø 4,0	A45	640345
AC 31114, BKS 38/35, MKS 35, PBK 35/35	35	3/8"	49	1,3	ø 4,0	A49	640349
MKS 35, PES 1435	35	3/8"	50	1,3	ø 4,0	A50	640350
36GS, KSE 1435, KSE 1635, PE 35/3TS, PES 1435, PES 3000, PES 4000, PKS 1635, PKS 34/1AV, P35, RBK 3735, BG-PC 1235, BG-PC 3735, GH-EC 1835, RPC 3835, PES 40/3, PES 1435, PES 1540, PES 1640, PES 1540, PES 1640, PES 1840, KSE 1435, KSE 1635, KSE 1640, KSE 2000, KSE 3000, KSE 4000	35	3/8"	52	1,3	ø 4,0	A52	640352
PES 1840, REK 2040WK, PES 1540, PES 1640, BG-PC 4040	40	3/8"	55	1,3	ø 4,0	A55	640355
BG-EC 2240, RG-EC 2240 MG, REC 2240 TC, GH-EC 2040	40	3/8"	56	1,3	ø 4,0	A56	640356

... always the appropriate accessories for your machine!





Manufacturer/machine model	Guide bar length cm	Spacing 	Drive links 	Drive link width 		kwb quick reference number	Part-No.
EINHELL							
41, 40A, BG-EC-840TC, BG-EC 1840, BG-EC 1840 TC, BG-EC 2040S, BG-EC 2240, BG-PC 4040, CS 38, EKS 1840, EKS 2040, EKS 2040/1P, 2040P, KS 1800-40, KSE 1435, KSE 1635, KSE 1640, KSE 1740, KSE 2000, KSE 3000, KSE 4000, MKS 34, MKS 40AV, NKS 2000, PCS 3840, PES 1435, PES 1540, PES 1640, PES 1740, PES 1840, PES 40/3, PES 40S, PES 4000, PKS 1840, PKS 2000, PKS 2040, PKS 2040 WK, PKS 40/1AV, RBK 4040, REK 1840, RG-EC 2040, RG-EC 2240, RG-EC 2240 TC, RPC 4640, RPC 2040, REC 1840, REK 1840/1, REK 184, REK 2048, Turbo-Silent	40	3/8"	57	1,3	ø 4,0	A57	640357
EK							
1535, Migros E 35, KSE 1435	35	3/8"	52	1,3	ø 4,0	A52	640352
EUROMAC							
S 14/35/ES 35/ES 24/530, PM 370/374/470/474/735, Titan 35, E35	35	3/8"	50	1,3	ø 4,0	A50	640350
FARM U. GARTEN							
P349, PR350	30 35	3/8" 3/8"	44 50	1,3 1,3	ø 4,0 ø 4,0	A44 A50	640344 640350
150EL	35	3/8"	52	1,3	ø 4,0	A52	640352
160EL, 165EL, 170EL, 180EL, 360P, 370P, 390P	35 40	3/8" 3/8"	50 56	1,3 1,3	ø 4,0 ø 4,0	A50 A56	640350 640356
FLEURELLE							
KSB 1735	35	3/8"	49	1,3	ø 4,0	A49	640349
KS1435, KS1640, KSE1640, KSE1845, KSE2040-1, KSB2035, KSB2640	35	3/8"	52	1,3	ø 4,0	A52	640352
KSB 2340	40	3/8"	55	1,3	ø 4,0	A55	640355
KS1435, KS1640, KSE1640, KSE1845, KSE2040-1, KSB2035, KSB2640	40	3/8"	57	1,3	ø 4,0	A57	640357
FOLUX							
F 30F	30	3/8"	44	1,3	ø 4,0	A44	640344
F 35, F 35F	35	3/8"	49	1,3	ø 4,0	A49	640349
FRONTIER							
MK 1=Quadra	30	3/8"	45	1,3	ø 4,0	A45	640345
GARDENA							
CST 3518, CST 3519-X	35	3/8"	52	1,3	ø 4,0	A52	640352
CST 4020-X	40	3/8"	57	1,3	ø 4,0	A57	640357
GRIZZLY							
BKS 35-12	30	3/8"	44	1,3	ø 4,0	A44	640344
Farmer MKS 350, BKS 35-14, BKS 38-14, BKS 38-16, EKS 1600, EKS 1800, EKS 400i, EKS 400TL, EKS 2000, P390, BKS 350, BKS 400, KSI 2000	35	3/8"	49	1,3	ø 4,0	A49	640349
BKS 35-32, BKS 35-38, PKS 360/390, EKS 2500QT	35	3/8"	50	1,3	ø 4,0	A50	640350
EKS 2000, EKS 2000QT, BKS 38-16, BKS 35-14, BKS 38-14, EKS 1600, EKS 1800, EKS 400i, EKS 400TL, P390, BKS 350, BKS 400, KS 400i, KSI 2000	40	3/8"	55	1,3	ø 4,0	A55	640355
BKS 35-14, BKS 35-38, BKS 35-40, BKS 38-14, BKS 38-16, PKS 360/390, EKS 1600, EKS 1700-40, EKS 1800, EKS 400i, EKS 400TL, EKS 2000, P390, BKS 350, BKS 400, KSI 2000	40	3/8"	56	1,3	ø 4,0	A56	640356
BKS 35-14, BKS 38-14, BKS 38-16, EKS 400i, EKS 400TL, EKS 1600, EKS 1800, EKS 1800-40, EKS 1850, EKS 2000, EKS 2000-6, EKS 2000-6QT, P390, BKS 350, BKS 400, KSI 2000	40	3/8"	57	1,3	ø 4,0	A57	640357
GRIZZLY-LIDL							
Parkside EKS 1700	40	3/8"	55	1,3	ø 4,0	A55	640355
GÜDE							
KS 400E	40	3/8"	57	1,3	ø 4,0	A57	640357
HANDY							
30HF, E 140F	30	3/8"	44	1,3	ø 4,0	A44	640344
35 HF	35	3/8"	49	1,3	ø 4,0	A49	640349

Saw chains classified by manufacturer





Manufacturer/machine model	Guide bar length cm	Spacing 	Drive links 	Drive link width 		kwb quick reference number	Part-No.
HANSEATIC							
1840 KS, 2040 KS	40	3/8"	57	1,3	ø 4,0	A57	640357
HERKULES							
18/41	40	3/8"	57	1,3	ø 4,0	A57	640357
41/41	40	3/8"	56	1,3	ø 4,0	A56	640356
HITACHI							
CS 280A, CS 280B	30	3/8"	45	1,3	ø 4,0	A45	640345
CS 350A, CS 350B	35	3/8"	52	1,3	ø 4,0	A52	640352
CS 35B	40	3/8"	57	1,3	ø 4,0	A57	640357
HOMELITE							
i335, i3350B, D 3850B, D 3850BC, 23AV, Sabre S 3350B, S 1035	30	3/8"	45	1,3	ø 4,0	A45	640345
i335, i3350B, D 3850B, D 3850BC, 23AV, Sabre S 3350B, S 1035, HCS 3435BA, CSP 3314, Bandit BSC 35, BanditXLX30, ECW 1636, HCS 3335, XL2 Super, XL, XEL, XLTI, 240SL	35	3/8"	52	1,3	ø 4,0	A52	640352
2014B, 20AV, HCS 3435BA, ECW 1641	40	3/8"	56	1,3	ø 4,0	A56	640356
CSP 4016	40	3/8"	57	1,3	ø 4,0	A57	640357
i3850B, D 4550B, D 3850BC, EZ-AO-130/150/290/340, XL-76/100/250, VI-123/125, VISuper Mini	38	.325	64	1,3	ø 4,8	D64	640864
HURRICANE							
MKS 38/35	35	3/8"	49	1,3	ø 4,0	A49	640349
HEK 18-35	35	3/8"	52	1,3	ø 4,0	A52	640352
ES 2040S	40	3/8"	55	1,3	ø 4,0	A55	640355
PS 200-40E	40	3/8"	57	1,3	ø 4,0	A57	640357
HUSQUARNA							
Husky 33, Husky 34	30	3/8"	45	1,3	ø 4,0	A45	640345
Husky 35, Husky 36, 315, 316, 318, 320 Electric	35	3/8"	52	1,3	ø 4,0	A52	640352
Husky 32, Husky 38	35	3/8"	53	1,3	ø 4,0	A53	640353
Husky 35, Husky 36, Husky 37, Husky 41, 315, 316, 318, 320 Electric	40	3/8"	56	1,3	ø 4,0	A56	640356
33, 36, 40, 41, 42, 44, 45, 49, 51, 55, 131, 136, 141, EL1200, E1400, E1600, EL16, 136, 137 e-serie, 140, 141, 142 e-serie, 340, 345, 346, 350, 351, 242XP	38	.325	64	1,3	ø 4,8	D64	640864
HUSQUARNA							
61, 75, 77, 162, 163, 181, 246, 262, 263, 266, 268, 272, 280, 281, 285, 286, 288, 289, 298, 365, 371, 380, 480 (XP/XPG), 61, 65, 66, 1100, 2100, 2100XP, 2101, 25XP, 245XPG, 254XP, 254XPG, 27, 262, 264, 288XPG, 338XPT, 334T, 365, 372XP, 385XP, 394XPG, 395XP, 395XPG, 3120XP, 55	38	3/8"	56	1,5	ø 4,8	L56	641756
IKRA							
MKS 30	30	3/8"	44	1,3	ø 4,0	A44	640344
KS30ST, KS400, KS12A, A104P PowerSharp, A104A	30	3/8"	45	1,3	ø 4,0	A45	640345
A104P+S, A204S, A205B, FA12, FA14, KS12, H014S, KS14, KS30ST, KS400, KS1200B, KS1250B, KS1300, Shark1300, KS1400, KS1400A, KS1400B, KS1500, KS1600, KS2000, 1200KS, Shark PE1400, Sup-Pro 1500, KS1500T, KS 1500TS, KS1700DL, KSE2000, EKS30, EKS35, EKS40, EKS1500-35, EKS1400, EKS1600, EKS1650, EKS1700, EKS1800, EKS2000, BKS301, BKS402, BKS4135, PKS40	30	3/8"	45	1,3	ø 4,0	A45	640345
	35	3/8"	52	1,3	ø 4,0	A52	640352
	40	3/8"	56	1,3	ø 4,0	A56	640356
	40	3/8"	57	1,3	ø 4,0	A57	640357
KS14A, H014A, A104P PowerSharp	35	3/8"	52	1,3	ø 4,0	A52	640352
KSI1600-35, KSI1600-40, KSI1800-40, KSE2000-35, KSE2000-40, KSE2000-45, KS1500TS	35	3/8"	52	1,3	ø 4,0	A52	640352
	40	3/8"	57	1,3	ø 4,0	A57	640357
	35	3/8"	52	1,3	ø 4,0	A52	640352
BKS4141	40	3/8"	56	1,3	ø 4,0	A56	640356
	35	3/8"	52	1,3	ø 4,0	A52	640352
KS1400T, KS1500T	40	3/8"	57	1,3	ø 4,0	A57	640357
KS1600T	40	3/8"	57	1,3	ø 4,0	A57	640357
CMI 1735BKS, BKS 35-14, KS 1938/35	35	3/8"	49	1,3	ø 4,0	A49	640349

Manufacturer/machine model	Guide bar length cm	Spacing 	Drive links 	Drive link width 		kwb quick reference number	Part-No.
IKRA							
MKS 35, KS1300Shark	35	3/8"	50	1,3	ø 4,0	A50	640350
EL1400, Hobby Cutter, KS1200B, KS1250, KS1400A, KS1400T, KS1400TF, KS1435, KS1600T-35, KS1600TF-35, KS1600TS-35, KS14A, A104P PowerSharp	35	3/8"	52	1,3	ø 4,0	A52	640352
BKS 38-16	40	3/8"	55	1,3	ø 4,0	A55	640355
KS1400B-40, KS1500B-40, KSB3940, MKS 40, Peifi Cutter, SEK 618	40	3/8"	56	1,3	ø 4,0	A56	640356
KS1640, BKS401, KSI2000-40, SWING1840KS, 2140KSE, Variolux, SWING2040KS, CMI2040S, Hanseatic 1840KSM, KSE2040, KS1600T-40, KS2000TF, KS2000TS, KS1600TF-40, 1640Shark, KF1800TF-40, KF1800TS-40, KS1400T/TS, KS1640, KS1800TF/TS, PKS40, KS2000TF/TS	40	3/8"	57	1,3	ø 4,0	A57	640357
JONSERED							
2033, 370, 380, CS2115EL, CS2120EL, CS2137	30	3/8"	45	1,3	ø 4,0	A45	640345
2036, 2040, 2033, 370, 380, CS2115EL, CS2120EL, CS2137	35	3/8"	52	1,3	ø 4,0	A52	640352
2036, 2040, 2033, 370, 380, CS2115EL, CS2120EL, CS2137	40	3/8"	56	1,3	ø 4,0	A56	640356
2016, 2036, 2040, 2041, 2045, 2050, 2054, 2055, CS2147, CS2152	38	.325	64	1,3	ø 4,8	D64	640864
CS2156, CS2159, CS2163, CS2165, CS2171	38	3/8"	56	1,5	ø 4,8	L56	641756
KINGCRAFT							
KS1500B	40	3/8"	56	1,3	ø 4,0	A56	640356
EKS1650, KSI2000-40	40	3/8"	57	1,3	ø 4,0	A57	640357
KOMATSU ZENOAH							
G31AVS, G310TS, G3100, G3200, G3300, G380AVS, G3800, G2800AVS	30	3/8"	45	1,3	ø 4,0	A45	640345
	35	3/8"	52	1,3	ø 4,0	A52	640352
	40	3/8"	57	1,3	ø 4,0	A57	640357
LIDL							
KSE1435, 1640, PKS 2000/4	40	3/8"	55	1,3	ø 4,0	A55	640355
MAKITA							
EL-UC 210R, DCS 34, UC 3010A, UC 3510U, DCS3400, DCS 3410, UC 4010A	35	3/8"	52	1,1	ø 4,0	C52	640652
SDK 100	30	3/8"	45	1,3	ø 4,0	A45	640345
Electric 5011B, Electric 5012B, Electric, 5014-NB, Electric 5016-B, Electric 5016-NB	30	3/8"	45	1,3	ø 4,0	A45	640345
	35	3/8"	52	1,3	ø 4,0	A52	640352
	40	3/8"	57	1,3	ø 4,0	A57	640357
DCS 33, DCS 34, DCS 300, DCS 330, DCS 330S, DCS 330TH, DCS 340, DCS 341, DCS 342, DCS 344, DCS 350, DCS 380, DCS 390, DCS 400, DCS 401, DCS 3300TH, DCS 3400TH, DCS 3401TH, DCS 3500, DCS 3501, DCS 4610, DES 350, DES 400, UC 300, UC 3000, UC 3000A, UC 3001A, UC 3003A, UC 3500, UC 3500A, UC 3501A, UC 3503A, UC 4000, UC 4000A, UC 4001A, UC 4003A, 5014B, 5016B, 5016NB	30	3/8"	46	1,3	ø 4,0	A46	640346
	35	3/8"	52	1,3	ø 4,0	A52	640352
	40	3/8"	56	1,3	ø 4,0	A56	640356
	40	3/8"	57	1,3	ø 4,0	A57	640357
ES 2000-400, EK 2000-400	40	3/8"	57	1,3	ø 4,0	A57	640357
DCS 410, DCS 411, DCS 4301, DCS 440, DCS 441, DCS 430, DCS 520, DCS 4300i, DCS 5200i	38	.325	64	1,3	ø 4,8	D64	640864
DCS 43, DCS 52, DCS 430, DCS 431, DCS 460, DCS 461, DCS 480, DCS 500, DCS 501, DCS 520, DCS 520i, DCS 4300, DCS 4600S, DCS 4600SH, DCS 5000, DCS 5001, DCS 5000H, DCS 5200i, DCS 6600, DCS 6000i, DCS 6400, DCS 6800, DCS 6800i, DCS 7300, DCS 7900	38	3/8"	56	1,5	ø 4,8	L56	641756
MAFELL							
EKS400S	38	.325	64	1,3	ø 4,8	D64	640864
MATRIX							
ES2000-400, EK2000-400	40	3/8"	57	1,3	ø 4,0	A57	640357
MAX BAHR							
Bahr 2000, Bonus 1800, EKS 1800-40, KSI 2000-40	40	3/8"	57	1,3	ø 4,0	A57	640357





Saw chains classified by manufacturer

Manufacturer/machine model	Guide bar length cm	Spacing 	Drive links 	Drive link width 		kwb quick reference number	Part-No.
MCCULLOCH							
Electramac 230/1030, 230, 312, 312s, 330, 1030, ES22, S12, Mac 930/12, Euromac 30/E30/ES30, Euromac S12, PM 360/364/730/930	30	3/8"	45	1,3	ø 4,0	A45	640345
E14, Electramac14E, ES80, 230, 1030, S22, ES30, Euromac35, 833, S12, S33, S34, Mac12, 130, 140, 833, 835, 836, Mini Mac30, Mini Mac833, PM730, Titan7	35	3/8"	49	1,3	ø 4,0	A49	640349
Electramac235, 1035, 35, Euromac530, S14, Mac Cut, Mac 538, 538a, 538e, 540, 545, 545e, 546, California, California 2000/Kit, 930,935, PM36, 370, 374, 470, 474, 486, 735, Titan35, PM 1-10, 2-10, 3-10, 4-10, 5-10, 6-10, 7-10, 10-10, 55, PM60, 70, 80, 81, 555, PM570, 610, 650, 655, PM700, 800, 805, 850, PM1000, DE-50, SP-60, Titan 50, 57	35	3/8"	50	1,3	ø 4,0	A50	640350
Mac 335, 435, MacCat 438	35	3/8"	52	1,3	ø 4,0	A52	640352
Electramac 240, 316, 316a, 340E, 1040, ES28, S16, Mac 538, 538e, 539e, 540, 540e, 545, 545e, 546, 838, 940, Mac Cat 839, California, California 2000/Kit, KSB2340, Mac6, Mac6B, Mac740, Mac940, PM486, EM30, Mac12, Mac28, MiniMac832, Titan7	40	3/8"	55	1,3	ø 4,0	A55	640355
MacCat 440, 441, 442	40	3/8"	56	1,3	ø 4,0	A56	640356
Electramac 16-EE, ES 30, 22, 24, 26, 35, 36, 40, PM-394, PM-494, M 1, 2, 2B, 4, 4B, 6, 6B, Californian, Arizona, Eager-Beaver, 10, 12, 12 A/S, 14 AVS, 16 E, 170, 374, 384, 394, 484, 494, 735, 930, 935, C 180, EM-8	30	3/8"	44	1,3	ø 4,0	A44	640344
	35	3/8"	49	1,3	ø 4,0	A49	640349
	35	3/8"	50	1,3	ø 4,0	A50	640350
	40	3/8"	55	1,3	ø 4,0	A55	640355
40	3/8"	56	1,3	ø 4,0	A56	640356	
PM 1-10, 2-10, 3-10, 4-10, 5-10, 6-10, 7-10, 10-10, 55, PM60, 70, 80, 81, 555, PM570, 610, 650, 655, PM700, 800, 805, 850, PM1000, DE-50, SP-60, Titan 50, 57	35	3/8"	50	1,3	ø 4,0	A50	640350
Mac110, 120, 130, 140, 160, PM300, PM310, PM320, PM330, PM340, PM360, PM364, PM370, PM380, PM394, PM470, PM474, PM480, PM484, PM494, PM530, PM538, PM540, 832, 833, 835, 836, 838, 839, 930, Euromac S32, S33, S34, S36, S40, S41, ELECTR	30	3/8"	44	1,3	ø 4,0	A44	640344
	35	3/8"	49	1,3	ø 4,0	A49	640349
	40	3/8"	55	1,3	ø 4,0	A55	640355
PM 3500, 4000, 400-P, 4500, 4700, 4900, 5000, Titan 35+40, Logger-Kit, 3500, 400P, T 35, T 40, PM 38, 40-46, T 46, T 48, ProMac 10-42, ProMac 10-49Pro, ProMac 40, ProMac 40II, ProMac 46, ProMac 46II, Timber	38	.325	64	1,3	ø 4,8	D64	640864
Mac 950, 951, 955, 960, 961, 970, Pro Mac 51, 55, 60, 61, 72, Titan 51, 61, Topso	38	3/8"	56	1,5	ø 4,8	L56	641756
METABO							
5338 B	30	3/8"	44	1,3	ø 4,0	A44	640344
KT 1441, KT1440	40	3/8"	57	1,3	ø 4,0	A57	640357
NAUTEC							
131	35	3/8"	52	1,3	ø 4,0	A52	640352
138	38	.325	64	1,3	ø 4,8	D64	640864
OBI-CMI							
CMI 1735BKS, 2115, EKS 1800-35	35	3/8"	52	1,3	ø 4,0	A52	640352
CMI 2040KS/KSI, 2040KSS, BKS45, KS 1840/1, KS 2000	40	3/8"	57	1,3	ø 4,0	A57	640357
OBI-DIANA							
1300-35KS	35	3/8"	52	1,3	ø 4,0	A52	640352
1400-40KS	40	3/8"	56	1,3	ø 4,0	A56	640356
O.K.							
EKS 1840	40	3/8"	57	1,3	ø 4,0	A57	640357
OLEO MAC OLYM.							
E 1500	35	3/8"	50	1,1	ø 4,8	C50	640650
937	35	3/8"	52	1,3	ø 4,0	A52	640352
35, 233, 234, 240, 241, 244, 335, 340, 930, 935D, 935X, 935DX, E140F, E160F, E170F, E1700, E170, E1900, E-200	30	3/8"	44	1,3	ø 4,0	A44	640344
	35	3/8"	49	1,3	ø 4,0	A49	640349
	35	3/8"	50	1,3	ø 4,0	A50	640350





... always the appropriate accessories for your machine!

Manufacturer/machine model	Guide bar length cm	Spacing 	Drive links 	Drive link width 		kwb quick reference number	Part-No.
OLEO MAC OLYM.							
936, 940C, E140	30	3/8"	44	1,3	∅ 4,0	A44	640344
	35	3/8"	49	1,3	∅ 4,0	A49	640349
	40	3/8"	56	1,3	∅ 4,0	A56	640356
931, 932, 932C	30	3/8"	45	1,3	∅ 4,0	A45	640345
	35	3/8"	52	1,3	∅ 4,0	A52	640352
935, 936, 940	35	3/8"	52	1,3	∅ 4,0	A52	640352
	40	3/8"	57	1,3	∅ 4,0	A57	640357
240, E170, E170F	40	.325	64	1,3	∅ 4,8	D64	640864
945, 950, 938, 941	38	.325	64	1,3	∅ 4,8	D64	640864
250, 250A, 251, 251B, 251S, 252, 254, 260, 261, 264, 271, 272, 280, 284, 350, 350S, 355, 460, 480, 481, 482, 484, E 300, OM-E 300, 956, 962, 970, 980	38	3/8"	56	1,5	∅ 4,8	L56	641756
OPEM							
130Z	30	3/8"	45	1,3	∅ 4,0	A45	640345
140Z, 142Z	35	3/8"	52	1,3	∅ 4,0	A52	640352
	40	3/8"	57	1,3	∅ 4,0	A57	640357
PARKSIDE							
KSE1435, KSE1640, EKS1650, 1700PKS40, 2000	40	3/8"	55	1,3	∅ 4,0	A55	640355
	40	3/8"	56	1,3	∅ 4,0	A56	640356
PARTNER							
1436, 1641	35	3/8"	52	1,1	∅ 4,0	C52	640652
1400E, 1500-EL, 1601, 1602, 1612, 1613, 1614, 1616, 1618	30	3/8"	44	1,3	∅ 4,0	A44	640344
	30	3/8"	45	1,3	∅ 4,0	A45	640345
	35	3/8"	50	1,3	∅ 4,0	A50	640350
	40	3/8"	56	1,3	∅ 4,0	A56	640356
330, 335, 340, 345, 350, 351, 357, 360, 365, 370, 371, 385, 389, 390, 405, P-420, P 740, P 842, P842CC	30	3/8"	45	1,3	∅ 4,0	A45	640345
	35	3/8"	50	1,3	∅ 4,0	A50	640350
	35	3/8"	52	1,3	∅ 4,0	A52	640352
	40	3/8"	56	1,3	∅ 4,0	A56	640356
1601,1602, 1612, 1613, 1614, 1616, 1618, 395, 420, 465	35	3/8"	52	1,3	∅ 4,0	A52	640352
341, 395, 420, 1200, 1450	30	3/8"	45	1,3	∅ 4,0	A45	640345
341, 395, 420, 1614	35	3/8"	50	1,3	∅ 4,0	A50	640350
P1535, P1550, 1640, P1850, P538, 538E	35	3/8"	50	1,3	∅ 4,0	A50	640350
	40	3/8"	55	1,3	∅ 4,0	A55	640355
P-21, 26, 28, 360, 365, 400, 405, 410, 411, 450, 460, P461, P461II, 462, P470, 500, P510, 511, 540, 543, 1074, 5000, EL 1450, EL 1650	38	.325	64	1,3	∅ 4,8	D64	640864
P 500, 605, P 5000	38	3/8"	56	1,5	∅ 4,8	L56	641756
550, 650, 660, 1633-B, F 55, F 65, P-55, 65, 70, 85, 7000, R-11, 12, 14, R-16, 17, 18, 19, 20, 21, R-22, 30, 40, 417, 418, R-420, 421,422, 435, R-440, 522, 523, S-50, 55, 65, 660, P-7700	38	3/8"	56	1,5	∅ 4,8	L56	641756
PEUGEOT							
TLS 1630, TRC 1630, TLS 1635, TLS 1635A, TRC 1635, TLS 1640, TRC 1640, EKS1740	30	3/8"	45	1,3	∅ 4,0	A45	640345
	35	3/8"	50	1,3	∅ 4,0	A50	640350
	40	3/8"	56	1,3	∅ 4,0	A56	640356
POULAN							
E 5300	35	3/8"	52	1,3	∅ 4,0	C52	640652
Micro 25, Micro 25A	30	3/8"	45	1,3	∅ 4,0	A45	640345
25A, S 25D, S 25DA, 1400E, 2000, 2300AV, 2300CVA, P 600, 2050, 2150, 2250, 2450, 2550, Woodshark, Pro4016	35	3/8"	52	1,3	∅ 4,0	A52	640352
2050, 2150, 2250, 2450, 2550, Woodshark, Pro4016	40	3/8"	56	1,3	∅ 4,0	A56	640356
25A, Micro 25, S 25 CVA, S 25D, S 25DA, 1800, 2000, 2300AV, 2300CVA, P 600	40	3/8"	57	1,3	∅ 4,0	A57	640357
2800, 2900, 3300, 3350	38	.325	64	1,3	∅ 4,8	D64	640864
PROVIL							
PVKS 20000E, PVKS 2000/1E	40	3/8"	57	1,3	∅ 4,0	A57	640357

Saw chains classified by manufacturer

Manufacturer/machine model	Guide bar length cm	Spacing 	Drive links 	Drive link width 		kwb quick reference number	Part-No.
REMINGTON							
860 AV, Cutter, EL6 DELUXE	30	3/8"	45	1,3	ø 4,0	A45	640345
Mighty Mite 500/812/814	35	3/8"	49	1,3	ø 4,0	A49	640349
Electricpower, Limb`n`-Trim, 1450	35	3/8"	50	1,3	ø 4,0	A50	640350
RYOBI							
35B, CS 36C, CS 41, CSE 330, CSE 3330, CSE 385CB, HC 31, HCS 31, HC 36, HC 41, CS 1530, CS 1535, CS 1540	30	3/8"	44	1,3	ø 4,0	A44	640344
	35	3/8"	49	1,3	ø 4,0	A49	640349
	40	3/8"	55	1,3	ø 4,0	A55	640355
CS 290, C 300, CS1530	30	3/8"	44	1,3	ø 4,0	A44	640344
CSE 385CB, HC 36, CS 360, CS1535	35	3/8"	49	1,3	ø 4,0	A49	640349
CSP 3314, ECW 1636, PCN 3335, RCS 3335	35	3/8"	52	1,3	ø 4,0	A52	640352
CS 41, HC 41, CS1540	40	3/8"	55	1,3	ø 4,0	A55	640355
HCS 3435BA	40	3/8"	57	1,3	ø 4,0	A57	640357
CSN 410, ECW 1641, HCS 340BA	40	3/8"	56	1,3	ø 4,0	A56	640356
SABRE							
S 3350B, 1035, CS 35, BCS 35	35	3/8"	52	1,3	ø 4,0	A52	640352
SHARK							
1300-35	35	3/8"	50	1,3	ø 4,0	A50	640350
BKS3540	35	3/8"	49	1,3	ø 4,0	A49	640349
SHINDAIWA-SDK-ISEKI							
SBA-P230	30	3/8"	50	1,1	ø 4,0	C44	640644
140, 160, 285s, 300s, 305s, 305AVZ, 340, 345, 346, 350, 352s, 355, 357, 357s, 360, 377, 391, 395, A-090, 102, 103, 104, 105, 107, 110, 110P, 113L+P, 117P, 100, E 150, 315, YB 301, YB 401, A 090B, A 100C, A 102, A 150B	30	3/8"	45	1,3	ø 4,0	A45	640345
	35	3/8"	52	1,3	ø 4,0	A52	640352
	40	3/8"	57	1,3	ø 4,0	A57	640357
1600 ES	40	3/8"	57	1,3	ø 4,0	A57	640357
360, 366, 370, 394, 400, 415, 416, 420, 450, 451, 457, 488, 495, 500, 506, 510, 560, 601, 691, A-180B, YB 501, YB 601, YB 701	38	.325	64	1,3	ø 4,8	D64	640864
SHINGU							
SP 3200, SP 3200T, SP 3400	35	3/8"	52	1,3	ø 4,0	A52	640352
SP 3400	40	3/8"	57	1,3	ø 4,0	A57	640357
SKIL							
1600HE, 1601HE, 1602HE, 1603H, 1604H, 1606H, 1610U, 1612U, 1616U, 1620U, 1634U, 1636U, 1712U	30	3/8"	45	1,3	ø 4,0	A45	640345
	35	3/8"	52	1,3	ø 4,0	A52	640352
	40	3/8"	57	1,3	ø 4,0	A57	640357
SOLO							
633, 636-Microlite	35	3/8"	52	1,1	ø 4,0	C52	640652
613, 614, 620, 630, 633, 635, 635ECO, 636, 637, 640, 643	30	3/8"	45	1,3	ø 4,0	A45	640345
	35	3/8"	52	1,3	ø 4,0	A52	640352
	40	3/8"	57	1,3	ø 4,0	A57	640357
634, E-105, KSB 2035	35	3/8"	50	1,3	ø 4,0	A50	640350
662, KSB 2640	40	3/8"	56	1,3	ø 4,0	A56	640356
662, 670, 680, 690	38	3/8"	56	1,5	ø 4,8	L56	641756
634, 639, 645	38	.325	64	1,3	ø 4,8	D64	640864
STARK-SYMPRA-SYMPRATEC							
1400, 1412, 1430, 14830	30	3/8"	44	1,3	ø 4,0	A44	640344
1414, 1435, 14350, 14835	35	3/8"	49	1,3	ø 4,0	A49	640349
1416, 1500, 1600, 1616, 1440, 14840, 16840	40	3/8"	55	1,3	ø 4,0	A55	640355
STAYER							
SEC 40	40	3/8"	56	1,3	ø 4,0	A56	640356
STEINMAX							
CS 300	30	3/8"	44	1,3	ø 4,0	A44	640344
CS 360	35	3/8"	49	1,3	ø 4,0	A49	640349

... always the appropriate accessories for your machine!

Manufacturer/machine model	Guide bar length cm	Spacing 	Drive links 	Drive link width 		kwb quick reference number	Part-No.
STIGA							
SP 340	30	3/8"	44	1,3	ø 4,0	A44	640344
930	30	3/8"	45	1,3	ø 4,0	A45	640345
935, SP 340, SE 1.6	35	3/8"	50	1,3	ø 4,0	A50	640350
SE 1.8, SE180, SE 190, SE 200Q, SP 370, SP 410, SPR 350	35	3/8"	50	1,3	ø 4,0	A50	640350
	40	3/8"	56	1,3	ø 4,0	A56	640356
SP 410, SP 370	38	.325	64	1,3	ø 4,8	D64	640864
STIHL							
009, 017, 018, 019/T, 23L, E 140, MS 170, MS 171C, MS 180, MS 181, MS 190T, MS 192, MS 192T, E14, MSE 140, HT 70/75	30	3/8"	44	1,1	ø 4,0	C44	640644
	35	3/8"	50	1,1	ø 4,8	C50	640650
009, 010, 011, 012, 015, 018C, 019, 020, 020/T, 021, 023, 023C, 023L, 025, 025C, E 10, E 14, E 20, E 140, E 160, E 180, E 180C, E 220, E 220C, MS 180C, MS 190, MS 190T, MS 200, MS 200T, MS 210, MS 211, MS 230, MS 250, MSE 160, MSE 180, MSE 200, AVH-Elektronik	30	3/8"	44	1,3	ø 4,0	A44	640344
	35	3/8"	50	1,3	ø 4,0	A50	640350
	40	3/8"	55	1,3	ø 4,0	A55	640355
024/WB, 025, 026/C/W/CW/WB/WVH, 028, 028/S/WB/AV/EQ, MS 240, MS 260, MS 270, MS 280	38	.325	62	1,6	ø 4,8	G62	641262
029, 030, 031, 032, 034/S, 036/W/WVH, 036QS, 038, 039, 041, 042, 044, 045, 046, 048, 056, 064, E-10, E-16, E-20, E-220, MS 290 MS 310, MS 360/C, MS 390, MS 440/C, MS 460/C, MS 660	40	3/8"	60	1,6	ø 4,8	M60	641860
SWING							
1840KS, 2040KS	40	3/8"	57	1,3	ø 4,0	A57	640357
TALON							
	30	3/8"	45	1,3	ø 4,0	A45	640345
	35	3/8"	49	1,3	ø 4,0	A49	640349
AC2101, AC2105, AC2109, AC2111, AC3100	35	3/8"	52	1,3	ø 4,0	A52	640352
	40	3/8"	55	1,3	ø 4,0	A55	640355
	40	3/8"	56	1,3	ø 4,0	A56	640356
TAS-TANAKA							
TPS 2501, TPS 2501S, TPS 2510, RPS 200H	30	3/8"	44	1,1	ø 4,0	C44	640644
	30	3/8"	45	1,3	ø 4,0	A45	640345
290, 300, ECS 320, ECS 330, ECS 3301, ECS 3351, ECS 3401, TCS 3301S, TCS 3401	35	3/8"	52	1,3	ø 4,0	A52	640352
	40	3/8"	57	1,3	ø 4,0	A57	640357
TECHNIC TOOL							
PP 1250	30	3/8"	44	1,3	ø 4,0	A44	640344
TOPCRAFT							
KSI2000-40, EKS1700, EKS1750, EKS1800	40	3/8"	56	1,3	ø 4,0	A56	640356
	40	3/8"	57	1,3	ø 4,0	A57	640357
TURBO SILENT							
BKS3536	35	3/8"	52	1,3	ø 4,0	A52	640352
BKS4041	40	3/8"	56	1,3	ø 4,0	A56	640356
EKS2040	40	3/8"	57	1,3	ø 4,0	A57	640357
UNIROPA							
BKS3840	35	3/8"	49	1,3	ø 4,0	A49	640349
	35	3/8"	52	1,3	ø 4,0	A52	640352
KSE2035, KSI1800-35, KSE2040, KSI20-40	40	3/8"	57	1,3	ø 4,0	A57	640357
VARIOLUX							
2135KSE, 2140KSE, 2335BKS, 2340BKS	35	3/8"	52	1,3	ø 4,0	A52	640352
	40	3/8"	57	1,3	ø 4,0	A57	640357
ZENOAH							
G 300T, G 300AVS	30	3/8"	46	1,3	ø 4,0	A46	640346
G 310TS, G 320AV, G 320AVS, G 3100, G 3200	35	3/8"	52	1,3	ø 4,0	A52	640352
G 380AV, G 380AVS, G 3800AVS	40	3/8"	57	1,3	ø 4,0	A57	640357
G 415AVS-16	38	.325	64	1,3	ø 4,8	D64	640864



NYLON TRIMMER LINE

... always the appropriate accessories for your machine!



Nylon trimmer line



Nylon line for trimmers (grasscutters)

The nylon line is particularly suitable for light grass and thin undergrowth in popular trimmers in lawnmowing mode.

Profi nylon line for trimmers (brushcutters)

The extra strong nylon line for professional use is particularly suitable for tough grass and undergrowth in popular trimmers and brushcutters

Programme overview nylon trimmer line

Nylon trimmer line



Nylon trimmer line, white for grass and light undergrowth, for market leading trimmers and brushcutters

Art.-No.	Ø mm	Length			EAN
654113	Thread Ø mm 1,3	15 m		1	4 009316 541135
654116	Thread Ø mm 1,6	15 m		1	4 009316 541166
654120	Thread Ø mm 2,0	15 m			4 009316 541203
654124	Thread Ø mm 2,4	15 mm			4 009316 541241



Nylon trimmer line PROFI



Nylon trimmer line PROFI, yellow, extra thick, for tough grass and undergrowth, for professional use, for commonly used trimmers and brushcutters.

Art.-No.	Ø mm	Length			Barcode
654213	Thread Ø mm 1,3	15 m		1	4 009316 542132
654216	Thread Ø mm 1,6	15 m		1	4 009316 542163
654220	Thread Ø mm 2,0	15 m		1	4 009316 542200
654224	Thread Ø mm 2,4	15 m		1	4 009316 542248



... always the appropriate accessories for your machine!





TACKERS
STAPLES
HOT MELT
GLUE GUNS

Tackers, staples, brads



Tackers

- Profi electronic tackers, TT series
- Profi industrial hand tackers, MT series
- Profi hand tackers, PT series
- Profi hammer tackers, HAT series

Fastenings for hand and electronic tackers

Find the correct fasteners in our compatibility chart on pages 319 - 325.

Programme overview



Profi electronic tackers TT

★★★★★

For use with staples, pins and brads, extra high impact force, with safety lever to prevent accidental discharge, ideal for work in roofing and panelling.

Page 314



Profi hammer tacker HT

★★★★★

The hammer tacker is used like a hammer, with rapid blows driving the staples into the workpiece, ideal for quick stapling in roofing work.

Page 314



Industrial hand tacker MT

★★★★★

With metal body, for use with staples, pins and brads, ideal for use in workshop, household and garden.

Page 315



Profi hand tacker PT

★★★★★

With glass fibre reinforced plastic body, for use with staples, pins and brads, ideal for use in workshop, household and garden

Page 315

Fastenings for hand and electronic tackers

Application guide for staples

Fine wire

The universal staple for many uses, with paper, cardboard, textiles, upholstery, wire netting, hobbies, handicrafts, thin wooden mouldings.

Fine wire, rust-free Monel material

For all outdoor uses, will not rust. For use with paper, card, textiles, wire netting, waxed and oiled paper, labels, upholstery in boatbuilding.

Brads

A nail for many uses for craftworker and DIY. Suitable for easy fixing of the material, such as trims, edging, case making, mouldings and panels.

Flat wire

Fastening for special, thin materials. For use with paper, cardboard, textiles, upholstery, wire netting, hobbies, handicrafts, roofing felt, foils, roofing, edging strips, aluminium cladding, cork tiles, waxed and oiled paper, labels. Staples with D-point especially for wooden mouldings, wall and ceiling panels.

Narrow shoulder staples

Deep penetrative staples with extra pull-out resistance. For use with mouldings, panels, fibreboard, wire netting, plywood.

Hot melt glue guns



Hot melt glue guns ★★★★★

The mechanical feed delivers the glue to the heater at the correct rate to deliver melted glue at the nozzle, apply dots or small lines of hot liquid glue to the work-piece, then as the glue cools it hardens and bonds the pieces together.

Page 326

Hot melt glue guns

- for quick and durable bonding in handicrafts, repairs and decorating
- multi material glue for household, workshop and hobby
- pinpoint accurate glueing of metals, glass, ceramics, marble, wood, leather, textiles and plastics
- weatherproof adhesive



Glue sticks ★★★★★

Glue sticks in 7 mm and 11 mm diameters, and 100 mm and 200mm lengths.





For bonding a variety of materials. Fits standard hot melt glue guns. Ideal for use in handicrafts, or small repair jobs in household and workshop.

Page 327

Electronic tacker TACKERTRONIX® TT 26







Electronic tacker TACKERTRONIX® TT 26, professional tool in aluminium case, extra high power, safety lever prevents accidental discharge, 220V/50/60 Hz supply, double insulated, radio/TV suppressed, 20 strokes/min, for type 53 staples up to 26mm, and type 55 brads up to 25mm.

Art.-No.	for staples	for pins/brads			Barcode
532600	Type 055 / 12-26mm	Type 055 / 16-25mm		1	 4 009315 326009

Electronic tacker TACKERTRONIX® TT 18



Electronic tacker TACKERTRONIX® TT 18, professional tool in aluminium case, extra high power, safety lever prevents accidental discharge, 220V/50/60 Hz supply, double insulated, radio/TV suppressed, 20 strokes/min, for type 53 staples up to 20mm, and type 55 brads up to 19mm.

Art.-No.	for staples	for pins/brads			Barcode
531800	Type 055 / 12-26 mm	Type 055 / 16 + 19mm		1	 4 009315 318004

Electronic tacker TACKERTRONIX® TT 14



Electronic tacker TACKERTRONIX® TT 14, extra high power, safety lever prevents accidental discharge, 220V/50/60 Hz supply, double insulated, radio/TV suppressed, 20 strokes/min, for type 53 staples up to 14mm, and type 55 brads up to 16mm

Art.-No.	for staples	for pins/brads			Barcode
531400	Type 053 / 6-14 mm	Type 055 / 16mm		1	 4 009315 314006

PROFI hammer tacker HT 057



PROFI hammer tacker HT 057, hand grip with finger guard, magazine takes up to 160 staples, with spare striker, for type 57 staples up to 10mm

Art.-No.	for staples			Barcode
057057	Type 057 / 6-10mm		1	 4 009310 570575

Hammer tacker HT 053



Hammer tacker HT 053, handgrip with finger guard, magazine takes up to 200 staples, for type 53 staples up to 8mm

Art.-No.	for staples			Barcode
053053	Type 053 / 4-8mm		1	 4 009310 530531

Tackers

PROFI TACK MT 16 N, Industrial hand tacker



PROFI TACK MT 16 N, Industrial hand tacker, heavy duty metal construction, continuously adjustable impact force, for long-term professional use, soft grip, takes type 53 staples up to 16mm, type 55 brads and pins up to 16mm.



Art.-No.	for staples	for pins/brads			Barcode
053416	Type 053 / 4-16mm	Type 055 / 16mm		1	4 009310 534164



PROFI TACK MT 10, Industrial hand tacker



PROFI TACK MT 10, Industrial hand tacker, heavy duty metal construction, continuously adjustable impact force, for long-term professional use, takes type 53 staples up to 16mm, and type 59 staples up to 16mm

Art.-No.	for staples			Barcode
053410	Type 053 / 6-10 mm and Type 059 / 6-10mm		1	4 009310 534102



BLUE TACK PT14 N, Profi hand tacker



BLUE TACK PT 14N, Profi hand tacker, plastic constructions, glass-fibre reinforced with impact force adjustment, soft grip with slip guard, for type 53 staples up to 14mm, type 55 pins and brads up to 16mm



Art.-No.	for staples	for pins/brads			Barcode
053314	Type 053 / 6-14 mm	Type 055 / 16mm		1	4 009310 533143



BLUE TACK PT 10, Profi hand tacker



BLUE TACK PT 10, Profi hand tacker, plastic construction, glass-fibre reinforced with impact force adjustment, soft grip with slip guard, for type 53 staples up to 10mm



Art.-No.	for staples			Barcode
053310	Type 053 / 4-10mm		1	4 009310 533105



BLUE TACK PT 8, Profi hand tacker



BLUE TACK PT 10, Profi hand tacker, plastic construction, glass-fibre reinforced with impact force adjustment, soft grip with slip guard, for type 53 staples up to 8mm

Art.-No.	for staples			Barcode
053308	Type 053 / 4-8mm		1	4 009310 533082















Staples, 12.3mm wide, flat wire, standard



Quality steel wire, high pull-out resistance, suitable for handicrafts, hobbies, paper, card, upholstery.











Art.-No.	Contents	Staple height			Barcode
Type 052/352, flat wire, steel, C-point					
352106	1400	6		5	
352108	1000	8		5	
352110	900	10		5	
352112	750	12		5	
352114	600	14 (D-point)		5	

Staples, 11.4mm wide, fine wire, standard











Quality steel wire, high pull-out resistance, suitable for handicrafts, hobbies, paper, card, upholstery, textiles, wire mesh.



Art.-No.	Contents	Staple height			Barcode
Type 053/353, fine wire, STANDARD, C-point					
353004	2000	4		5	
353006	1800	6		5	
353008	1400	8		5	



















Art.-No.	Contents	Staple height			Barcode
Type 053/353, fine wire, STANDARD, C-point					
053040	5000	4		1	
053060	5000	6		1	
053080	5000	8		1	

Staples, 11.4mm wide, fine wire, steel



Quality steel wire, high pull-out resistance, suitable for handicrafts, hobbies, paper, card, upholstery, textiles, wire mesh, thin wooden battens.

















Art.-No.	Contents	Staple height			Barcode
Type 053/353, fine wire, steel, C-point					
353106	1800	6		5	
353108	1400	8		5	
353110	1200	10		5	
353112	1200	12		5	
353114	1000	14		5	
353116	800	16		5	
353120	600	20		5	

Staples and brads

Staples, 11.4mm wide, fine wire, steel









Art.-No.	Contents	Staple height			Barcode
Type 053/353, fine wire, steel, C-point					
053061	5000	6		1	
053081	5000	8		1	
053101	5000	10		1	
053121	5000	12		1	
053141	5000	14		1	
053181	5000	18		1	



Staples, 11.4mm wide, fine wire, non-rusting Monel metal















Art.-No.	Contents	Staple height			Barcode
Type 053, fine wire, stainless steel					
353585	1400	8		5	
353605	1200	10		5	

Quality steel wire, high pull-out resistance, suitable for boatbuilding, upholstery in boatbuilding, textiles, wire mesh, thin wooden battens.



Staples, 6.1mm wide, narrow shoulder, steel















Art.-No.	Contents	Staple height			Barcode
Type 055/355, narrow shoulder, steel, C-point					
355112	1200	12		5	
355115	1000	15		5	
355118	800	18		5	
355123	600	23		5	
355128	600	28		5	

Quality steel wire, high pull-out resistance, suitable for mouldings, panels, fibreboard, plywood, wire netting.



Staples, 10.7mm wide, flat wire, steel









Art.-No.	Contents	Staple height			Barcode
Type 057/357, flat wire, steel, C-point					
357106	1400	6		5	
357108	1000	8		5	
357110	900	10		5	
357112	750	12		5	
357114	600	14 (D-point)		5	

Quality steel wire, high pull-out resistance, suitable for paper, card, labels, roofing felt, films, waxed and oiled paper.



Staples, 10.7mm wide, flat wire, steel









Art.-No.	Contents	Staple height			Barcode
Type 057/357, flat wire, steel, C-point					
057081	5000	8		1	 4 009310 570810
057101	5000	10		1	 4 009310 571015

Staples, 13.0mm wide, fine wire, steel



Quality steel wire, high pull-out resistance, suitable for handicrafts, hobbies, paper, card, upholstery, woodwork.













Art.-No.	Contents	Staple height			Barcode
Type 058/358, fine wire, steel, C-point					
358108	1400	8		5	 4 009313 581080
358110	1200	10		5	 4 009313 581103

Staples, 10.6mm wide, fine wire, steel



Quality steel wire, high pull-out resistance, suitable for handicrafts, hobbies, paper, card, upholstery, woodwork.















Art.-No.	Contents	Staple height			Barcode
Type 059/359, fine wire, steel, C-point					
359106	1800	6		5	 4 009313 591065
359108	1400	8		5	 4 009313 591089
359110	1200	10		5	 4 009313 591102
359114	1000	14		5	 4 009313 591140

Brads, head approx. Ø 2,0 mm, extra strong wire, steel





Quality steel wire, suitable for trims, battens, case making, mouldings, panels, skirtings.



Art.-No.	Contents	Staple height			Barcode
Type 055/355, extra strong wire, steel, C-point					
355716	750	16		5	 4 009313 557160
355719	750	19		5	 4 009313 557191
355725	500	25		5	 4 009313 557252
355728	500	28		5	 4 009313 557283
355730	500	30		5	 4 009313 557306

Fastenings for hand and electronic tackers

		Staples						Brads
kwb-Type	052	053	055	057	058	059	055	
Part-No.	352-	353- 053-	355-1 055-5	357-	358- 058-	359-	355-7 055-7	
 ↓ mm	6-14	4-20	12-30	6-18	8	6-14	12-30	
Manufacturer / machine model								
AEG								
Powertac 14								
Powertac 16							16	
Powertac 18								
Powertac 19			12-18				19	
Powertac 30			18-30				16-30	
ARROW								
JT 21 M, JT 21 CM, T 27		6-10						
T 30					6-10			
T 32, T 32 M					4-8			
T 50, T50 OC, T 55, T 55C				6-16				
CT 50, ETC 50, ETN 50				6-16				
T 50 PBN,, ETL 50				6-16			16	
ETF 50 PBN, 50 BN, X50				6-16			16	
ET 200							15-32	
HT 30						6-10		
HT 50, HTX 50, HAT 55				8-12				
Powershot 5700, 8000				6-16			16	
Powershot 5650		6-16		6-16			16	
BLACK & DECKER								
A 5980		6-10						
A 5751		4-8						
A 5752		8-14						
A 5918, A 1818	6-14							
BD 418, DN 418, KX 418 E	6-14							
BD 428, DN 428, KX 428 E			16-30					
Powershot				6-14			16	
Powerfix			16-30					
SR 190 E, SR 190 EK			16-30					
BOSCH								
HT 8, HMT 53		4-8						
HT 14		4-14						
HMT 57				6-10				
PTK 3,6 LI		4-10						
PTK 14 E, EDT, PTK 3,6 V		6-14						
PTK 19 E		8-18	12-19				16-19	
PTK 23 E		12-19	12-23				23	
PTK 28 E		12-18	12-28				23-28	
BOSTITCH								
see STANLEY								
BUKAMA								
Plattennagler Ro 430			30					
BULLKRAFT								
972/207		8-18						
978/132, 979/910, 980/528		4-14						
CASALS								
GR 14								
EMHARD								
POP 1000		6-8						
POP 2000, POP 3000				6-14				
POP 4000				8-18				
ESCO								
Derby 530, S 530, Decora 530		4-8						
Esco 10, 20, HHT 53056,		4-8						
HT 53051, 53052		4-8						
ET 53031, 53055, AT 53001		6-14					16	

		Staples						Brads
kwb-Type		052	053	055	057	058	059	055
Part-No.		352-	353- 053-	355-1 055-5	357-	358- 058-	359-	355-7 055-7
 ↓ mm		6-14	4-20	12-30	6-18	8	6-14	12-30
Manufacturer / machine model								
ESCO								
HT 53053, 53055			6-14					
Compacta 530, C 530, N 530			4-14					
Esco 30, 40			6-14					
Type 58, 58 N						6-14		
Esco 50, 90			6-14					16
200 Electronic				12-25				16-25
100 Electronic			6-14					16
Rally S 530			6-14					
HHT 11					6-10			
HHT 19							4-6	
DLT 530, DLT 53071			8-18					
DLT 606, DLT 60672				15-30				
Multitro. 530, Variotro. P 530			8-18					
Variotronic 530 Akku			8-18					18
Duotronic, Profitronic				18-30				
Rally 500, Compacta N 500					6-14			
Robusta 606				15-23				
Multitronic 500					8-18			
EINHELL								
BT-EN 30 E				15-25				15-32
FIXIT								
M 100, S 100			x					
M 100 B			x					x
200			x					x
400			x					x
IRONSIDE								
1000			x					
1500					x			
2500					x			
2000			x					x
2200			x					x
2600					x			x
KWB								
T 6			6-8			6-8		
T 8, T 9, PT 6, PT 8			4-8					
PT 10			4-10					
T 14			4-14					
PT 14 N, TT 14			6-14					16
T 15								12-14
T 17			4-17					12-16
PT 18 N			8-18					19
MT 10			6-10					
MT 16 N			8-16					16
MT 20 N			8-20					16-19
TN 30								16,19
TT 13			6-14					
TT 18			8-20					16,19
TT 19			8-18					19
TT 19 S			8-18	14-18				19
TT 26				12-26				16-25
TT 28			14-18	12-28				19-28
TT 30				18-30				16-30
TT 42				15-32				
HAT 053			4-8					
HAT 057					6-10			

Fastenings for hand and electronic tackers

		Staples						Brads
kwb-Type		052	053	055	057	058	059	055
Part-No.		352-	353- 053-	355-1 055-5	357-	358- 058-	359-	355-7 055-7
 ↓ mm		6-14	4-20	12-30	6-18	8	6-14	12-30
Manufacturer / machine model								
KWB								
AT 14			6-14					
AT 32				12-33				
KIHLBERG								
7 T 70					x			
7 T 72					x			x
LUX								
Decotacker			6-8			6-8	6-8	16
Multitacker, Profitacker						6-14		16
Tackermatic-Elektronik				12-18		8-18		19/20
Tackermatic P								16
Mini			4-8					
Maxi								
195000, 195010, 195020,			6-8/14					
195030, 195050			6-8/14					
195015, 195040, 195060			6-8/14					16
195055					6-14			
HHT mini 196250			6-8					
HHT mini 196251					6-10			
MAESTRI								
Rocama 104/107, 104/107CA			6-8					
Rocama 104/707SA			6-8					
105/108/110			6-10					
TH 53/8 - TAK 53/8			4-8					
THB 53/8			4-8					
THB 53/10 - TAK 53/10B			4-10					
THB 53/14 - TAK 53/14B			6-14					16
5314/5310			6-14					
5316			6-16					16
53 Elektronik			8-20					19
EHB T 50, T 50 Elektronik					6-14			
ME 4/606 Elektronik				12-26				16-25
Technika 1310							4-10	
ME 30, MET 30								16-30
MAXICRAFT								
10200, 10201, 10202, 10203			x					
10211, 10301, 10302, 10303			x					
10401			x					
10204, 10220E			x					x
10416, 10417, 10510			x					x
10408			x			x		
10420							x	
METABO								
TA E 1819			8-18					19
TA E 1919, 2019 (.00)			8-18	12-18				19
TA E 2019 (.50)			8-18	12-18				19
TA E 3030				18-30				16-30
TA M 2020			8-18	12-18				19
TA M 3034				18-30				16-30
TA A 19			8-18	12-18				19
MEKANO-FISCHER-DAREX								
Mini 4			4-6					
Maxi 10, MEK 10			4-10					
Hyper 16, MEK 16, MEK 20					6-14			
H 100			6-14					
MEK 116			6-14					15

... always the appropriate accessories for your machine!

		Staples						Brads
kwb-Type		052	053	055	057	058	059	055
Part-No.		352-	353- 053-	355-1 055-5	357-	358- 058-	359-	355-7 055-7
 ↓ mm		6-14	4-20	12-30	6-18	8	6-14	12-30
Manufacturer / machine model								
MEKANO-FISCHER-DAREX								
MEK 1020			8-14					15-19
C 300								
MÜLLNER								
T 8, HT 08			4-8					
HT 01			6-8					
TP 53-10, TM 53-10			4-10				4-10	10
HT 5310, HT 5310M			4-10				4-10	10
T 14			4-14					
TP 53-14, HT 16, TE 53-14			6-14					16
TM 53-16			6-16				4-16	16
HT 5316K, HT 5316M			6-16				4-16	16
HT 18			6-18					
TP 53-16			8-18					16
TM 53-20, TE 53-20			8-20					16
TE 4-25				12-26				19-26
TH 11-10, HT 031					6-10			
ET 5314			4-14					15
DT 5316			4-16					
DT 440				15-40				
NOVUS								
J-01, J-01 A, J-01 AS			6-8					
J-02			4-6					
J-02 H							4-8	
J-02 AL			6-14					
J-03						6-8		
J-06			4-8			4-8		
J-08, J-08 ABH, J-09 ABH			4-8			4-8	4-8	
J-08 XX			4-8		4-6	4-8	4-8	
J-09 XX			4-8		4-6	4-8	4-8	
J-14			4-17			4-17		16
J-15						6-14		16
J-16, J-16 EAD, J-19 EAD			6-14					16
J-16 EADHG			6-14		6-14		6-14	16
J-17, J-100			6-14					16
J-17 DA			6-14					
J-18			6-18					16
J-19 EHG					6-14		6-14	16
J-19 EADHG			6-14		6-14		6-14	16
J-021 H							4-6	
J-031 G, J-030 G					6-10			
J-58 Trig						6-15		
J-102 DA			6-14					
J-105 EADHG			6-14		6-14		6-14	16
J-141, J-145			8-18	12-18				19
J-155 A, J-155, J-219			8-18	12-18				19
J-165 EAD			8-20					16-19
J-165 EC				15-26				16-25
J-170				18-26				16-30
J-170 N								16-30
J-171, J-172 A, J-230				18-30				16-30
J-214 EA			6-14					14
J-316 A			6-16	15-28				16-30
J-328 EC								
NECKERMANN								
see BULLCRAFT								

Fastenings for hand and electronic tackers

		Staples						Brads
kwb-Type		052	053	055	057	058	059	055
Part-No.		352-	353- 053-	355-1 055-5	357-	358- 058-	359-	355-7 055-7
 ↓ mm		6-14	4-20	12-30	6-18	8	6-14	12-30
Manufacturer / machine model								
PEUGEOT								
Pactronic 14 A, AG 14 A								
Rafale								
PIRANHA								
X 70101, 70102								
X 70004								
X 70005, 70006								
PROXON								
AT 1000								
RAPESCO								
53 EL								
913								
853-D/T/P								
13 EL								
813-D/T/P								
140 EL								
A 11								
HD 140								
180 EL, 181 EL								
Z 140								
Z1-P/Z1								
Z2-P/Z2								
RAPID								
MS813, R83, ESN113								
MS840, R64, CSN140,								
ESN114, E-Tac								
MS853, R453, E100R, ESN530								
R553								
MS4.1								
R34, R44								
M10R, R153								
M10Y, R23								
M20R, M30								
M20Y								
M40								
MS610								
R13								
R14, 24								
R253, R353								
R30								
R33, 136, BLT								
R53								
EN330, PN15-30								
PN15-50								
R606								
PSN15-30								
18G								
PS6-16								
R11, 131, 132								
R19								
R211								
R54								
35, 135								
REXEL								
2001								
Lo-Line								

... always the appropriate accessories for your machine!

		Staples						Brads
kwb-Type		052	053	055	057	058	059	055
Part-No.		352-	353- 053-	355-1 055-5	357-	358- 058-	359-	355-7 055-7
 ↓ mm		6-14	4-20	12-30	6-18	8	6-14	12-30
Manufacturer / machine model								
REXEL								
Rexel 37, Titan 12H, Titan Twin							x	
Titan 12H							x	
Titan Twin							x	
ROCAGRAF								
ROC 14, 11			4-8			4-8	4-8	
ROC 36						6-15		15
ROC 220						6-15		15
ROC 66			6-18			6-17		15
ROC 310								15
Modell 11/Colibri			4-6					
Modell 55, Junior 3, Fix 3						6-14		
Junior 4, ME 30								15-30
Fix 102, 103			4-8					
Fix 106			4-14					
MS 50 V					6-14			
Modell 14						6+8		
ROCAFIX								
EN 330								15-30
ES 230			6-14					15
ES 130					6-14			15
HS 21			6-8					
HS 50					6-10			
MS 05			4-8					
MS 10			6-12			6-15		
MS 100-110			4-8				4-8	
MS 15					6-12			
MS 20			6-12					
MS 30, 40			6-12					15
MS 35					6-12			15
MS 50 V					6-14			
MS 500					6-14			
MS 500B			6-14					
RONDY								
50					x			
60			x					
SKANDIA								
Modell 34.85.101			4-8					
Modell 34.85.103			4-14					
SKIL								
16 H								
STANLY-BOSTITCH								
Hobby 8, Pro 8			6-8					16
Pro 14					6-14			
ST 10			6-10					
ST 14			6-14					16
T 200, TR 100 M2					6-14			
TGD, TGA						6-12		
TR 100					6-14			
TR 200					6-14			16
TR 45			6-10					
TR 250					6-14			12-16
TR 150 HL, TR 151 Y					6-14			
TR 150 L			6-14					12-16
TR 151 YL			6-14					
Hammertacker					6-10			

Fastenings for hand and electronic tackers

		Staples						Brads
kwb-Type		052	053	055	057	058	059	055
Part-No.		352-	353- 053-	355-1 055-5	357-	358- 058-	359-	355-7 055-7
 ↓ mm		6-14	4-20	12-30	6-18	8	6-14	12-30
Manufacturer / machine model								
STANLY-BOSTITCH								
PHT 150					6-10			
SWINGLINE								
90						4-8		
101						6-8		
813, 913						6-12		
800X, 1000, Klammermatic								
Modell 900, 10060, 34201								
Powermatic, Typ 800								
Wammer II								19-25
Wammer 2001, Nagelmatic								25
WOLFCRAFT								
tacocraft 4			6-8					
tacocraft P 10			4-10					
tacocraft P 14 +			6-14					
tacocraft M 10			4-10					
tacocraft M 14 +			6-14					
tacocraft HT 8			4-8					
tacocraft HT 10					6-10			
Taco 8, 7001/02, 7005/06			4-8					
Taco10			4-10					
Taco 14			6-14					16
7003/04, 7007/08			4-14					
7100, 7110			8-18					
Tacomat		6-14						
7160, 7162				18-30				
7165				16-23				
DL 26				12-26				16-25
ET 20			8-18					16

Hot melt glue gun **GLUE GUN FL528 FC**



For quick and secure glueing for handicrafts, repairs, decorating. The universal glue for household, workshop and hobby, pinpoint accuracy glueing of metals, glass, ceramics, marble, wood, leather, textiles, plastics (not PP, PE, Polystyrene). The glue is weather-resistant. Suitable for use indoors and outdoors. AC supply 230 V/ 50Hz, heating up time 3-5 min., operating temperature 195 C, output 14-16 g/min, cable length 140cm, weight 255g

Art.-No.	Contents	Output	Diameter of sticks			Barcode
538320	Hot melt glue gun GLUE GUN FL528 FC, 2 glue sticks 11mm + accessories	20 W (80 W)	11			4 009315 383200

Hot melt glue gun **GLUE GUN FL007**



For quick and secure glueing for handicrafts, repairs, decorating. The universal glue for household, workshop and hobby, pinpoint accuracy glueing of metals, glass, ceramics, marble, wood, leather, textiles, plastics (not PP, PE, Polystyrene). The glue is weather-resistant. Suitable for use indoors and outdoors. AC supply 230 V/ 50Hz, heating up time 3-5 min., operating temperature 195 C, output 8-12 g/min, cable length 140cm, weight 220g

Art.-No.	Contents	Output	Diameter of sticks			Barcode
538211	Hot melt glue gun GLUE GUN FL007, 2 glue sticks 11mm	25 W (70 W)	11			4 009315 382111

Hot melt glue gun **GLUE GUN FL005**



For quick and secure glueing for handicrafts, repairs, decorating. The universal glue for household, workshop and hobby, pinpoint accuracy glueing of metals, glass, ceramics, marble, wood, leather, textiles, plastics (not PP, PE, Polystyrene). The glue is weather-resistant. Suitable for use indoors and outdoors. AC supply 230 V/ 50Hz, heating up time 5-7 min., operating temperature 195 C, output 6-8 g/min, cable length 120cm, weight 135g

Art.-No.	Contents	Output	Diameter of sticks			Barcode
538207	Hot melt glue gun GLUE GUN FL005, 2 glue sticks 7mm	10 W	7			4 009315 382074















Hot melt glue guns

Glue sticks



Glue sticks, transparent, powerful hot melt adhesive for metal, wood, plastics, ceramics, card, leather, foam and textiles, high and long-lasting adhesion.



Art.-No.	Ø mm	Contents	Length			Barcode
538906	7	6 Pcs.	100		6	
539006	11	6 Pcs.	100		6	
539020	11	20pcs.	100		6	
539306	11	6 Pcs.	200		6	
539320	11	20pcs.	200		6	
539350	11	50 pcs.	200		1	

kwb-Info



Work like the professionals – with the wooden „glue sticks“

Now you can assemble shelves and cupboards faster. Simply immerse the pre-glued dowels in water and you can use them right away. Just the right amount of glue will be delivered where it's needed, without messy extru-

sion of surplus glue when valuable furniture components are fitted together.

No need to buy glue, no wastage when half-used tubes of glue get thrown away.

... always the appropriate accessories for your machine!





FIXINGS WOODEN DOWELS

Fixings, wooden dowels



Fixings, wooden dowels

- **DÜBELPROFI**, the patented dowel drilling guide for accurate pre-drilling for dowel joints
- **Professional hinge boring jig** for drilling accurate holes for concealed sprung hinge
- **wooden dowels** for working with wood glue in furniture making

Programme overview



Dübelprofi ★★★★★

A patented dowel drilling guide for accurate 90° pre-drilling on slippery surfaces such as tiles, and dowel joints in wood for furniture making.

Page 332



Professional hinge boring jig ★★★★★

For drilling accurate holes for concealed sprung hinges together with a hinge boring bit or Forstner bit in cabinet making.

Page 332



Wooden dowels and biscuits ★★★★★

For working with wood glue in furniture making.

Page 334



Pinewood plugs ★★★★★

For use as cover caps for screw holes in wood.

Page 335

kwb-Info

Work like a professional cabinet-maker



Tested in the furniture industry

Now you can assemble shelves and cupboards faster. Simply immerse the pre-glued dowels in water and you can use them right away.

Just the right amount of glue will be delivered where it's needed, without messy extrusion of surplus glue when valuable furniture components are fitted together.

No need to buy glue, no wastage when half-used tubes of glue get thrown away.



Pre-glued dowels and biscuits

★★★★★

By simply wetting the dowels they can be used right away to glue the workpieces together, without runs or overspills of glue when the parts are pressed together.

DÜBELPROFI Dowelling Jig



DÜBELPROFI drilling and dowelling guide, with parallel fence and drilling guide, for corner, angle, t- and butt joints, rubber slip protection for slippery and awkward surfaces, for all standard dowels \varnothing 6, 8 and 10 mm, also for use as drilling guide for accurate 90 degree drilling from 3-12mm diameters.

Art.-No.	for drills	for dowels			Barcode
758000	\varnothing 3, 3.3, 4, 4.2, 5, 6, 6.8, 8, 10, 12 mm	\varnothing 6, 8, 10 mm		1	

DÜBELPROFI Dowelling Jig Complete Set





DÜBELPROFI Dowel drilling guide, complete set, with wooden dowels 6,8, and 10mm and CrV wood drills 6,8 and 10mm, with parallel guide and drilling guide, for corner, angle and butt joints, rubber anti-slip protection for slippery and awkward surfaces, for all standard dowels 6,8 and 10mm; also as drill guide for accurate 90 degree drilling between 3-12mm diameters

Art.-No.	Contents			Barcode
758100	1 Dowelling jig 150 Wooden dowels 3 Wood bits		1	

PROFI concealed hinge drilling guide



PROFI hinge boring guide, for making perfectly accurate holes for concealed cupboard hinges, freehand or stationary use, for use with hinge sinker and Forstner bits.

Art.-No.	for dowels			Barcode
759200	\varnothing 26, 35 mm		1	

Fixings

Depth gauge set, 3-piece



Depth stop set, allows variable setting of drilling depth, eg for pre-drilling for dowels, for wood drills 6,8 and 10mm









Art.-No.	for drills			Barcode
530300	ø 6, 8, 10 mm		10	



Marking points



Marking points, for use with wooden dowels







Art.-No.	Ø mm	Contents			Barcode
530206	6	4		10	
530208	8	4		10	
530210	10	4		10	



Drilling and dowelling set



Drilling and dowelling set, CrV wood drill bits, beechwood dowels, marking points, drilling depth stop, glue, for all furniture making.

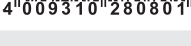







Art.-No.	Contents			Barcode
028060	1 Wood drill bit CV (6mm), 25 wooden dowels (6mm), 4 marking points (6mm), 1 depth stop ring, 1 tube wood glue		10	
028080	1 Wood drill bit CV (8mm), 25 wooden dowels (8mm), 4 marking points (8mm), 1 depth stop ring, 1 tube wood glue		10	
028100	1 Wood drill bit CV (10mm), 25 wooden dowels (10mm), 4 marking points (10mm), 1 depth stop ring, 1 tube wood glue		10	



Pre-glued wooden dowels









Now you can put shelves and cupboards together faster. Simply soak the pre-glued wooden dowels briefly in water and really soon they're ready for use. Sufficient wood glue will get into the joint, no overruns of glue when you press the pieces together to spoil quality woodworking. No need to buy glue, no wastage of dried-up partly used tubes of glue.





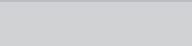

Art.-No.	Ø mm	Contents	Length			Barcode
028260	6	140	30		8	
028280	8	100	40		8	
028300	10	60	40		10	

Wooden dowels

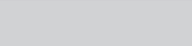

Wooden dowels, beechwood, ribbed, chamfered, for all joinery

Art.-No.	Ø mm	Contents	Length			Barcode
Display card, compact pack						
028160	6	50	30		10	
028180	8	40	40		10	
028200	10	30	40		10	









Art.-No.	Ø mm	Contents	Length			Barcode
Display wallet, large pack						
028560	6	200	30		10	
028580	8	150	40		10	
028600	10	120	40		10	



Pre-glued wooden biscuits



Now you can put shelves and cupboards together faster. Simply soak the pre-glued wooden biscuits briefly in water and really soon they're ready for use. Sufficient wood glue will get into the joint, no overruns of glue when you press the pieces together to spoil quality woodworking. No need to buy glue, no wastage of dried-up partly used tubes of glue.

Art.-No.	Contents	Length	Number	Groove				Barcode
029130	50	55	0	8 mm	4			
029140	50	60	10	10 mm	4			
029150	40	65	20	12 mm	4			







Dowels

Wooden biscuits



Wooden biscuits, beechwood, 4mm thick, for all furniture joints and standard board thicknesses

















Art.-No.	Contents	Length	Number	Groove				Barcode
029100	50	15	0	8 mm	4			
029110	50	19	10	10 mm	4			
029120	50	23	20	12 mm	4			

Wooden plugs



Pinewood plugs, cross-grained, for hiding damage or knots, and as cover caps for screws, to improve the fire resistance in wooden structures.

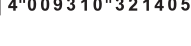

Art.-No.	Ø mm	Contents				Barcode
032115	15	50	10		4	
032120	20	40	10		4	
032125	25	20	10		4	
032130	30	10	10		4	
032135	35	10	10		4	
032140	40	8	10		4	

... always the appropriate accessories for your machine!





ANGLE GRINDER ACCESSORIES

Cutting and grinding discs
Diamond cutting discs
Wire brushes

Cutting discs



For use with all popular angle grinders

- cutting discs, grinding discs, flap discs, polycarbide cleaning discs, fibre-backed sanding discs
- diamond cutting discs

Programmübersicht



CUT-FIX® Cutting discs, ★★★★★ extra thin

Extra thin cutting discs for cutting metals, steel and stainless steel, with long working life.

Page 340



CUT-FIX® Cutting discs ★★★★★

High performance cutting discs for long-term professional use on metal and stone.

Page 341



AGGRESSO-FLEX® ★★★★★ Fibre-backed sanding discs

For heavy-duty sanding and cleaning in steel and metal construction, for derusting, removing paint, scale and varnish, cleaning welding marks.



Page 343 - 344



AGGRESSO-FLEX® ★★★★★ Diamond cutting discs GOLD-Line

Continuous rim, turbo pattern, ideal for granite, concrete, block pavers, roof tiles, all natural and reconstituted stone, hard-fired tiles.



Page 345



AGGRESSO-FLEX® ★★★★★ Diamond cutting discs BLACK-Line

Laser welded, segmented rim, ideal for granite, concrete blocks, pavers, all natural and reconstituted stone.



Page 345



AGGRESSO-FLEX® ★★★★★ Diamond cutting discs WHITE-Line

Continuous rim, for tiles, ceramics, travertin, marble.

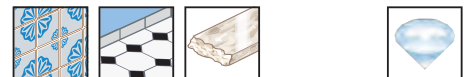

Page 345

Cutting discs, wire brushes



CUT-FIX® Cutting discs **RED-Line** ★★★★★

Continuous rim, turbo pattern, ideal for marble, hollow blocks, roof tiles, ceramic materials, tiles.

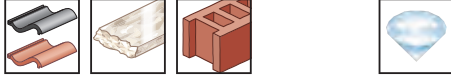

Page 346



CUT-FIX® Cutting discs **GREEN-Line** ★★★★★

Laser welded, segmented edge, ideal for bricks, blocks and paving slabs.



Page 346



AGGRESSO-FLEX® **Extra thin diamond cutting discs** ★★★★★

Extra thin, continuous rim, Turbo edge, ideal for porcelain, tiles and ceramics.



Page 346



AGGRESSO-FLEX® **Diamond face grinding cup** ★★★★★

Laser welded, single row of diamond segments, for heavy duty cleaning and surface grinding, ideal for concrete, screed, render, mortar and natural stone.



Page 347

Brushes



For use with all popular angle grinders

- Wheel, cup and cranked brushes
- HSS steel twist knot wire
- for rust removal and stripping surface coatings
- for descaling and surface levelling
- suitable for metal and stone



AGGRESSO-FLEX® **Cup brushes** ★★★★★

With crimped and twist knot HSS steel wire, for heavy-duty cleaning and for removal of paint, rust, slag and scale from medium to heavy surfaces

Page 348



AGGRESSO-FLEX® **Wheel brushes** ★★★★★

With coarse twist knot HSS steel wire, for heavy-duty cleaning, especially for areas with difficult access, surface levelling, rust removal, scale removal, slag removal, stripping of paint and floor coverings

Page 349

CUT-FIX[®] Cutting discs, extra thin, for metal



Cutting discs, extra thin, for metal, optimal performance with less effort and longer life, especially suitable for thin sheet metal, steel and stainless steel tubes, for all standard angle grinders with peripheral disc speed of 80 m/s.

Art.-No.	mm	Ø x height	Disc shape			Barcode
711911	22	115 x 1,0	---		1	4 0093 17 119 111
711912	22	125 x 1,0	---		1	4 0093 17 119 128
711928	22	180 x 1,4	---		1	4 0093 17 119 289
711933	22	230 x 1,8	---		1	4 0093 17 119 333

CUT-FIX[®] Cutting discs, extra thin, for metal, bargain pack



Cutting discs, extra thin, for metal, optimal performance with less effort and longer life, especially suitable for thin sheet metal, steel and stainless steel tubes, for all standard angle grinders with peripheral disc speed of 80 m/s.

Art.-No.	mm	Ø x height	Contents	Disc shape			Barcode
711921	22	115 x 1,2	10	---		1	4 0093 17 119 210
711922	22	125 x 1,2	10	---		1	4 0093 17 119 227
711929	22	180 x 1,6	5	---		1	4 0093 17 119 296
711934	22	230 x 2,0	5	---		1	4 0093 17 119 340

kwb-Info

A safe job

It's always a good idea to wear protective gloves when your hands could possibly be injured, for example in building work with sharp-edged objects etc. For all types of work, a safe grip and wearer comfort are the prime requirements for the correct type of glove.

You can find further information in our kwb **Personal Protection leaflet**, or on the Internet at www.kwb.eu



Cutting discs

CUT-FIX® Cutting discs for metal



Cutting discs for metal, BF bonding, aluminium oxide abrasive, high quality discs for long-term professional use, for all standard angle grinders with peripheral disc speed of 80 m/s.

Art.-No.	mm	Ø x height	Disc shape			Barcode
791050	16	100 x 3,0	~		25	4 009317 910503
791150	22	115 x 3,0	~		25	4 006317 911150
791250	22	125 x 3,0	~		25	4 009317 912507
791750	22	178 x 3,0	~		25	4 009317 917502
791950	22	230 x 3,0	~		25	4 009317 919506
791970	22	230 x 3,0	~		25	4 009317 919704



CUT-FIX® Cutting discs for stone



Cutting discs for stone, BF bonding, silicon carbide abrasive, high quality discs for long-term professional use, for all standard angle grinders with peripheral disc speed of 80 m/s.

Art.-No.	mm	Ø x height	Disc shape			Barcode
792050	16	100 x 3,0	~		25	4 009317 920502
792150	22	115 x 3,0	~		25	4 009317 921509
792250	22	125 x 3,0	~		25	4 009317 922506
792750	22	178 x 3,0	~		25	4 009317 927501
792950	22	230 x 3,0	~		25	4 009317 929505
792970	22	230 x 3,0	~		25	4 009317 929703



CUT-FIX® Grinding discs, for metal



Grinding discs for metal, BF bonding, aluminium oxide abrasive, high quality discs for long-term professional use, for all standard angle grinders with peripheral disc speed of 80 m/s.







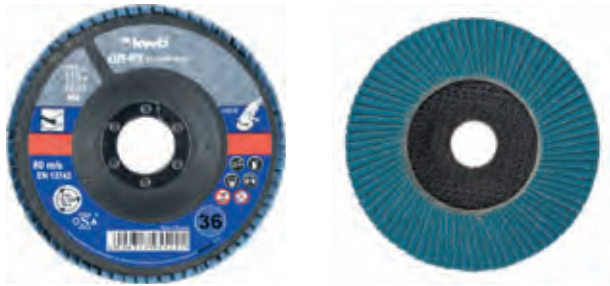

Art.-No.	mm	Ø x height	Disc shape			Barcode
793165	22	115 x 6,0	~		10	4 009317 931652
793265	22	125 x 6,0	~		10	4 009317 932659
793765	22	178 x 6,0	~		10	4 009317 937654
793965	22	230 x 6,0	~		10	4 009317 939658



CUT-FIX® Abrasive flap discs for metal





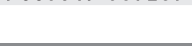





Abrasive flap discs for metal, zirconium abrasive coated, large number of leaves for optimal grinding performance, for long-term professional use, for all standard angle grinders with peripheral disc speed of 80 m/s.

Art.-No.	Ø x shank Ø	Grit	max. Rpm			Barcode
795522	115 x 22	36	13.300		10	
795524	115 x 22	40	13.300		10	
795526	115 x 22	60	13.300		10	
795528	115 x 22	80	13.300		10	
795724	125 x 22	40	12.200		10	
795726	125 x 22	60	12.200		10	
795728	125 x 22	80	12.200		10	

Polycarbide cleaning wheels



Polycarbide cleaning discs, nylon backing, bonded to silicon carbide abrasive, working width 13mm, for precise working up to edges with the edge or the face of the disc, flexible, for sanding and cleaning of steel, sheet metal, wood, plastics and stone, for all common angle grinders with peripheral disc speed of 80 m/s.

Art.-No.	Ø x shank Ø	max. Rpm			Barcode
display packed					
479211	115 x 22	11.000		1	
479311	125 x 22	9.800		1	
Art.-No.	Contents			Barcode	
economy pack					
479292	20 discs Ø 115 x 22			Z20	
479392	20 discs Ø 125 x 22			Z20	











Angle grinder accessories







CUT-FIX® Fibre backed discs, for metal

















Fibre backed sanding discs, for metal, vulcanised backing, aluminium oxide abrasive coated, phenolic resin bonded, for heavy duty sanding and cleaning operations, for steel and metal, for removing rust, paint, scale and varnish, cleaning welding seams, for all commonly used angle grinders with peripheral disc speed of 80 m/s.



Art.-No.	Ø x shank Ø	Contents	Grit			Barcode
display sleeve						
714104	115 x 22	5	40		10	
714108	115 x 22	5	80		10	
714110	115 x 22	5	100		10	
714112	115 x 22	5	120		10	

Art.-No.	Ø x shank Ø	Grit			Barcode
bulk					
714122	115 x 22	24		10	
714124	115 x 22	40		20	
714126	115 x 22	60		20	
714128	115 x 22	80		20	
714130	115 x 22	100		20	

Art.-No.	Ø x shank Ø	Grit			Barcode
bulk					
714222	125 x 22	24		10	
714224	125 x 22	40		20	
714226	125 x 22	60		20	
714228	125 x 22	80		20	
714230	125 x 22	100		20	











Art.-No.	Ø x shank Ø	Grit			Barcode
bulk					
714322	178 x 22	24		10	
714324	178 x 22	40		20	
714326	178 x 22	60		20	
714328	178 x 22	80		20	
714330	178 x 22	100		20	
714332	178 x 22	120		20	



CUT-FIX[®] Fibre backed discs, for metal









Fibre backed sanding discs, for metal, vulcanised backing, aluminium oxide abrasive coated, phenolic resin bonded, for heavy duty sanding and cleaning operations, for steel and metal, for removing rust, paint, scale and varnish, cleaning welding seams, for all commonly used angle grinders with peripheral disc speed of 80 m/s.

Art.-No.	Ø x shank Ø	Contents	Grit			Barcode
Trade bargain pack						
715824	115 x 22	10	24		5	
715840	115 x 22	10	40		5	
715860	115 x 22	10	60		10	
715880	115 x 22	10	80		10	

Backing pads for angle grinders



Backing pad, flexible, with flange nut, dished, for use with fibre-backed sanding discs on all standard angle grinders.

Art.-No.	Ø mm	Thread			Barcode
718111	115	M14		5	
718112	125	M14		5	

kwb-Info

A safe job

Invariably when working with angle grinders there will be sharp-edged particles and dust, which can get in your eyes. We must therefore protect this most important of sensory organs. That's why kwb have put together a high quality programme of protective eyewear, also suitable for spectacle wearers.

You can find further information on the Internet at www.kwb.eu.











Diamond cutting discs

AGGRESSO-FLEX[®] Gold-Line diamond cutting discs



Gold-Line diamond cutting discs, continuous rim, turbo pattern, 10mm high segment, for high cutting performance in long-term professional use, for granite, concrete, pavers, clay and concrete roof tiles, all natural and reconstituted stone, hard-fired tiles, for all stand-ard angle grinders with peripheral disc speed of 80 m/s.











Art.-No.	∅ x shank ∅	 x  mm			Barcode
722540	125 x 22	7,0 x 2,3		1	
722840	230 x 22	7,0 x 2,8		1	



AGGRESSO-FLEX[®] Black-Line diamond cutting discs



Black-Line diamond cutting discs, segmented rim, laser welded segments 10mm deep, for high cutting performance in trade use, for granite, concrete blocks, hard concrete, all natural and artificial stone, for all standard angle grinders with peripheral disc speed of 80 m/s.













Art.-No.	∅ x shank ∅	 x  mm			Barcode
723140	115 x 22	7,0 x 1,9		1	
723540	125 x 22	7,0 x 1,9		1	
723840	230 x 22	7,0 x 2,4		1	



AGGRESSO-FLEX[®] White-Line diamond cutting discs



White-Line diamond cutting discs, continuous rim, turbo pattern, 5mm segment height, for high cutting performance in long-term professional use, for tiles, ceramics, travertin, marble, for all standard angle grinders with peripheral disc speed of 80 m/s.

Art.-No.	∅ x shank ∅	 x  mm			Barcode
725140	115 x 22	5,0 x 1,8		1	
725240	125 x 22	5,0 x 1,9		1	
725750	178 x 25,4/22	5,0 x 2,2		1	
725840	230 x 22	5,0 x 2,5		1	



CUT-FIX[®] Red-Line diamond cutting discs



Red-Line diamond cutting discs, continuous rim, turbo pattern, 7mm high segments, for marble, hollow concrete blocks, concrete roof tiles, ceramics, tiles, for all standard angle grinders with peripheral disc speed of 80 m/s.

Art.-No.	Ø x shank Ø	mm			Barcode
797140	115 x 22	7,0 x 2,1		1	4 009317 971405
797540	125 x 22	7,0 x 2,3		1	4 009317 975403
797840	230 x 22	7,0 x 2,8		1	4 009317 978404

CUT-FIX[®] Green-Line diamond cutting discs



Green-Line diamond cutting discs, segmented edge, laser welded, segment height 7mm, for high cutting performance, for brick, concrete, pavers, for all standard angle grinders with peripheral disc speed of 80 m/s.

Art.-No.	Ø x shank Ø	mm			Barcode
798140	115 x 22	7,0 x 1,6		1	4 009317 981404
798540	125 x 22	7,0 x 1,9		1	4 009317 985402
798740	178 x 22	7,0 x 2,0		1	4 009317 987406
798840	230 x 22	7,0 x 2,2		1	4 009317 988403

CUT-FIX[®] Tile cutting diamond discs



Diamond cutting discs for tiles, continuous rim, turbo edge, segment height 5mm, for high cutting performance on tiles, travertin, for all commonly used angle grinders with peripheral disc speed of 80 m/s.

Art.-No.	Ø x shank Ø	mm			Barcode
795940	110 x 22	5,0 x 1,2		1	4 009317 959403

AGGRESSO-FLEX[®] extra-thin diamond cutting discs



Extra thin diamond cutting discs, extra thin cutting edge, turbo pattern, thickness 1.2mm, optimal cutting performance, less pressure and longer life, especially good for porcelain, tiles and ceramics, for all standard angle grinders with peripheral disc speed of 80 m/s.

Art.-No.	Ø x shank Ø	mm			Barcode
721140	115 x 22	7,0 x 1,2		1	4 009317 211402
724540	125 x 22	7,0 x 1,2		1	4 009317 245407

Diamond cutting discs

AGGRESSO-FLEX[®] diamond face grinding disc



Diamond face grinding cup, single row of diamond segments, laser welded for high performance grinding and cleaning operations for professional use, for cleaning and grinding of concrete, screed, render, mortar and natural stone, for all commonly used angle grinders with peripheral disc speed of 80 m/s.







Art.-No.	Ø x shank Ø	 x  mm			Barcode
726240	115 x 22	6		1	



Grinding Wheels, aluminium oxide



Grinding wheels, aluminium oxide, fine grit (60G), straight edge, for universal grinding of steel tools, especially for fine grinding of hardened and unhardened steel, eg twist drills, screwdrivers, cold chisels, turning tools, wood chisels, wood carving tools and for welding marks, for all standard double-ended bench grinders, supplied with reducing bushes for universal fitting.











Art.-No.	Ø x height	Grit			Barcode
display box					
507220	125 x 20	60 N		1	
507520	150 x 20	60 N		1	



Grinding Wheels, silicon carbide (green grit)



Grinding wheels, silicon carbide (green grit 80 JOT), straight edge and extra hard, suitable for fine grinding of tungsten and tungsten carbide tipped tools, castings, aluminium, all non-ferrous metals, glass, ceramics and stone, for all standard double-ended bench grinders, supplied with reducing bushes for universal fitting.



Art.-No.	 mm	Ø x height	Grit	Bushing			Barcode
display packed							
509220	20	125 x 20	80 JOT	X0		1	
509520	32	150 x 20	80 JOT	X1		1	
509720	32	175 x 25	80 JOT	X1			
509820	32	200 x 25	80 JOT	X1			



Grinding wheel dresser



Grinding wheel dresser, plastic handle, with 9 hardened blades, 18mm wide, 30mm diameter, for cleaning, sharpening and levelling grinding wheels. The blades align the abrasive on the wheel surface in just the right pattern for smooth running and optimal grinding efficiency.

Art.-No.	Ø mm	Length			Barcode
506900	27	105		1	



AGGRESSO-FLEX[®] cup brush, steel wire, Ø 0,35 mm, twist knot



Cup brush, HSS steel wire, twist knot, for derusting, removal of surface coatings, paint, heavy rust and floor coverings, cleaning of shuttering and facades, descaling, deburring, for metal and stone, for working on fairly large areas.

Art.-No.	mm	Wire Ø mm	Ø mm			Barcode
display box						
719106	M 14	0,35	60		2	4 009317 191063
719110	M 14	0,35	100		1	4 009317 191100



Art.-No.	mm	Wire Ø mm	Ø mm			Barcode
bulk in dump bin						
719136	M 14	0,35	60		Z15	4 009317 191360
719126	M 14	0,35	100		Z8	4 009317 191261

AGGRESSO-FLEX[®] cup brush, steel wire Ø 0.5mm twist knot



Cup brush, HSS steel wire, twist knot, for derusting, removal of surface coatings, paint, heavy rust and floor coverings, cleaning of shuttering and facades, descaling, deburring, for metal and stone, for working on fairly large areas.

Art.-No.	mm	Wire Ø mm	Ø mm			Barcode
display box						
719206	M 14	0,5	66		2	4 009317 192060
719210	M 14	0,5	100		1	4 009317 192107



Art.-No.	mm	Wire Ø mm	Ø mm			Barcode
bulk in dump bin						
719236	M 14	0,5	66		Z12	4 009317 192367
719226	M 14	0,5	100		Z6	4 009317 192268

AGGRESSO-FLEX[®] Cranked wheel brush, steel wire, twist knot



Cranked brush, HSS steel wire, twist knot, crooked, for derusting, removal of surface coatings, paint, heavy rust and floor coverings, removing welding marks, descaling, deburring, for metal and stone, for working on narrow edges, frames, gratings and difficult-to-reach areas.

Art.-No.	mm	Wire Ø mm	Ø mm			Barcode
display box						
719330	M 14	0,5	100		2	4 009317 193302

Wire brushes

AGGRESSO-FLEX® Cranked wheel brush, steel wire, twist knot



Art.-No.	mm	Wire Ø mm	Ø mm			Barcode
bulk in dump bin						
719336	M 14	0,5	100		Z8	



AGGRESSO-FLEX® Wheel brush, steel wire, M14, twist knot



Wheel brush, HSS steel wire, twist knot, for derusting, removal of surface coatings, paint, heavy rust and floor coverings, removing welding marks, descaling, deburring and removing of welding marks, for metal and stone, for working on narrow edges, frames and gratings.

Art.-No.	mm	Wire Ø mm	Ø mm			Barcode
display box						
719730	M 14	0,5	115		2	

Art.-No.	mm	Wire Ø mm	Ø mm			Barcode
bulk in dump bin						
719736	M 14	0,5	115		Z8	



AGGRESSO-FLEX® Wheel brush, steel wire, twist knot



Wheel brush, HSS steel wire, twist knot, for derusting, removal of surface coatings, paint, heavy rust and floor coverings, removing welding marks, descaling, deburring and removing of welding marks, for metal and stone, for working on narrow edges, frames and gratings.

Art.-No.	mm	Wire Ø mm	Ø mm			Barcode
Display carton						
719530	22	0,5	115		2	

Art.-No.	mm	Wire Ø mm	Ø mm			Barcode
bulk in dump bin						
719536	22	0,5	115		Z10	



AGGRESSO-FLEX[®] pin spanners



Pin spanner to DIN 3116, for tightening and loosening flanges on market-leading angle grinders

Art.-No.	Shape	Bore ←mm→ x Ø			Barcode
718210	Straight	30 x 4		2	
718310	Straight	35 x 5		2	
718610	Cranked	35 x 5		2	

AGGRESSO-FLEX[®] pin spanner, with flange nut



Pin spanner to DIN 3116, with flange nut, for tightening and loosening flanges on common, market-leading angle grinders

Art.-No.	Shape	Bore ←mm→ x Ø			Barcode
718500	Straight	35 x 5		1	

AGGRESSO-FLEX[®] Flange Nut, top hat



Flange nut, top hat, for securing fibre-backed sanding discs to backing pads on angle grinders.

Art.-No.	Thread	Bore ←mm→ x Ø			Barcode
718320	M 14	35 x 5,8 + 30 x 4,8		2	

AGGRESSO-FLEX[®] Flange nut, flat

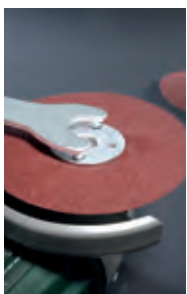

Flange nut, flat, for securing cutting and grinding discs and wire brushes to angle grinders.

Art.-No.	Thread	Bore ←mm→ x Ø			Barcode
717600	M 14	35 x 5,8 + 30 x 4,8		5	

AGGRESSO-FLEX® flat open-end spanner



Open end spanner, flat, for angle grinders

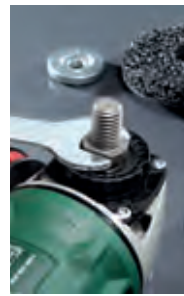

Art.-No.	Length			Barcode
717500	17		5	 4 009317 175001



Angle grinder cut-off stand



Angle grinder cut-off stand, side guard for cutting disc, return spring, heavy duty with solid base plate, clamping device for workpiece, suitable for all standard small angle grinders.

Art.-No.	for			Barcode
778200	Angle grinder 115mm		1	 4 009317 782001



90° Angle screwdriving and drilling attachment	78
360° Angle drilling attachment	104

A

Abrasive belts	189, 192
Abrasive discs	162, 163, 164, 165, 166
Abrasive paper discs	162
Abrasive paper discs bargain pack	162
Abrasive rolls	156
Abrasives detail sanders	170, 171, 172, 173, 174
abrasive sheets	157, 158, 159
Abrasive sheets	157, 180, 181, 182, 185
Accessory set for Mini-Drills	109
Adaptor Set for sockets	91
Adaptor Set for Sockets	91
AGGRESSO-FLEX® Backing pads	344
AGGRESSO-FLEX® Bevelled brushes	348
AGGRESSO-FLEX® Cup brushes	348
AGGRESSO-FLEX® Diamond cutting discs	345
AGGRESSO-FLEX® Diamond extra-thin cutting discs	346
AGGRESSO-FLEX® Diamond face grinding disc	347
AGGRESSO-FLEX® Flange nut	350
AGGRESSO-FLEX® open-end spanner	351
AGGRESSO-FLEX® Pin spanner	350
AGGRESSO-FLEX® Pin spanners	350
AGGRESSO-FLEX® Wheel brushes	349
Angle grinder cut-off stand	351
Angle screwdriver attachment	78
Arbor for holesaws	134
Auger bits	66

B

Backing pad	242
Backing pads	162
Backing pads AGGRESSO-FLEX®	344
Bargain pack abrasive paper discs	162
Bargain pack sandpaper	157, 158, 159
beading cutters	209, 210
Beam drill bits	64
bevel and trim bit	208
Bevelled brushes AGGRESSO-FLEX®	348
Bi-metal universal plunge cutting saw blade	239
Bit and socket set STANDARD	93
Bit boxes	80, 82, 83, 85, 86, 89
Bit dispenser STANDARD	93
Bit holder	76, 77
Bit Set	92
Bit sets	92
Blue Emery Cloth Metal & Steel	158
Brads for tackers	318
brushes	144
Brushes	144, 145, 146, 147, 148, 149, 150
Buffing Wheels	200
Burrs	107, 108
Bürsten	

C

Car body reamer	112
Ceramic grinding wheels	347
chamfering bit	208
channelling chisel	40
Channelling chisel	34
Chisel SDS max	32, 33, 34
Chisel SDS Plus	39, 40
Chuck keys	104
Chucks	102, 103
Circle cutter	56
Cleaning brushes	144
COBALT HSS CO twist drills	10, 11, 12, 13
Combination flap wheel	198
Combi-Pump P60	118
COMPACTA Pump P57	118
Concrete and masonry drill bits ROCKER®	42, 43
Concrete and masonry drill set ROCKER®	43, 44

Concrete and masonry drill set SUPER ROCKER®	45
Concrete and masonry drills SUPER ROCKER®	44
Concrete drills	42
Conecut Drills HSS	112
core box bits	206, 207
Core drills	128
Countersinks	110, 111
Countersink set	110
CROSS-TIP hammer drill bits, Hammer drill bits CROSS-TIP	41
CrV plunge cutting saw blade	239
CrV plunge-cutting saw blade	239
Cup brushes	146, 149
Cup brushes AGGRESSO-FLEX®	348
Cup brushes, nylon	150
CUT-FIX® cutting discs	340, 341
CUT-FIX® Cutting discs, metalworking	341
CUT-FIX® Diamond cutting discs	346
CUT-FIX® Fibre sanding discs	343, 344
CUT-FIX® flap disc	342
CUT-FIX® Grinding discs	341
CUT-FIX® Red-Line diamond cutting discs	346
cutting discs	346
Cutting discs	345, 346
Cutting discs CUT-FIX®	340, 341

D

Depth gauge set	333
Detail sander discs QUICK-STICK	170, 171, 172, 173, 174
Diamond coated screwdriver bits	79
Diamond cutting discs AGGRESSO-FLEX®	345
Diamond cutting discs CUT-FIX®	346
Diamond extra-thin cutting discs AGGRESSO-FLEX®	346
Diamond face grinding disc	347
Diamond holesaws	132, 133
Diamond reciprocating saw blades for tiles and ceramics	237
Diamond saw blade	240
Double ended bit set	92
Dovetail bit	207
Drill bits for hard tiles	54
Drill grinding attachment	27
Drilling and dowelling set	333
Drilling and milling guide	114
Drilling guide	133
Drill mounting bracket	114
Drill stands	114
DÜBELPROFI Dowelling and drilling guide	332
DÜBELPROFI Dowelling and drilling guide, complete set	332
Dust catcher	48

E

EASY CUT jigsaw blades	224, 229, 230
EASY CUT multi-material drill bits	52, 53
EASY CUT multi-material hammer drill bits	52
EASY CUT reciprocating saw blades	233, 237
EASY CUT reciprocating saw blades, metal cutting	236
ECONOMY Bit Set	92
ECONOMY double ended bit set	92
Electronic tackler TACKERTRONIX®	314
engraving bit	209
Expanding wood bit	70
Extra-thin cutting discs	346

F

Face grinding disc AGGRESSO-FLEX®	347
FCE hardwood drill bits	60
Felt polishing pad QUICK-STICK	199
Felt Polishing Wheel	199
Fibre sanding discs CUT-FIX®	343, 344
Flange nut AGGRESSO-FLEX®	350
Flap disc CUT-FIX®	342
Flap wheels	198
Flap Wheels	198
Flat chisel	33, 39
Flat wood bit extension	70

Flat wood bit set	70	Jigsaw blade set	228, 230, 232
Flat wood bits PROFI	69	Jigsaw blades for laminates	227
Flexible shaft	114	Jigsaw blades for wood, cruciform fitting	225
Flooring and installation kit	242	K	
flush trim bit	209	Keyless chucks	102, 103
flute cutters	206	Key type chucks	102, 103
Flute cutters	207	Knife and scissor sharpener	117
Folding roller trestle	114	L	
Forstner wood bits	68	LINE MASTER	215, 216, 217, 218, 219, 220
framework drills	64, 65	LINE MASTER angle fence	215
Framework drills for wood	64, 65	LINE MASTER blade guide	217
G		LINE MASTER circle guide for jigsaws	219
Glass drills	55	LINE MASTER connector	219
Glue sticks	327	LINE MASTER dowel guide adaptor	220
Grinding attachment for drills	27	LINE MASTER fixing clamps	216
Grinding discs CUT-FIX [®]	341	LINE MASTER handle set: LINE MASTER	217
grinding points	115, 116	LINE MASTER machine guid	216
Grinding points	117	LINE MASTER precision rule	215
Grinding wheel dresser	347	LINE MASTER professional set	218
Grinding wheels, ceramic	347	LINE MASTER router guide	220
Grooving chisel	33	LINE MASTER Universal set	218
Grooving cutter	210	Long series masonry drills PROFI	47, 48
H		M	
Hammer drill bit set	38	Mandrel	128, 130
Hammer drill bits HB 44 SDS plus	35, 36, 37	Mandrel for holesaws	136
Hammer drill bits HB44 SDS plus	38	Marking Points	333
Hammer drill bits SDS Max	32	Masonry and concrete drill set	46
hammer tackler	314	Masonry drill bits	46
Hammer tacklers	314	Masonry drill bits, 1/4" hexagon shank	45
Hand sander	196	Masonry drill sets	47
Hand sander set	197	Maxi-Pump P63	119
Hand sanding block	196, 197	Milling cutters	108
Handy Bit Box Diamond	80	Milling cutters for wood	108
Handy Bit Box ISO-TEMP	85	Mini-Drill accessory set	109
Handy Bit Box, stainless steel	86	Mini-Pump P61	119
Handy Bit Box STANDARD	89	Mixed drill set	27
Handy Bit Box titanium nitrided	82, 83	Mounted grinding points	115, 116
Hardwood drill bits	60	Mounted grinding point set	116
Hardwood drill bits FCE	60	Multi-material drill bits EASY CUT	52, 53
HB 44 SDS plus hammer drill bits	35, 36, 37, 38	Multi-material hammer drill bits EASY CUT	52
Heavy Duty Mortar Mixers	120	multi-tool accessories	242
Heavy Duty Paint Mixers	120	Multi-tool accessories	239, 240, 241, 242, 243
Heavy Duty Plaster Mixers	121	N	
Hinge boring jig	332	Nylon strimmer line	309
Hinge sinker bits	67	O	
Holesaws	129, 130, 131, 132, 133, 134, 136, 137, 138, 139, 140	OMT Universal adapter	243
Holesaw set	133, 140	Open-end spanner AGGRESSO-FLEX [®]	351
Holesaw set	135	Ovolo bits	208
Hollow core drills	128	P	
Hollow wood rasps	105	Paint Mixers	120
Hook-and-loop backing pads QUICK-STICK	163, 167, 174	Pilot drill	128, 130
Hot melt glue guns	326	Pilot drill for holesaws	135
HSS bi-metal holesaws	131	Pin spanner AGGRESSO-FLEX [®]	350
HSS Bi-metal holesaws	129, 130	Pin spanners AGGRESSO-FLEX [®]	350
HSS Bi-metal holesaw set	131	Planer blades	211
HSS Conecut Drills	112	Plug cutter set	67
HSS plunge-cutting saw blade	240	Plunge-cutting saw blade	239
HSS step drills	112	Plunge cutting saw blade CrV	239
HSS twist drills	22, 23, 24, 25, 26, 27	Plunge-cutting saw blade HSS	240
HSS twist drills, long series	23	Point chisel	32, 39
HSS twist drills, reduced shank	27	Polishing Bonnet	200
HSS twist drills with 1/4" hexagon shank	22	Polishing bonnet QUICK-STICK	200
I		Polishing Compound Set	201
Industrial tackers	315	Polishing set	201
installation drills	64, 65	Polishing sponge QUICK-STICK	199
ISO-TEMP bit box	85	Polycarbide cleaning disc assortment, 20pcs.	194
ISO-TEMP screwdriver bits	84	Polycarbide cleaning discs	194, 342
J		Pre-glued wooden biscuits	334
Jigsaw blades	224, 226, 228, 229, 230, 231, 232	Pre-glued wooden dowels	334
Jigsaw blades diamond, jigsaw blades, diamond jigsaw blades	228	PROFI flat wood bits	69
Jigsaw blades downcut	226	PROFI hammer tackler	314
Jigsaw blades EASY CUT	224, 229, 230		

Profi hand sander	196	Slip-on countersink set	111
PROFI Hinge boring jig.....	332	Slotting Saw	109
PROFI long series masonry drills	47, 48	Socket Set.....	91
PROFI Power Bit Box STANDARD.....	89	Spade chisel.....	33, 39
Profi tackers	315	Stainless steel bit box.....	86
Profi wood rasps.....	105, 106	Stainless steel screwdriver bits	86
Profi wood rasp set	107	STANDARD bit and socket set.....	93
Pumps	118, 119	STANDARD bit box	89
Q		STANDARD bit dispenser	93
Quick-release bit holder	77	STANDARD PROFI Power Bit Box.....	89
QUICK-STICK ball joint backing pad.....	163	STANDARD screwdriver bits.....	87, 90, 93
QUICK-STICK detail sander discs.....	170, 171, 172, 173, 174	Staples for tackers	316, 317, 318
QUICK-STICK Felt polishing pad	199	Steel Wool	195
QUICK-STICK hook-and-loop backing pads.....	163, 167, 174	Step Drills HSS	112
QUICK-STICK polishing bonnet.....	200	Stripping brushes, nylon	150
QUICK-STICK Polishing sponge	199	SUPER ROCKER® Concrete and masonry drill set.....	45
QUICK-STICK sanding discs.....	162, 163, 164, 165, 166	SUPER ROCKER® Hexagon shank concrete and masonry drills.....	44
QUICK-STICK sanding sheets.....	182, 183, 184	T	
QUICK-STICK scouring pad.....	171, 172	tackler brads	318
R		tackers.....	315
Rasps.....	105	Tacker staples	316, 317, 318
reamer	112	TACKERTRONIX® electronic tackler	314
Rebating bit.....	207	TC saw blade.....	240
reciprocating saw blades.....	233, 237	T-grooving cutter (keyhole slotter)	209
Reciprocating saw blades	233, 234, 235, 236, 237, 238	Tight Corner End Brush	147
Reciprocating saw blades EASY CUT	233, 237	Tile lifting chisel.....	40
Reducing bushes for circular saw blades	277	Tile repair kit.....	242
ROCKER® Concrete and masonry drill bits	42, 43	Titanium HSS rotary file	112
ROCKER® Concrete and masonry drill set	43, 44	Titanium HSS twist drills	14, 15
rolls abrasive	156	Titanium nitrided bit box	82, 83
Rotary burrs.....	107, 108	Titanium nitrided screwdriver bits.....	81
Rotary file HSS Titanium	112	Tube and radiator brushes	148
Rotary files	113	Tungsten carbide circle cutter	56
Rounding over bit.....	208	Tungsten carbide planer blades.....	211
Router cutters.....	206, 207, 208, 209, 210	Tungsten carbide rasp	241
Routter cutters.....	206	Tungsten steel holesaws.....	136
S		Twist drills COBALT HSS CO.....	10, 11, 12, 13
Sanding belts.....	189, 192	Twist drills HSS.....	22, 23, 24, 25, 26, 27
Sanding discs QUICK-STICK.....	162, 163, 164, 165, 166	Twist drills SILVER STAR HSS	16, 17, 20, 21
sanding sheets	157, 158, 159	Twist drills Titanium HSS.....	14, 15
Sanding sheets	157, 180, 181, 182, 185	U	
Sanding sheets QUICK-STICK	182, 183, 184	Universal adapter OMT	243
Sanding sponges	193, 194	Universal arbor	201
Sandpaper.....	157, 158, 159	universal brushes.....	144
Sandpaper bargain pack.....	157, 158, 159	Universal kit.....	243
Saw blade diamond.....	240	Universal plunge cutting saw blade bi-metal	239
Saw blades for lightweight blocks	238	W	
Saw blade TC	240	Water feed system	132
Saw Chains for chain saws.....	281	wheel brushes	144
Scouring pad QUICK-STICK.....	171, 172	Wheel brushes.....	145, 146
Scraper	241	Wheel brushes AGGRESSO-FLEX®	349
Screwdriver bits.....	79, 84, 86, 87, 90, 93	Wheel brushes, brass.....	149
Screwdriver bits, diamond coated.....	79	Wheel brushes, nylon.....	150
Screwdriver bits, ISO-TEMP	84	Wheel brushes, stainless steel	149
Screwdriver bits, stainless steel	86	Wire brush sets	148
Screwdriver bits STANDARD	87, 90, 93	Wood contouring brushes	147
Screwdriver bits, Titanium nitrided.....	81	Wood drill bits.....	61, 62, 64
Screw eye/ wingnut screwdriver bit.....	92	Wood drill bit sets	61
SDS max chisel.....	32, 33, 34	Wood drills	63
SDS Max hammer drill bits	32	Wood drill set.....	63
SDS Plus chuck adaptor	104	Wooden biscuits	335
SDS plus hammer drill chisel	39, 40	Wooden biscuits, pre-glued	334
Set of mini grinding points.....	117	Wooden dowels	334
Shaft, flexible.....	114	Wooden dowels, pre-glued	334
Sharpening Stone	117	Wooden plugs.....	335
SILVER STAR HSS twist drills.....	16, 17, 20, 21	Wood rasps	105, 106, 107

kwb qualities

kwb stands for quality.

With the triple-graded quality system from kwb, you can always find the right tool for your particular needs and levels of use.



PROFESSIONAL



The best kwb quality, also suitable for long-term professional use. 5 year guarantee.



HIGH QUALITY



The high grade kwb quality, suitable for professional DIYers.



QUALITY



The everyday good quality from kwb, for DIY use.

Refer to this page for the key to the kwb pictograms and logos

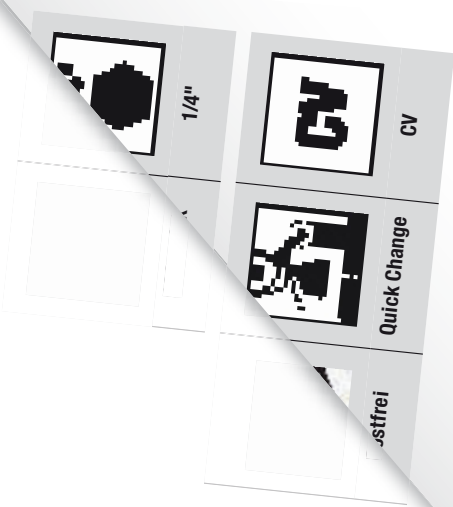

Overview of the kwb pictograms and logos

								
Titanium	Stainless steel	Steel	Iron	Cast iron	Non-ferrous metals	Sheet metal	Profiles	Aluminium
								
Bronze	Plastic	Acrylic	Concrete	Concrete without reinforcement	Stone/masonry	Sand-lime brick	Aerated concrete	Hollow brick
								
Screed	Plaster	Plasterboard	Lightweight construction materials	Hardwood	Softwood	Thick softwood	Firewood	Profiled timber
								
Laminate	Wooden planks for terraces	Formwork	Plywood	Chipboard (coated)	Chipboard	Construction timber	Blockboard	Glass/crystal
								
Porcelain	Ceramics/wall tile	Floor tile	Porcelain stoneware	Marble	Floor clinker	Concrete stone	Exposed aggregate concrete	Granite
								
Roof tiles	Natural stone	Grout	Carpet remnants	Tile glue	Paint			
								
Made in EU	Made in Germany	Cross Tip	Diamond	without impact	SDS max	SDS plus	SDS quick	1/4"
								
Shaft E 6.3	Impaktor	Stronger	Hexagon	Tip 118°	Tip 135°	Rust-proof	Quick Change	CV
								
HM	OSA	TQ 60	Quick-action keyless chuck	Geared chuck				

kwb tools GmbH

Industriestraße 35

D - 28816 Stuhr

Tel.: + 49 (0) 421 8994-0

Fax: + 49 (0) 421 8994-103

welcome@kwb.eu

www.kwb.eu